



All specification subject to change
© 2002-2003 Aerospace Logic Inc.

EGT-100 Operations and Installation Manual

This manual is certified for use with
instrument serial number

ASL000000

Use of this manual with any other
instrument voids all warranties and may
result in damage to the instrument

READ THIS FIRST

Congratulations on the purchase of your EGT-100 Exhaust Gas Temperature Indicator. This instrument is a complex precision instrument manufactured to exceed Airborne Equipment Standards DO-160D, DO-178B and TSO C43c standards. In order for your instrument to function correctly you will need to review the instructions in this brief manual.

This document covers the following instrument models:

- EGT-100-4 4 Cylinder EGT
- EGT-100-4V 4 Cylinder EGT with Voltmeter
- EGT-100-6 6 Cylinder EGT
- EGT-100-6V 6 Cylinder EGT with Voltmeter

Aerospace Logic Inc.

3150 Ridgeway Drive, Unit #43, Mississauga, Ontario, L5L 5R5, CANADA
Tel. (905) 569-3887 | Fax. (416) 352-5854 | Email. sales@aerospacelogic.com
www.aerospacelogic.com

EGT-100 Operations & Installation Manual – Ver. 1.9 – June 5, 2003

1. Introduction

Your EGT-100 Exhaust Gas Temperature Indicator will provide you with years of reliable service and generally outlast the life of your aircraft. The instrument is constructed from the highest quality components and has a design life in excess of 100,000 hours.

It is the most reliable instrument of its kind. Gone are the days of questioning the accuracy or operation of the instrument. No stuck needles, erroneous readings or instruments that keep you guessing as to their operational status.

Every reading you will see displayed on your instrument has been validated at least 256 times before you see it. This all happens in less than a second. When you see the result you know the instrument is functioning correctly as it is monitored by an independent microprocessor just to ensure that it is functioning correctly. In turn the main processor validates the independent monitoring processor. Any failure detected in either processor and your instrument display will be shut down or an error message displayed – depending on the failure status.

2. Display

The main display of the instrument displays a graphical representation of the temperature of the selected cylinder on the bar display, provided the temperature is within the defined limits set by the user. The lower four-digit seven-segment display provides a mathematically computed display of the specific temperature.

The **A M S** switch allows you to select the various functions of the instrument. When the switch is placed in the **A** position the instrument is placed in the **AUTOMATIC** mode. In this mode it will select and display the information for the hottest cylinder.

When in the **M** position the instrument allows **MANUAL** selection of the function of choice. Available functions are: **STEP, 1, 2, 3, 4, 5, 6**, (5 and 6 only available on 6 cylinder models) where the numbers correspond to the cylinder number to be monitored. In the **STEP** mode the instrument will sequentially step through all cylinders.

Moving the **A M S** switch momentarily to the **S** position will allow movement between the manually selectable pages.

Aerospace Logic Inc.

3150 Ridgeway Drive, Unit #43, Mississauga, Ontario, L5L 5R5, CANADA
Tel. (905) 569-3887 | Fax. (416) 352-5854 | Email. sales@aerospacelogic.com
www.aerospacelogic.com

EGT-100 Operations & Installation Manual – Ver. 1.9 – June 5, 2003

3. Installation

Ensure that the thermocouple probes have been installed PRIOR to installing the instrument. **See *Probe Installation for full details (Section 6)***.

The EGT-100 will fit any standard 2 ¼" aircraft mounting hole. Place the instrument in the hole from the rear of the panel and then attach it with the four screws provided. If you need to replace the screws, ensure that the threads do not penetrate the instrument more than ½". Screws that penetrate the instrument further will cause severe damage to the instrument.

WARNING

This instrument is a highly sensitive and accurate instrument, however without proper wiring and connections it is possible to induce temperature reading errors.

Please read and follow all instructions carefully to ensure proper operation.

The instrument has been software calibrated and never needs recalibration provided no wiring modifications are made at installation time.

Now connect the supply and dimmer wiring. These wires may be trimmed to any desired length.

RED	Master switched 14/28V bus (Instrument is internally fused)
BLUE	28V Dimmer control (if required)
WHITE	14V Dimmer control (if required)

NEXT CONNECT THE BLACK WIRE TO A GROUND POINT ON THE ENGINE

BLACK Aircraft supply ground connected on engine ground point.

Wherever possible ensure that connection to the probe ends is made on the cockpit side of the firewall. If this is not possible ensure that the junction between the signal wiring from the instrument and the probe is in the coolest possible location in the engine compartment.

Next connect the probe signal wiring. These wires are the red/yellow twisted pairs. Each cylinder is identified by a color tag on the specific twisted pair.

Do NOT un-twist these cable pairs. They are designed to reduce signal noise.

Do NOT trim the thermocouple probe wires under any circumstances.

Where possible **do NOT** strap the signal wiring to other aircraft wiring.

Trim these wires to length if necessary, but **do not** remove the color code tags.

Aerospace Logic Inc.

3150 Ridgeway Drive, Unit #43, Mississauga, Ontario, L5L 5R5, CANADA
Tel. (905) 569-3887 | Fax. (416) 352-5854 | Email. sales@aerospacelogic.com
www.aerospacelogic.com

EGT-100 Operations & Installation Manual – Ver. 1.9 – June 5, 2003

Thermocouple signal cables are red/yellow twisted pairs. The colors listed refer to the tag color on the wire pair. Green and yellow tags are only on 6 cylinder instruments.

BLACK	Cylinder 1	BLUE	Cylinder 4
RED	Cylinder 2	GREEN	Cylinder 5
WHITE	Cylinder 3	YELLOW	Cylinder 6

If you have purchased a complete instrument and probe kit appropriate connectors for interconnection of the signal wires and probe leads are provided. If you have purchased only the instrument NO connectors are provided as there is no way of determining what type of probes will be used. In this case the installer is to provide the necessary connectors. **WARNING! TSO and STC certifications for this instrument will be void if it is used in conjunction with NON-TSO'd thermocouples! See Specifications for requirements.**

For installation of the complete kit, simply snap the connectors together for the appropriate cylinders, slide the included heat shrink sleeves over the connection and shrink to size. Take care in matching the correct color coded signal pair to the correct cylinder.

Aerospace Logic Inc.

3150 Ridgeway Drive, Unit #43, Mississauga, Ontario, L5L 5R5, CANADA
Tel. (905) 569-3887 | Fax. (416) 352-5854 | Email. sales@aerospacelogic.com
www.aerospacelogic.com

EGT-100 Operations & Installation Manual – Ver. 1.9 – June 5, 2003

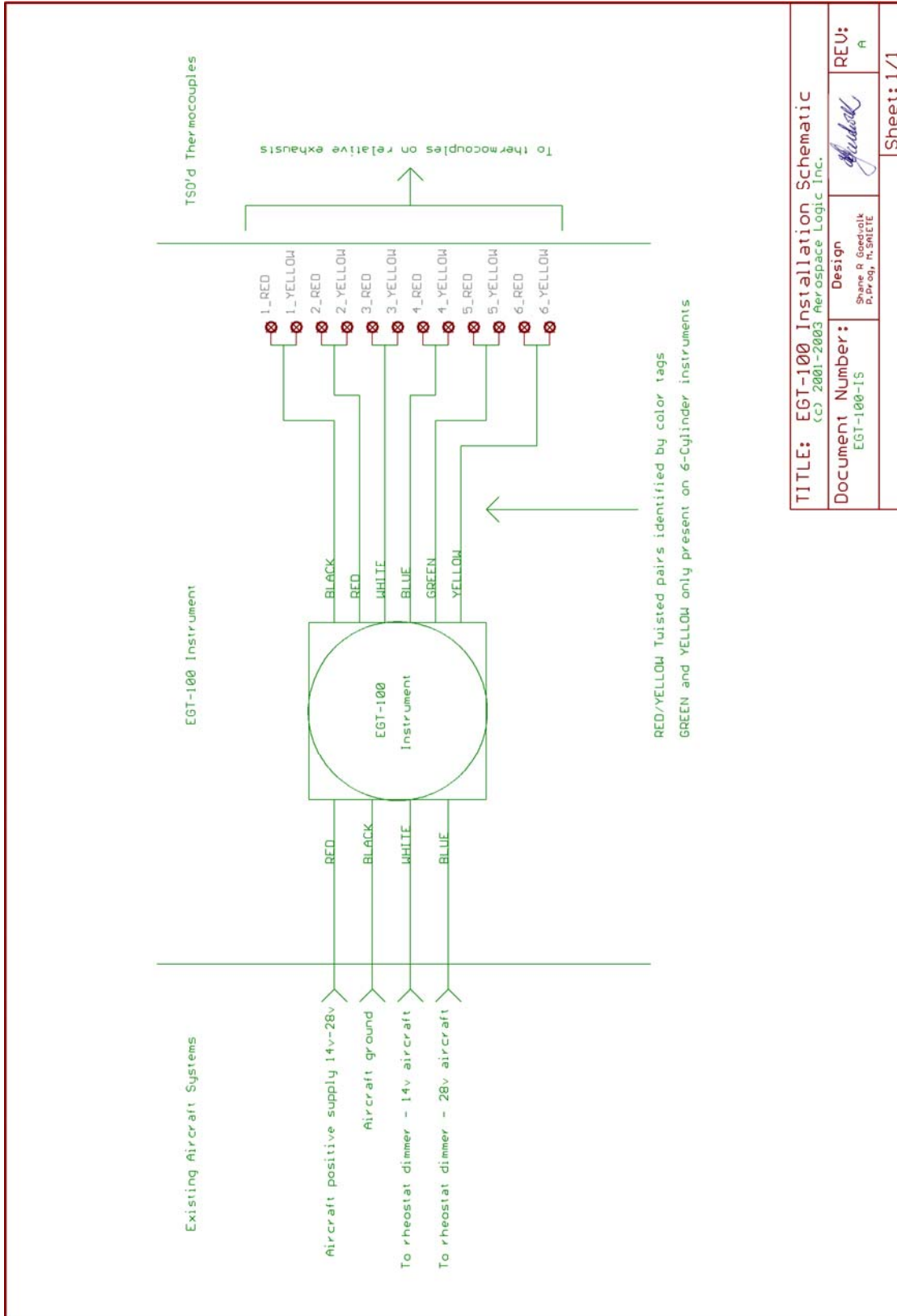

Aerospace Logic Inc.

3150 Ridgeway Drive, Unit #43, Mississauga, Ontario, L5L 5R5, CANADA
Tel. (905) 569-3887 | Fax. (416) 352-5854 | Email. sales@aerospacelogic.com

www.aerospacelogic.com

EGT-100 Operations & Installation Manual – Ver. 1.9 – June 5, 2003

4. SETUP

Once installed your instrument will require setup to match the specific engine parameters as well the user defined preferences.

Instrument setup is only required when a parameter or display configuration is to be changed. With proper planning you should only have to perform this function once in the life of the instrument. All information is stored in the instruments lifetime memory, which will be retained without battery power for up to 100 years.

To enter **SETUP** mode turn off all power to the instrument. Next press and **HOLD** the **A M S** switch in the **S** position and turn on the power to the instrument. Hold the switch in this position until **SEt-** is displayed. At this point release the switch.

NOTE: When in the setup mode the display bar will remain blank. The CYL digit and the four digit display shows the parameter value and type as per the enclosed instructions.

In order to set the manufacturer specified limits for your engine you will require the manufacturer specified high and low limits. Please refer to your engine operator's manual for this information. Most engines will operate between 1300°F and 1600°F.

CyLS (Cylinder Count Selection)

For a 6 cylinder instrument, moving the **A M S** switch to the **A** position and back to the **M** position will allow selection between 4 and 6 cylinder operation.

For a 4 cylinder instrument, no choice of cylinder count is available. Simply move the **A M S** switch once to the **S** position and release. The 4 cylinder configuration will now be saved and the display will move to the next parameter.

Int (Intensity Source Selection)

Moving the **A M S** switch to the **A** position and back to the **M** position will allow selection between **I** (internal intensity control) or **E** (external intensity control).

Select the appropriate intensity source and move the **A M S** switch once to the **S** position and release. The intensity source will now be saved and the display will move to the next parameter.

Aerospace Logic Inc.

3150 Ridgeway Drive, Unit #43, Mississauga, Ontario, L5L 5R5, CANADA
Tel. (905) 569-3887 | Fax. (416) 352-5854 | Email. sales@aerospacelogic.com
www.aerospacelogic.com

EGT-100 Operations & Installation Manual – Ver. 1.9 – June 5, 2003

L (Low Temperature Limit Set)

The low temperature limit should be set to the manufacturers recommended low limit for correct operation. This setting determines the point at which the bar indicator will begin to turn on. Values for this setting can range from 1000° to 1600°F.

Moving the **A M S** switch to the **A** position and holding it there will allow the temperature to increment. Initially the increment will be at a slow rate and then speed up to a faster rate for easy selection. Once the increment is in the fast mode it can be slowed again by moving the **A M S** switch once to the **M** position and then back to the **A** position. Once the maximum (1600°F) has been reached the count will start over at 1000°F.

Once the correct temperature has been reached, by moving between the **A** and **M** positions of the **A M S** switch, move the **A M S** switch once to the **S** position and release. The low limit will now be saved and applied to all cylinders. The display will move to the next parameter.

H (High Temperature Limit Set)

The high temperature limit should be set to the manufacturers recommended high limit for correct operation. This setting determines the point at which all bars on the bar indicator will turn on. Values for this setting can range from the low limit plus 20°F to 1800°F.

Moving the **A M S** switch to the **A** position and holding it there will allow the temperature to increment. Initially the increment will be at a slow rate and then speed up to a faster rate for easy selection. Once the increment is in the fast mode it can be slowed again by moving the **A M S** switch once to the **M** position and then back to the **A** position. Once the maximum (1800°F) has been reached the count will start over at the preset low limit plus 20°F.

Once the correct temperature has been reached, by moving between the **A** and **M** positions of the **A M S** switch, move the **A M S** switch once to the **S** position and release. The high limit will now be saved and applied to all cylinders.

DonE

The display will now show the characters **DonE** and the instrument will restart. At this point you have completed all the setup and configuration of the instrument and it is ready for service.

Aerospace Logic Inc.

3150 Ridgeway Drive, Unit #43, Mississauga, Ontario, L5L 5R5, CANADA
Tel. (905) 569-3887 | Fax. (416) 352-5854 | Email. sales@aerospacelogic.com
www.aerospacelogic.com

EGT-100 Operations & Installation Manual – Ver. 1.9 – June 5, 2003

5. Operation

Once power is applied to the instrument it will display the model number and a **tES**t message with the complete display lit. Immediately following this it will display the temperature information and default to the **STEP** mode.

MANUAL MODE

In the manual mode (**A M S** switch in the **M** position) movement between the different manually selectable functions is achieved by moving the **A M S** switch once to the **S** position and then releasing it. The order of display is:

STEP Sequentially displays each cylinder temperature for 5 seconds.

In the **STEP** mode the instrument will display the **STEP** message for approximately five seconds before starting the step process. Once started it will step through all cylinders. When the last is reached, it will revert back to the first.

- 1 Display temperature information for cylinder 1
- 2 Display temperature information for cylinder 2
- 3 Display temperature information for cylinder 3
- 4 Display temperature information for cylinder 4

For 6 cylinder instruments two additional displays are:

- 5 Display temperature information for cylinder 5
- 6 Display temperature information for cylinder 6

For instruments with the optional voltmeter function:

- v** Displays line voltage present on the instrument supply bus

If the internal intensity option has been selected:

- ^** Increase intensity

Moving the **A M S** switch to the **A** position will increase the brightness of the display. Move the switch back to the **M** position when the desired brightness is reached.

- v** Decrease intensity

To decrease the brightness move the **A M S** switch to the **A** position. Move the switch back to the **M** position when the desired brightness is reached.

Aerospace Logic Inc.

3150 Ridgeway Drive, Unit #43, Mississauga, Ontario, L5L 5R5, CANADA
Tel. (905) 569-3887 | Fax. (416) 352-5854 | Email. sales@aerospacelogic.com
www.aerospacelogic.com

EGT-100 Operations & Installation Manual – Ver. 1.9 – June 5, 2003

If the instrument is left in the intensity mode without any changes for more than eight seconds it will revert to the last selection. We recommend the use of the internal intensity control for the most accurate control of the brightness of the instrument.

AUTOMATIC MODE

Moving the **A M S** switch to the **A** position will place the instrument in the automatic mode.

In this mode it will select and display the temperature for the hottest cylinder. All cylinders are scanned in less than one second and the display updated at the same rate.

This mode of operation is the single most important feature of this instrument and should be used during leaning and normal operations.

Leaning in the automatic mode ensures that no cylinder is overheated during the process.

If the instrument is switched from the automatic mode back to the manual mode it will revert to the last selected manual function.

For complete leaning instructions and limits refer to your engine manufacturers recommended procedures, then select the AUTO mode for a hassle free leaning process.

DISPLAY

The bar display will display a graphic representation of the selected cylinder temperature between the defined low and high limits. Each bar represents 1/10 of the temperature range between the low and high limits.

For temperatures in excess of the high limit the two upper bars (red bars) will blink. Once the temperature cools and is within the limits the blinking will cease. The over temperature blinking does not occur in the STEP mode.

Temperatures below the low limit will only be displayed on the four digit display.

If the temperature is below 200°F the display will read **COLd**. As soon as the temperature exceeds this limit it will be displayed.

Aerospace Logic Inc.

3150 Ridgeway Drive, Unit #43, Mississauga, Ontario, L5L 5R5, CANADA
Tel. (905) 569-3887 | Fax. (416) 352-5854 | Email. sales@aerospacelogic.com
www.aerospacelogic.com

EGT-100 Operations & Installation Manual – Ver. 1.9 – June 5, 2003

6. Probe Installation

NOTE: This section refers primarily to installation of probes supplied as a kit with the specific instrument. For installation using existing or owner supplied probes please see the specific probe manufacturer information.

The instrument will support all grounded and ungrounded probes that meet the requirements listed in the Specification Section.

Thermocouple / Signal Wire Junction

Where possible, plan the installation such that the junction between the thermocouple and signal wire takes place on the cockpit side of the firewall. If this is not possible ensure that the junction is in the coolest possible location in the engine compartment.

Ensure that ALL thermocouple leads are strapped together at the junction point. This will further eliminate the possibility of any ground loop problems.

Connection

Thermocouple leads are marked with red (negative) and yellow (positive) sleeves and match the corresponding red and yellow twisted pair signal wires. Simply snap the corresponding connections together, slide the heat shrink sleeve over the junction and shrink to size when installing the instrument.

For installation of the probe end into the exhaust please see the illustration as below:

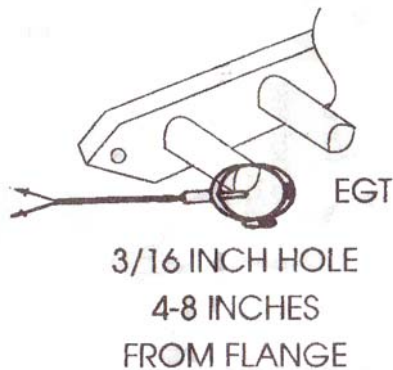

Aerospace Logic Inc.

3150 Ridgeway Drive, Unit #43, Mississauga, Ontario, L5L 5R5, CANADA
Tel. (905) 569-3887 | Fax. (416) 352-5854 | Email. sales@aerospacelogic.com
www.aerospacelogic.com

EGT-100 Operations & Installation Manual – Ver. 1.9 – June 5, 2003

7. EGT-100 Specifications

<p>Dimensions:</p> <ul style="list-style-type: none"> • Fits standard 2.25" mounting hole • 2.45" X 2.45" X 1.6" • 2" viewing area • Weight: 10oz (4 cyl.) / 13oz (6 cyl.) <p>Display</p> <ul style="list-style-type: none"> • Custom design color bar display • Multi-color sunlight visible • InGaAlPGaN LED technology • 100,000 hours operating life • Analog and digital readout of temperatures <p>Maximum Ranges</p> <ul style="list-style-type: none"> • 0°F – 1900°F. Displays 200°F – 1900°F as actual temperature and 0°F – 199°F as "COLD" • Voltmeter: 6.0v to 32v (optional) <p>Accuracy</p> <ul style="list-style-type: none"> • 1% of range per TSO (SAE AS8005 Class IIa instrument classification) • Voltmeter: 1/10 Volt over full operating range <p>Safety</p> <ul style="list-style-type: none"> • Color coded temperature values • Visual high temperature alarms for each cylinder • Dual processor monitoring with one second error shutoff • Internal over temperature shutoff • Floating point mathematical compensation for thermocouple sensor linearity • Minimum 256 times measurement validation before display <p>Operating Temperature</p> <ul style="list-style-type: none"> • -15°C to +55°C • 5°F to 131°F <p>Power Consumption</p> <ul style="list-style-type: none"> • 370mA Max (daytime operation) • 50mA Min (nighttime operation) <p>Display Units</p> <ul style="list-style-type: none"> • °F – temperature • Volts – voltmeter (optional) 	<p>Display Pages/Functions</p> <ul style="list-style-type: none"> • AUTO – automatically select and display hottest cylinder. One second scan rate for 4/6 cylinders • STEP – sequentially step through each cylinder with five second intervals • 1 – 4/6 – manually select and display any cylinder information • High limit alarms (visual) • Integrated voltmeter (optional) • Two brightness selection pages (internal intensity selection) <p>Intensity Control</p> <ul style="list-style-type: none"> • Programmable user option • External using rheostat type dimmer • Internal selection programmable from the front panel • 256 level of brightness <p>Linearity</p> <ul style="list-style-type: none"> • Mathematical compensation over the full operating range <p>Operating Voltage</p> <ul style="list-style-type: none"> • 6V-32V DC <p>Thermocouples Supported</p> <p>ONLY TSO'd thermocouples that possess the following characteristics:</p> <p>Recommended type Westach series 713 EGT probes.</p> <ul style="list-style-type: none"> • Type K with outputs as listed: • 200°F – 2.87mV • 400°F – 7.36mV • 800°F – 16.58mV • 1000°F – 21.31mV • 1200°F – 26.03mV • 1400°F – 30.70mV • 1500°F – 32.90mV • 1600°F – 35.24mV • 1800°F – 39.67mV
 <p>All specification subject to change © 2002-2003 Aerospace Logic Inc.</p>	

Aerospace Logic Inc.

3150 Ridgeway Drive, Unit #43, Mississauga, Ontario, L5L 5R5, CANADA
 Tel. (905) 569-3887 | Fax. (416) 352-5854 | Email. sales@aerospacelogic.com
www.aerospacelogic.com