



Integrated Back-up Battery System

Model: IBBS-12v-4ah

The ***Integrated Back-up Battery System, IBBS***, is an electronic system that combines a Ni-mh battery pack, a charger and switching logic in one convenient package. The IBBS provides an engineered solution to enable an endurance bus for critical loads found in aircraft. It simplifies the wiring and installation of a source of back-up power by integrating all of the key elements into a single enclosure. The ***IBBS*** system provides back-up power to critical electronic loads such as EFIS, GPS, Autopilots and engine monitor systems.

Integral to the IBBS is a nickel metal-hydride battery pack and a matched charging system to ensure the battery is properly charged and maintained. The system also includes switching circuitry to provide a stable source of output power during normal and emergency operations. The IBBS system also provides signals to other equipment such as EFIS systems to communicate the operating state of the back-up bus as well as the state of the battery.

The IBBS system connects to the standard aircraft power bus and provides an output to critical equipment that requires back-up power. Additionally, the IBBS system provides surge and sag protection for connected equipment, allowing operation of critical equipment during engine starting.

The IBBS system is suitable for use with equipment such as Garmin GNS-430/w, GNS-530/w, G3X series of avionics, Grand Rapids Technologies EFIS systems, Advanced Flight Systems EFIS, Dynon EFIS, and MGL EFIS, TruTrak Autopilots and EFIS, Trio Autopilots.

No other uses of the IBBS system are permitted except for those identified in this installation manual.

IBBS must be installed using the current aircraft standards and practices as shown in AC 43.13-2A/1B. The installer/builder is solely responsible for determining the suitability of the installation and use of this product.

Installation Instructions:

1. IMPORTANT NOTE:

Consult the attached wiring diagrams to identify wiring connections similar to your particular installation. Please note, some equipment such as GPS's and EFIS systems may be provided with multiple power inputs. For these installations the output of the IBBS must be connected to their "back-up" power input. It is strongly recommended that the "main" power input of these type devices be provided from the aircraft avionics bus. The "back-up" power source should be provided through the IBBS product. For equipment having a single source of power, the IBBS system may be fed from a bus that remains active during engine starting, such as the master bus or it may be fed from an avionics bus that is switched off during engine starting.

Garmin 430/530(w) GPS systems are available in versions with and without back-up power inputs. Consult the Garmin GPS installation manual to determine which model you are working with, wiring diagrams for connection of each type to the IBBS system are shown at the end of this document.

2. Check that the total connected load (summed value of all three output wires) is less than the following product ratings:

**IBBS-12v-4ah = 6 amps maximum continuous current,
9 amps peak for radio transmissions and transient loads.**

3. Mount the IBBS in a suitable location in the aircraft. Ensure the mounting points and fasteners are suitable for the weight of the product, consult the specifications for details. The IBBS must be mounted inside the aircraft, do not mount the IBBS in the firewall forward area. Do not mount the IBBS unit up under the instrument panel. Select an area that is accessible to allow for future battery servicing. The operating temperature range of the system is -10 C° to 60 C° and the effective charging temperature range is 0 C° to 40 C°. Select an installation location that will comply with these requirements.
4. Connect the aircraft wiring according to the wiring diagrams as shown. The IBBS must be powered through a properly sized circuit breaker or fuse. ENSURE the proper size wire is utilized for the input feed, output supplies and ground connection. The IBBS has two parallel inputs, both of these must be utilized. Connect the two input wires together at the fuse or circuit breaker as shown in the diagrams. The IBBS has three parallel outputs which may be used to power separate pieces of equipment that require back-up power. The three output wires on the IBBS system are internally protected with a single 10 amp polyswitch type PTC. No additional external fusing is required; however use at least 20 awg wire for each of

the three output wires. If only one or two output wires are utilized do not populate the extra output terminals in the connector or securely cap off the unused wires.

5. The Back-up Power Master switch must be utilized in the installation. This switch gives the pilot the ability to turn the back-up battery system off. In some installations this may be the only means to shut down the connected equipment.
6. Complete the installation of the wiring harness and connector prior to attaching the connector to the IBBS product. This is essential to ensure the wires do not inadvertently short together during installation. Remember, the IBBS pack is a back-up source of power and is ready to deliver output power even when the aircraft electrical system is in the off state.
7. When using the IBBS product to provide back-up power to an electronic ignition system it **MUST** be used to back-up one and only one electronic ignition module. Do not use one IBBS to back up both electronic ignition modules in a dual electronic ignition system. Follow wiring diagram for installation with electronic ignition module; note, system connection directly to aircraft battery must be utilized as shown.
8. When using the IBBS product to provide back-up power to an electronic ignition system (CDI) pullable circuit breakers must be used for over current protection as shown on page 16.
9. When using the IBBS product to provide back-up power to an electronic ignition system, connect one and only one CDI module to an IBBS unit. **DO NOT CONNECT** any other loads to the IBBS. It must only be used to back up the CDI unit. Follow the wiring diagram on page 16 exactly.

Product Details and General Information:

Back-up Power Master Switch:

The IBBS has one input switch connection as identified in the wiring diagrams: Back-up Power Master. This switch enables back-up power from the IBBS system to be available on the output wires when power on the normal aircraft bus falls into the range of 10-11 volts.

If the back-up power master switch is enabled and normal aircraft power falls into the range of 10-11 volts, then the internal back-up battery will be connected to the outputs and be utilized to supply back-up power to the connected load.

If the normal aircraft power bus is above 11 volts, then the outputs are energized with normal aircraft power and the back-up battery remains off-line. This operation occurs regardless of the state of the Back-up Power Master switch. This allows for automatic pass through of power during normal operation.

The “Info wire”:

The IBBS includes an “info” wire as shown in the wiring diagrams. The “info” wire may be used in conjunction with other equipment such as EFIS systems or engine monitors to provide information regarding the state of the back-up battery system. When the IBBS is off-line and normal aircraft power is available on the input of the IBBS, the “info” line may be read to determine the internal battery voltage. A nominal battery with a full charge will read between 12 and 15 volts. When the IBBS is on-line providing back-up power, the “info” line is pulled to a logic low level to signal connected equipment that the system is currently running on back-up power.

Alternately, the “info” wire may be connected to a warning lamp to indicate that the main aircraft bus is low and the back-up bus should be switched on. See wiring diagrams for LED warning lamp usage.

The Charging System:

The IBBS automatically maintains its internal battery pack. The internal charging circuit monitors the state of the internal battery and recharges it as necessary when the aircraft is operational. The maximum input current for battery recharging is 3.75 amps. When the aircraft power bus is in the off state, a maintenance current of up to 4 milliamps may be drawn from the aircraft battery to ensure the back-up battery remains charged. The maintenance charge current is drawn from the input wire marked: Aux Battery Trickle Charge. If the internal battery is fully discharged for any reason it may require up to two hours of recharge time with the normal aircraft bus on. NOTE: Do not attempt to recharge the IBBS product by using an external battery charger directly connected to the input of the IBBS. Battery chargers typically provide pulsating voltages that will damage the IBBS product if the system is not connected to a typical primary aircraft battery.

Ground Based Recharging:

To accomplish ground based charging connect an approved battery charger or power source to the main aircraft battery and energize the main aircraft power bus by turning on the master switch, leave all other aircraft loads in their off state. Note, the ground base source of power must be able to supply the load current of all devices that can not be turned off in this nominal state, plus the 3.75 amps of IBBS recharge current. Leave the ground based charging system connected and powered until the IBBS system completes its recharge cycle of its internal battery, for a fully discharged battery this may take up to two hours.

Battery Capacity:

The IBBS provides an energy capacity of 4 amp-hours at 12 volts when the system is fully charged. Depending on various conditions including operating and storage temperature and age of the battery pack, the capacity of the system will vary. With a fully charged battery, the following average performance can be expected in terms of operating duration. The operating duration is for output voltage down to 10 volts.

Nominal Current Draw total connected load	Duration
2.5 amps	95 minutes
4.0 amps	55 minutes
6.0 amps	35 minutes

The Ni-mh battery in the IBBS system is replaceable, however, the IBBS product must be returned to TCW Technologies, LLC. for this service. Battery life depends strongly on many factors including operating and storage temperature, number of discharge cycles and depth of discharge. The battery capacity should be checked at least annually for suitable back-up power operation of the connected equipment. When the battery capacity no longer meets the operating criteria of the aircraft it must be replaced. Contact TCW Technologies, LLC. for battery replacement.

Upon completion of installation:

- 1) The builder/operator is responsible for determining the minimum operating duration of the back-up enabled equipment.
- 2) The required back-up operating time for the connected equipment should be recorded in the aircraft log-book with follow-up entries confirming the annual testing results that indicate that the required operating time is satisfied.

Normal Product Operation:

For normal operation the following is the recommend operating procedure, it is strongly recommended that this operating procedure be added to the aircraft operating check-list for standard procedures.

Start-up Procedure:

- 1) Prior to turning on the Aircraft Master Switch, turn ON the Back-up Power master switch.
- 2) Turn on any equipment that derives back-up power from the IBBS product.

- 3) Ensure the connected equipment successfully boots-up and is operating properly. (During this period of time the equipment is running off of the back-up battery in the IBBS product. This test ensures the transfer circuit and back-up battery are properly working)
- 4) Turn on the Aircraft Master Switch, ensure the connected equipment remains energized.
- 5) Start and operate the aircraft according to normal operating procedures.

Shut-down Procedure:

- 1) Shut down aircraft engine using normal procedures.
- 2) Shut down the Aircraft Master Switch
- 3) Verify that equipment that derives back-up power from the IBBS product remains ON
- 4) Turn-off Back-up Power Master switch, ensure that equipment powers down. (This procedure further ensures the operation of the transfer circuit in the IBBS product.)

Emergency Procedure for loss of main aircraft electrical power:

- 1) Operate the Aircraft Master Power Switch per the Emergency Procedure checklist already established for the aircraft.
- 2) Ensure the Back-up Master Switch is in the ON position.
- 3) Land aircraft as soon as practical to resolve the loss of main electrical power

Requirements for continued airworthiness:

On at least an annual basis the endurance capability of the IBBS system shall be confirmed and compared against the back-up endurance required for the connected equipment.

As an alternate to these tests the IBBS unit may be returned to TCW Technologies for a loaded endurance test, contact TCW for details.

Procedure for endurance testing (all applications except electronic ignition systems):

- 1) Turn off the Aircraft Master Switch
- 2) Turn on the Back-up Power Master Switch
- 3) Turn on all equipment connected to and supplied with back-up power from the IBBS product.
- 4) Measure and record at least the following information: The time until the first piece of connected equipment no longer functions or the time until the output of back-up power supply voltage drops to 10.0 volts. AVOID allowing the back-up battery voltage to fall below 9 volts

- 5) After completing the endurance test, recharge the IBBS product by operating the system with the Aircraft Master Switch in the ON position for up to two hours. This may be done by operating the aircraft in conditions known to not require back-up power or by powering the aircraft system on a suitable ground power source as described in the section: Ground Base Recharging.
- 6) Record the results of the endurance testing in the aircraft log book.
- 7) If the IBBS no longer meets the endurance testing requirement, the back-up battery may need replacement.

Requirements for continued airworthiness: Electronic Ignition Back-up

On at least an annual basis the endurance capability of the IBBS system shall be confirmed and compared against the back-up endurance required for the connected equipment.

As an alternate to these tests the IBBS unit may be returned to TCW Technologies for a loaded endurance test, contact TCW for details.

Procedure for endurance testing of system providing back-up power to electronic ignition systems:

COMPLETE THESE STEPS IN ORDER! Perform these tests with the aircraft properly secured on the ground, these are not flight test procedures.

- 1) Start the aircraft using normal starting procedures, including turning ON the Back-up Master switch
- 2) Select engine operation based on the use of only the electronic ignition module provided with back-up battery power.
- 3) PULL the 5 amp breaker feeding the Back-up Master Switch, confirm engine continues to run.
- 4) PULL the 7.5 amp breaker feeding pin 6 of the IBBS, confirm the engine continues to run.
- 5) Perform the following; test A or test B:

Test A: abbreviated battery test:

Monitor engine operation and voltmeter reading on pin 7, back-up output wire. Confirm back-up voltage begins above 12.0 volts and for a period of 15 minutes remains above 11.5 volts. If these requirements are met the battery pack is satisfactory.

Test B: full endurance test:

Operate the engine on the electronic ignition system for the required minimum run-time requirement (typically 60 minutes) monitor the back-up battery voltage on the voltmeter connected to pin 7, the battery voltage must remain above 10 volts for the duration of the test. If this requirement is met the battery pack is satisfactory.

- 6) Turn off the Back-up Master Switch and confirm that the engine turns off.
- 7) IF all these tests pass, the IBBS system is functioning properly, record the results in the aircraft log book.
- 8) IF any of these tests fail, the IBBS system is not functioning properly and corrective action must take place. If the IBBS no longer meets the endurance testing requirement, the back-up battery may need replacement.
- 9) Return all pullable breakers to the normal ON position and ensure aircraft engine is properly returned to the off position by following normal run and shut down procedures.
- 10) After completing these tests, recharge the IBBS product by operating the system normally for up to two hours. This may done by operating the aircraft in conditions known to not require back-up power or by powering the aircraft system on a suitable ground power source as described in the section: Ground Base Recharging

TCW Technologies, LLC.
2955 Main Road East
Emmaus, PA 18049

610-928-3420
www.tcwtech.com
email: support@tcwtech.com

SPECIFICATIONS:

Input Voltage:	10-15 volts DC
Input Current	9.75 amps max continuous
Output Voltage:	10-12 volts DC during back-up operation
Output Current:	6 amps continuous 9 amps peak for radio transmissions and transient loads
Battery:	Internal sealed Ni-MH
Charger:	Integral high performance fast charger
Surge Protection:	16 volt active clamp, 1500w 10/1000uS waveform
Wiring:	CPC connector with Mil-spec machined connections
Enclosure:	Cast aluminum 4.74" x 3.13" x 2.17"
Weight:	2.5 lbs
Temperature range:	Operating -10 C° to 60 C° Charging 0 C° to 40 C°
Connectors:	AMP type CPC # 206486-2 on product wiring harness. AMP type CPC # 206485-1 is utilized on the aircraft wiring harness.

Wiring harness connector

Amp 206486-2 receptacle on IBBS product

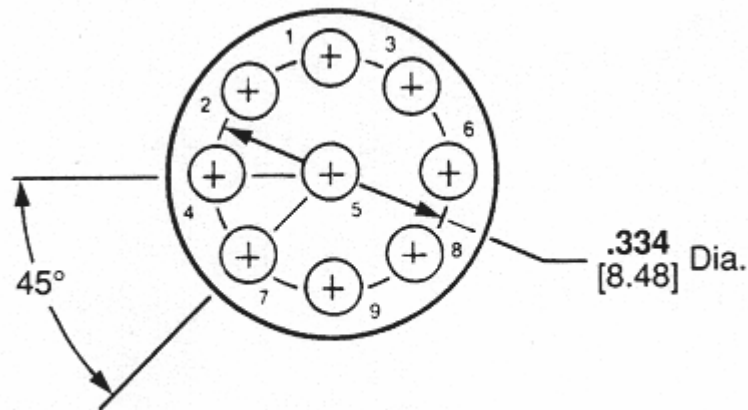

Arrangement 11-9
Max. Wire Ins. Dia. = .068 [1.73]

mating CPC connector AMP part # 206485-1 on aircraft harness

<u>PIN</u> <u>#</u>	<u>Description</u>	<u>Wire Color (optional harness)</u>
1	Main Aircraft Bus	Red
2	Aux Battery trickle charge, Always-ON	Purple/yellow
3	Aircraft ground	Black
4	Back-up power master switch	White/black
5	Info	Green/red
6	Main Aircraft Bus	Red
7	Back-up battery output	White
8	Back-up battery output	White
9	Back-up battery output	White

Wiring Diagram IBBS-12v-4ah

Equipment without Back-up Power Input

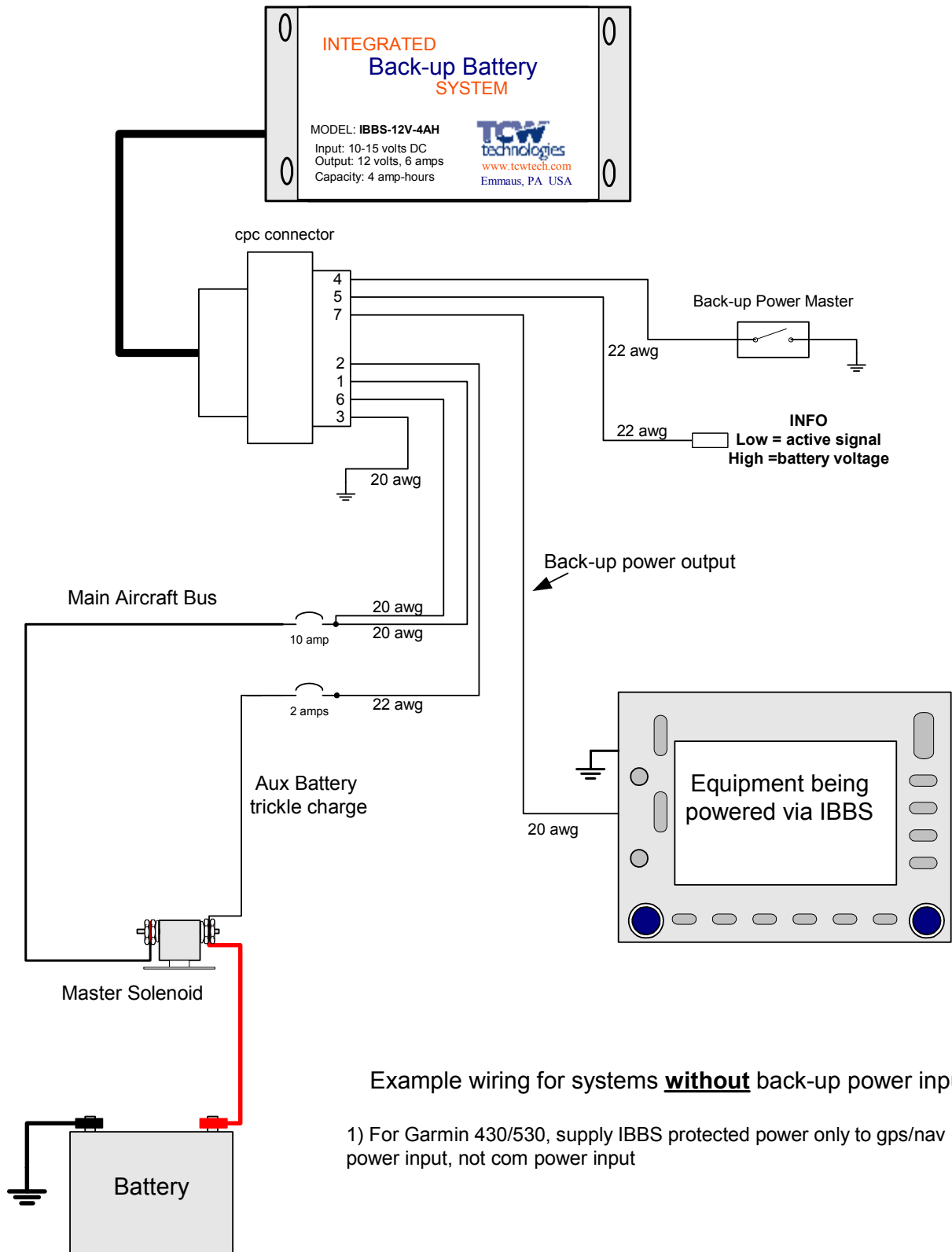

Example wiring for systems without back-up power inputs

- 1) For Garmin 430/530, supply IBBS protected power only to gps/nav power input, not com power input

Wiring Diagram IBBS-12v-4ah

Equipment with Back-up Power Input

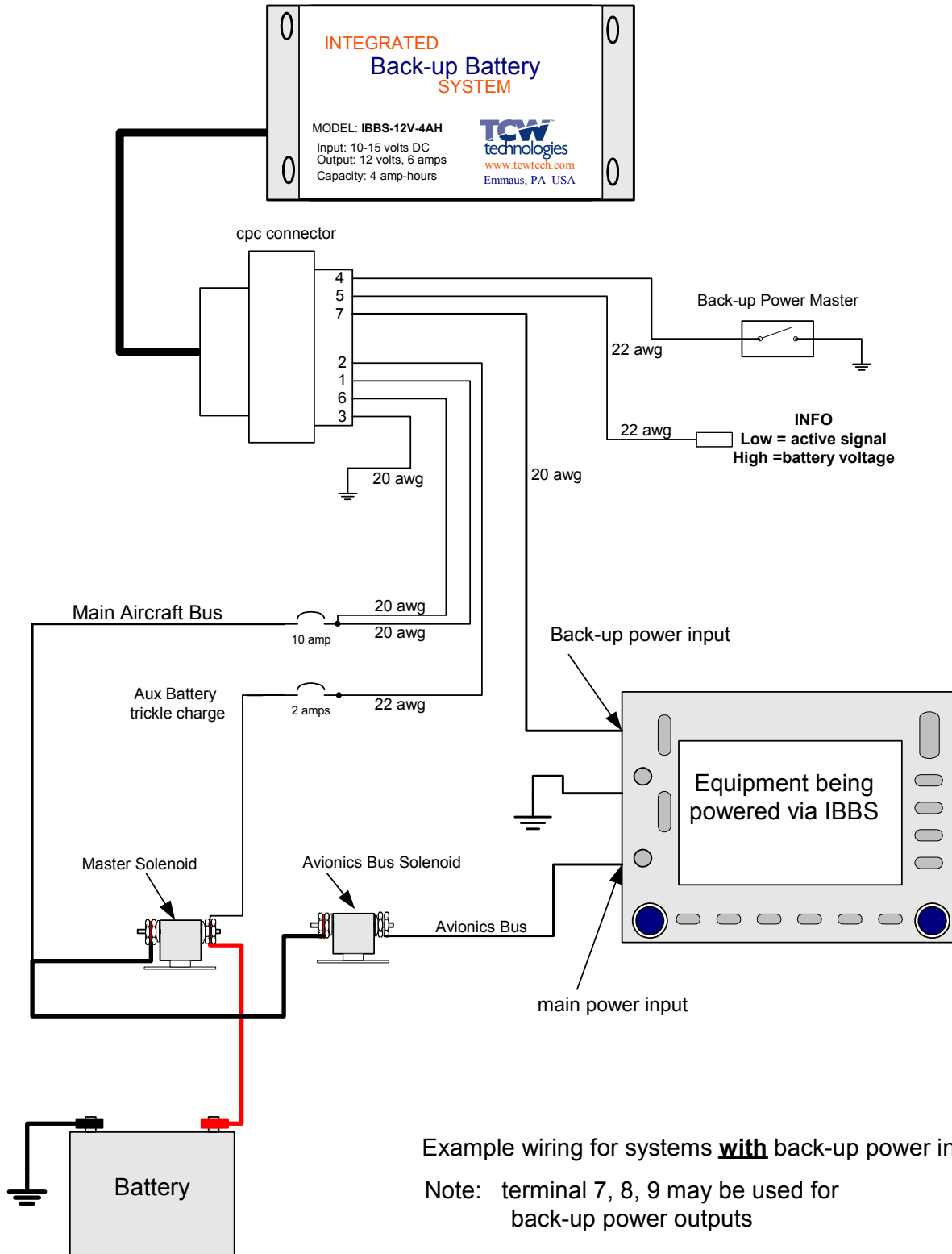

Wiring Diagram IBBS-12v-4ah

Multiple Pieces of equipment with Back-up Power Input

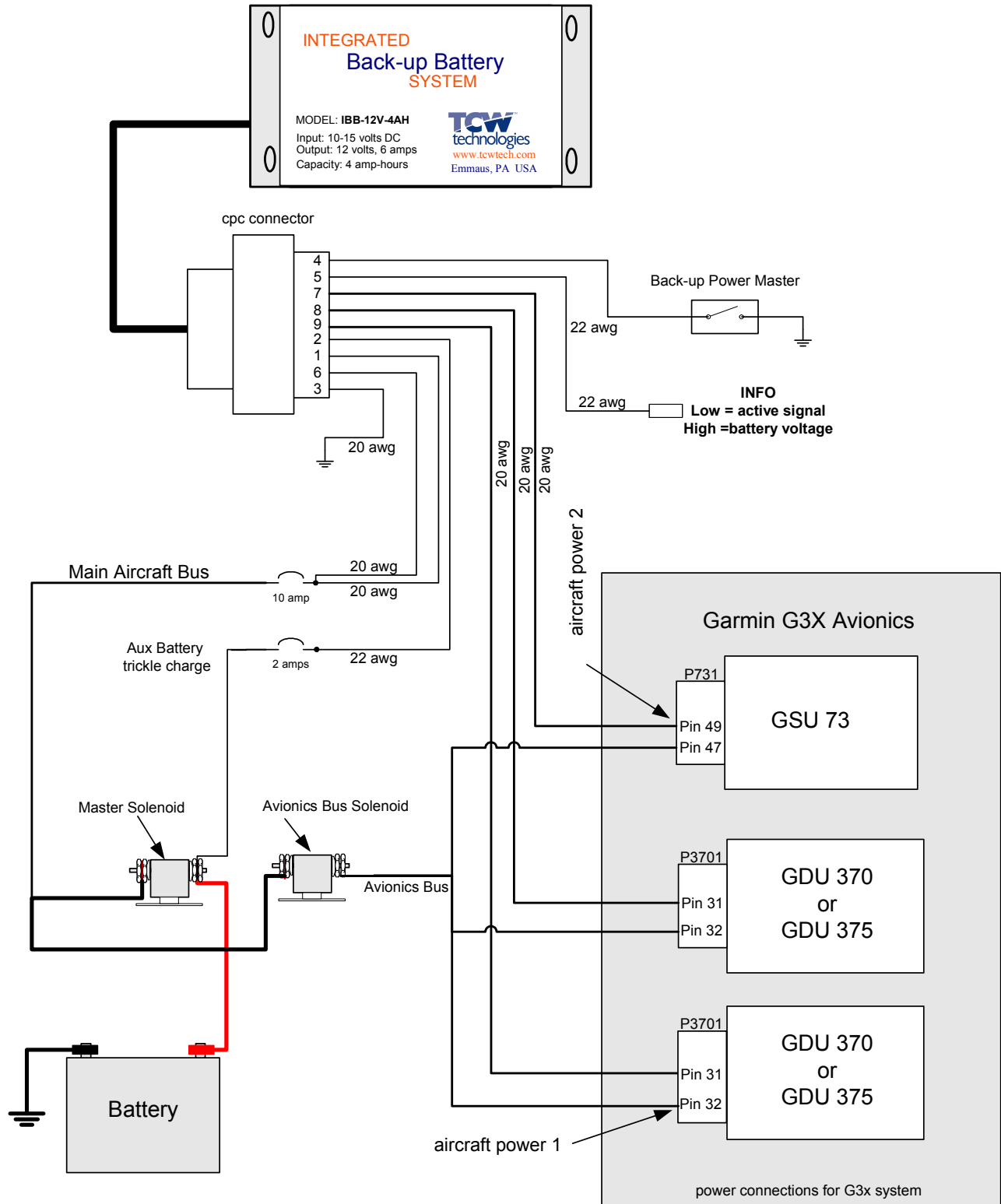

Wiring Diagram IBBS-12v-4ah

Garmin 430/530 including Com Radio back-up

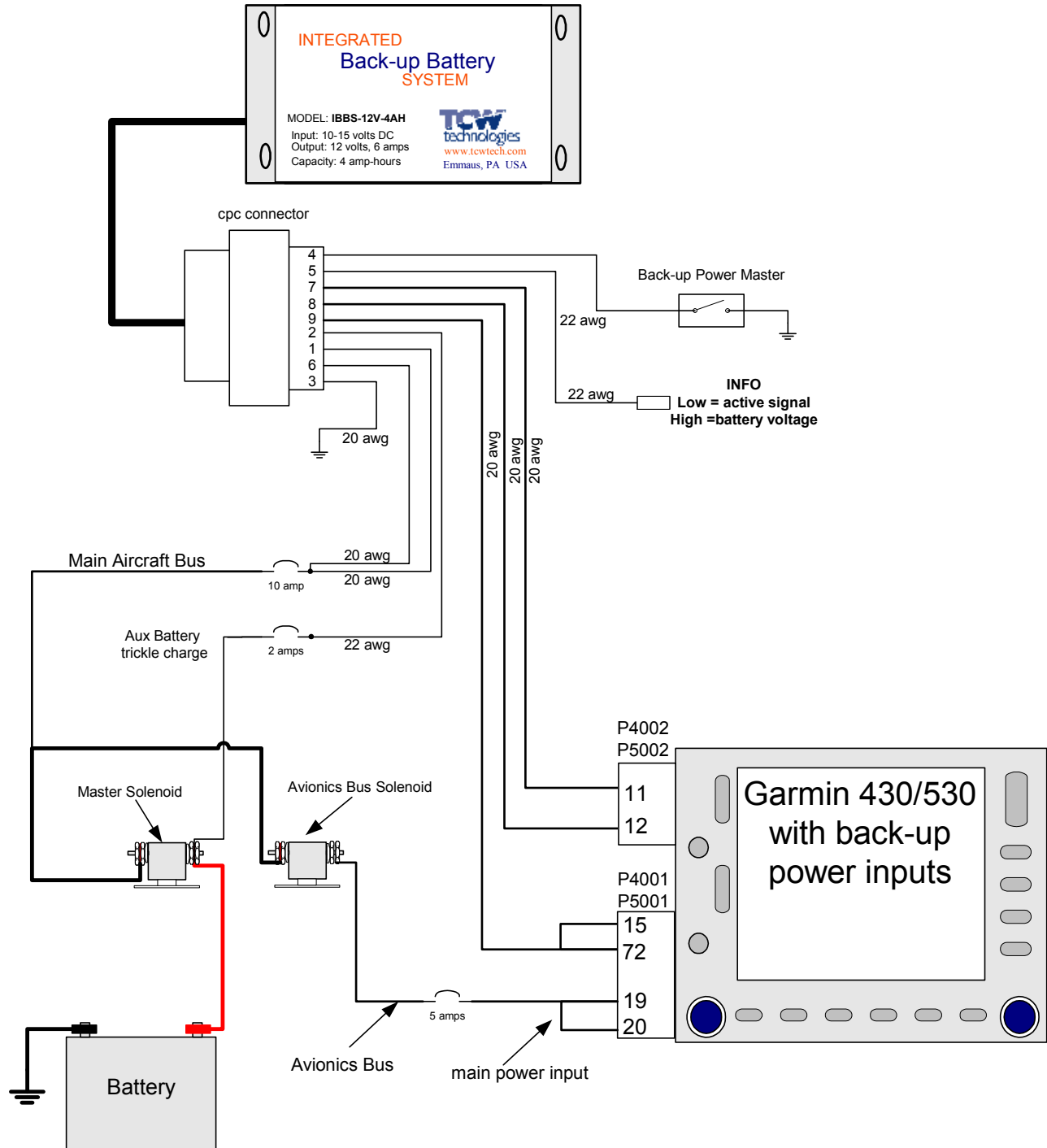

Example wiring for back-up power to a Garmin 430/530 system including back-up of Com Radio

Wiring Diagram IBBS-12v-4ah

Back-up of ONE CDI in a single or dual CDI installation. Use with LSE Plasma II and III electronic ignition

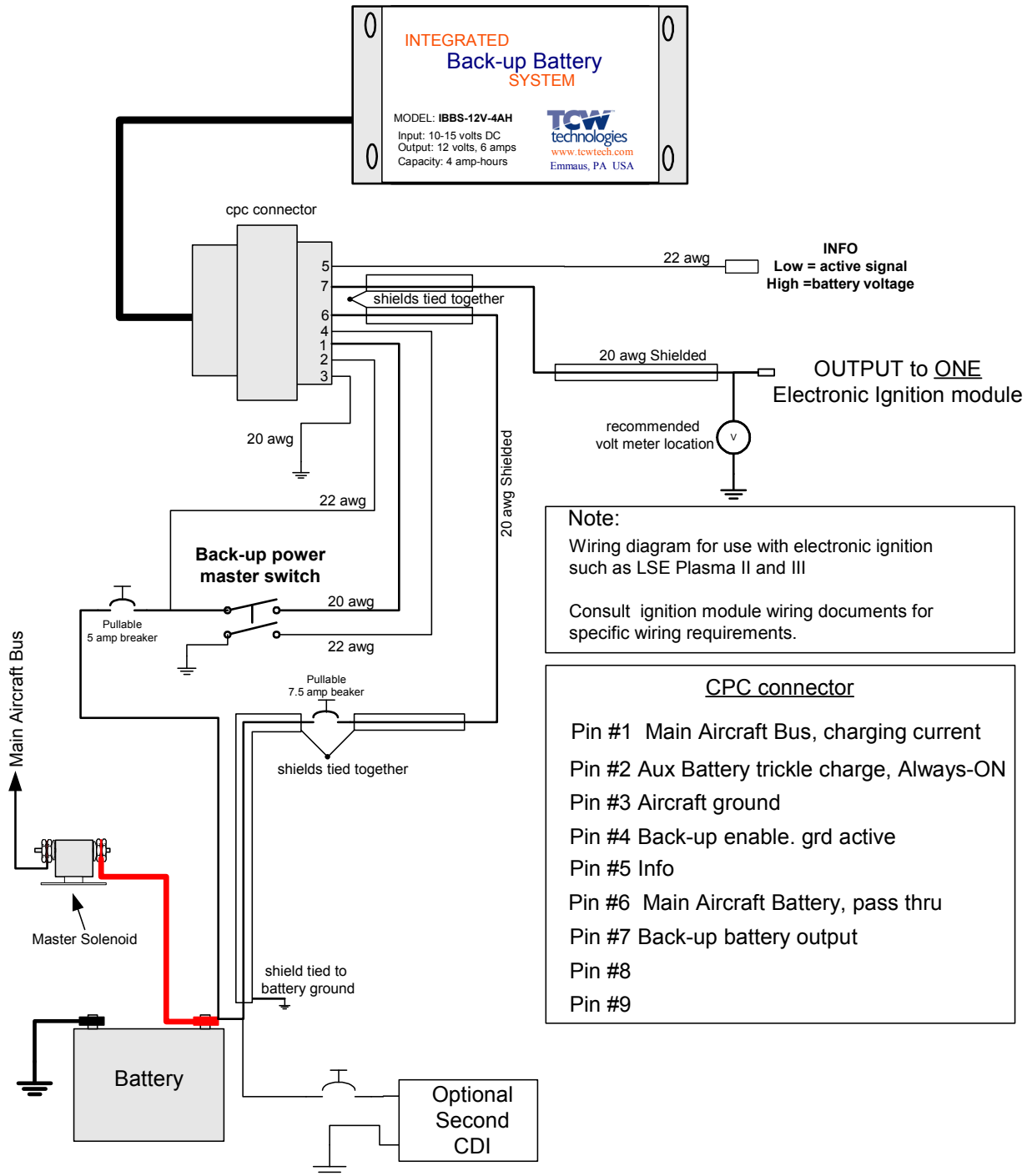

TCW Technologies, LLC.

During the first 12 months from the date of purchase and subject to the conditions hereinafter set forth, TCW Technologies, LLC. (TCW) will repair or replace to the original user or consumer any portion of your new TCW product which proves defective due to defective materials or workmanship of TCW. Contact TCW Technologies for warranty service. TCW shall have and possess the sole right and option to determine whether to repair or replace defective equipment, parts or components. Damage due to equipment, environment or conditions beyond the control of TCW Technologies are NOT COVERED BY THIS WARRANTY.

LABOR, COSTS: TCW shall IN NO EVENT be responsible or liable for the cost of field labor or other charges incurred by any customer in removing and/or reaffixing any TCW product, part or component thereof.

THIS WARRANTY WILL NOT APPLY: (a) to defects or malfunctions resulting from failure to properly install, operate or maintain the unit in accordance with printed instructions provided; (b) to failures resulting from abuse, accident, or negligence; (c) to normal maintenance services and the parts used in connection with such service; (d) to units which are not installed in accordance good trade practices; or (e) to unit used for purposes other than for what it was designed and manufactured.

RETURN OR REPLACED COMPONENTS: any item to be replaced under this Warranty must be returned to TCW Technologies in Emmaus, PA, or such place as TCW may designate, freight prepaid.

PRODUCT IMPROVEMENTS: TCW reserves the right to change or improve its products or any portions thereof without being obligated to provide such a change or improvement for units sold and /or shipped prior to such change or improvement.

WARRANTY EXCLUSIONS: as to any specific TCW product, after the expiration of the time period of the warranty applicable thereto as set forth above. THERE WILL BE NO WARRANTIES, INCLUDING ANY IMPLIED WARRANTIES OR MERCHANTABILITY OR FITNESS FOR ANY PARTICULAR PURPOSE.

Some states do not allow limitations on how long an implied warranty lasts, so the above limitation may not apply to you. No warranties or representations at any time made by any representative of TCW shall vary or expand the provisions hereof.

LIABILITY LIMITATION: IN NO EVENT SHALL TCW OR ITS AFFILIATES BE LIABLE OR RESPONSIBLE FOR CONSEQUENTIAL, INCIDENTAL OR SPECIAL DAMAGES RESULTING FROM OR RELATED IN ANY MANNER TO ANY TCW PRODUCT OR PARTS THEREOF. THE SUITABILITY OF USE OF THE TCW TECHNOLOGIES, LLC. PRODUCT IS TO BE DETERMINED BY THE AIRCRAFT BUILDER.

Some states do not allow the exclusion or limitation of incidental or consequential damages, so the above limitation or exclusion may not apply to you.

This Warranty gives you specific legal rights and you may also have other rights which vary from state to state. In the absence of other suitable proof of this installation date, the effective date of this Warranty will be based upon the date of manufacture plus one year. Direct All Notices To: Warranty and Product Service Department, TCW Technologies, 4906 Raymond Ct. Emmaus, PA 18049