

Microair Avionics

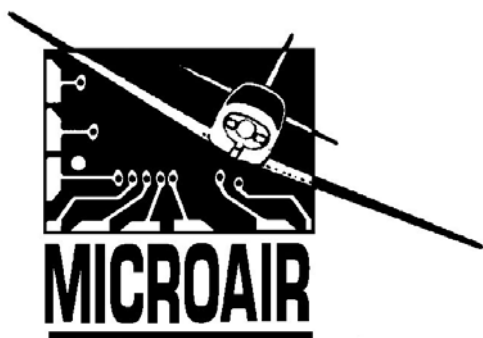

T2000SFL TRANSPONDER INSTALLATION MANUAL



Microair Avionics Pty Ltd

Airport Drive
Bundaberg
Queensland 4670
Australia

Tel: +61 7 41 553048

Fax: +61 7 41 553049

e-mail: support@microair.com.au

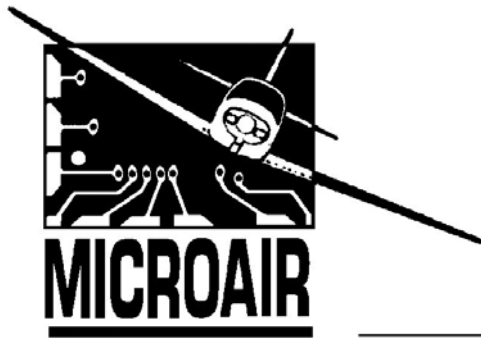

About This Document

This manual describes the various installation configurations available for the Microair T2000SFL Transponder, including connection to a separate altitude encoder.

Microair reserve the right to amend this manual as required, reflecting any enhancements or upgrades to the T2000 Transponder series.

© Microair Avionics Pty Ltd



DOCUMENT REVISION STATUS

Revision	Date	Change
1.0	11/02/01	Initial Draft
1.1	25/05/01	Remote display references removed
2.0	11/07/01	Part Identification Revision
2.1	07/11/01	Deleted SF references
2.2	01/06/02	Pin assignments and wiring diagram updated
2.3	13/08/03	Coaxial loss data updated
2.4	30/10/04	Additional antenna and coax data added
2.5	08/04/05	Software upgraded to 05-1.6.4
01R3	19/05/06	Software upgraded to 01R1-6-5 software Amended document references
01R4	03/06/06	Additional encoder wiring data added
01R5	17/12/06	Multi-Function Display wiring data added
01R6	08/05/07	Wiring diagrams updated
01R7-0	19/07/08	Audited for use with Revision 7 transponders

TABLE OF CONTENTS

1.0	INTRODUCTION	4
1.1	MOUNTING OPTIONS	4
1.2	INSTALLATION REFERENCES	4
2.0	PANEL MOUNTING	5
3.0	MODE C ENCODER	6
4.0	ANTENNA	7
4.1	MOUNTING	7
4.2	GROUND PLANE	7
5.0	COAXIAL CABLE	8
6.0	WIRING	9
6.1	GENERAL WIRING	9
6.2	AUDIO BEEP	10
6.3	SUPPRESSION IN	10
6.4	SUPPRESSION OUT	10
6.5	EXTERNAL STANDBY	10
6.6	EXTERNAL IDENT	10
7.0	CALIBRATION OF INSTALLATION	11
8.0	WIRING DIAGRAMS	12
9.0	INSTALLATION DIMENSIONS	19
10.0	PIN ASSIGNMENTS	20
11.0	PANEL TEMPLATE	21
12.0	SPECIFICATIONS	22
13.0	WARRANTY CARD	23

1.0 INTRODUCTION

It would be a really good idea if you read through this section of the manual **BEFORE** you start installing your Microair T2000SFL Transponder. If it is too late, and you are reading this message after the fact, perhaps the information that follows can help you sort things out.



IMPORTANT NOTE

Installation of this transponder should be carried out or inspected by a qualified installer.

1.1 MOUNTING OPTIONS

The T2000 Transponder series has a number of mounting options. The **SFL** round face unit can have:

Panel mounting

Remote display mounting (refer to T2000SFL Remote Display Manual 01R3)

1.2 INSTALLATION REFERENCES

The Microair T2000SFL Transponder should be installed in accordance with the instructions and information of this manual and FAA AC 43.13-1A Chapter 11.

2.0 PANEL MOUNTING

If standard mounting is desired (no remote display unit), determine a suitable location in the instrument panel in full view of both pilots. Cut a 57mm diameter (2 ¼ inch) hole with 4 x 4mm holes for the mounting screws. Dimensions for this are provided on the panel template. Allow a minimum of 63mm (2 ½ inch) square, behind the cut out, to allow clearance from other instruments. A depth of 180mm (7 inches) is recommended to accommodate the transponder and electrical connectors.

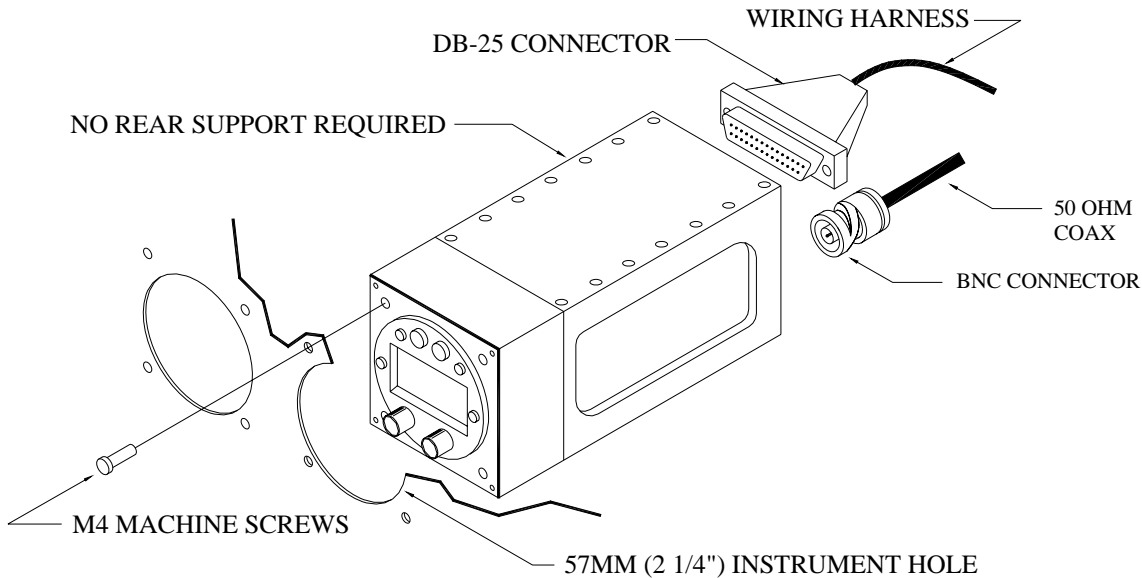

MICROAIR T2000 SFL
PANEL INSTALLATION

The T2000SFL weights only 600g (1 lbs). The four M4 x 12mm machine screws are sufficient to support the transponder. No rear support is required unless the panel structure itself is too weak to support the load.

IMPORTANT NOTE

Removal of the chassis screws for the purpose of attaching support bracket is not permitted.

The drilling of holes in the chassis for any purpose is not permitted.

Filings from changing the thread of the M4 screw may cause electrical faults. Faults of this type are NOT covered by the warranty.



3.0 MODE C ENCODER

Mount the mode C blind encoder as per the manufacturer's installation instructions. All wiring can be run back to the T2000SFL for connection (refer wiring diagram). The power for the encoder is supplied from the T2000SFL, and is equal to the aircraft supply voltage. This power is switched when the T2000SFL is turned on.

If the encoder is to be powered separately, it is recommended that the ground wire is run to the T2000SFL, to ensure correct switching of the data lines.



IMPORTANT NOTE

Most encoder manufacturers advise of a warm up period for their product before altitude data is supplied. The period can typically be up to 10 minutes.

The T2000SFL software offers the option of leaving the encoder unpowered until mode C operation is selected. This option is useful for operators using battery power only. A power saving of approx 200mA can be made. Refer to the **PROGRAM MODE** item **E/C POW** (in the T2000SFL User Manual) for this setting.



IMPORTANT NOTE

If the aircraft voltage is 28V and the encoder is 14V only, a 28/14V converter should be installed between the T2000SFL and the encoder.

Please ensure that the voltage supply line to power the encoder is NOT shorted to any data line or ground. The T2000SFL will incur internal faults if a short occurs. This type of damage is NOT covered by the warranty.

Refer to WIRING DIAGRAMS section for wiring details and pin assignments for commonly used altitude encoders.

4.0 ANTENNA

The T2000SFL requires an antenna tuned to 1090MHz. Microair recommends the use of a TSO'd antenna for transponder purpose.

4.1 Mounting

The transponder signal is primarily directed to ground stations (Radar sites), hence the antenna is typically located on the underside of the fuselage. The position should give the antenna a full 360 degree view of the horizon. The position should be away from other protrusions from the airframe, such as footsteps, and undercarriage legs.

To avoid possible interference the antenna must be mounted a minimum of 0.3m (12 inches) away from the **T2000SFL**. The transponder antenna outputs high level of RF energy, and should be located at least 1m (3ft) away from vulnerable part of the human body, or be separated by a metal panel.

If the VHF comm. Antenna is already located on the underside of the fuselage, the transponder antenna should be located at least 1 metre (3ft) away. The transponder antenna should be mounted 2metres (78 inches) from the **DME** antenna, 1.5 metres (58 inches) from the **ADF** sense antenna, and 1metre (39 inches) from **TCAS** antennas.

4.2 Ground Plane

In metal skin aircraft the skin forms the ground plane. To ensure a good electrical connection, it may be necessary to remove paint/primer from the inside face of the skin, before attaching the antenna. This may be resealed after the antenna is installed. On pressurised aircraft, the antenna should be sealed using RTV-3145 or equivalent, to seal around the connector and mounting hardware. All antenna mounts should be sealed around the outside for moisture protection, using RTV-3145 or equivalent.

In a composite aircraft the skin of the airframe cannot be used, and a suitable ground plane must be fabricated. The ground plane is typically an aluminium disc with a radius equal to the height of the antenna (approx. 75mm or 3"). The antenna is mounted in the centre of the ground plane.

The ground plane does not have to be circular however, but the area should be approx the same size. Fibreglass aircraft can mount the ground plane on the inside of the aircraft.

Although carbon fibre is a good reflector of RF, it is not a suit material for a ground plane. A metal ground plane located outside the aircraft is ideal.

It is important to ensure that a good electrical contact is established, as some antennas have sealing O-rings which can isolate this connection.



5.0 COAXIAL CABLE

The T2000SFL allows for 1.5dB cable loss from the unit to the antenna. The installer should consider carefully what type of coaxial cable is to be used, so that this loss limit is not exceeded. The cable should be terminated with silver plated BNC connectors where possible.

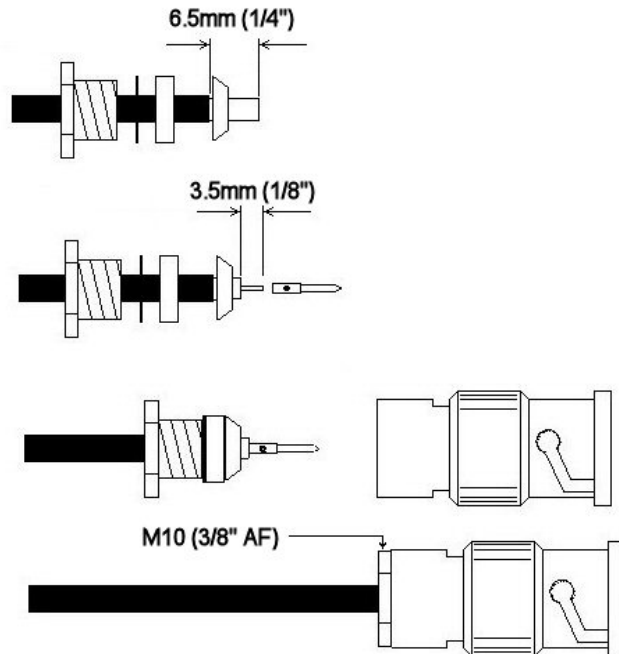

Microair recommends the following:

Cable	Bending Radius	Loss @ 1Ghz dB/m	Max Length	TX Power	RX Sensitivity
RG58/C/U (Mil Spec)	50mm (2")	0.76dB/m 0.21dB/ft	2.0m 7ft	142W	-70dBm
RG213/A/U (Mil Spec)	125mm (5")	0.26dB/m 0.08dB/ft	5.75m 19ft	142W	-70dBm
RG223/U (Mil Spec)	100mm (4")	0.47dB/m 0.14dB/ft	3.2m 10ft	142W	-70dBm
RG400 (Mil Spec)	50mm (2")	0.60dB/m 0.18dB/ft	2.5m 8ft	142W	-70dBm
Belden 8262	50mm (2")	0.68dB/m 0.21dB/ft	2.2m 7ft	142W	-70dBm
URM-43	50mm (2")	0.47dB/m 0.14dB/ft	3.2m 10ft	142W	-70dBm



IMPORTANT NOTE

Do not exceed the minimum bending radius. Tight bends will introduce losses in the cable, which may affect the performance of the transponder.

When fixing the coax cable in the airframe, do not "strangle" the cable with tight cable ties. This can distort or damage the coax screen.

6.0 WIRING

The T2000SFL must be installed with a wiring harness which meets the following requirements.

6.1 General Wiring

Microair recommends that the encoder be installed and wired in accordance with the manufacturer's installation instructions. The encoder can be powered directly from the T2000SFL. The T2000SFL is to be powered from the aircraft supply, via the avionics master and fuse/circuit breaker with a **maximum** 5 amp rating (3 amp minimum).

IMPORTANT NOTE

The aircraft's electrical system may produce severe transient voltages during engine start and stop



Microair recommends that the avionics master be turned off during engine start and stop, to prevent damage occurring to the T2000SFL.

Damage to the transponder as a result of transient voltages is NOT covered by the warranty.

It is very important to secure all D series plugs via their security screws before operation. Aircraft vibration may disconnect a D series plug if it not secured. Where possible, wiring is to be run separately to the coaxial cable.

Microair recommends that wiring for all of the T2000SFL's functions and connections be run at the time of installation, even though they may not be required at this stage. Adding additional wiring to the loom at a later stage may be very difficult. All wiring should be installed in accordance with FAA AC43.13-1A Chapter 11 or equivalent.

Microair recommends the following cable types for connection of the T2000SFL:

Power Input	18 AWG TEFZEL 22759/16-16	Red and Black Wire
External Connections	22 AWG TEFZEL 22759/16-22 22 AWG TEFZEL 27500-22TG1T14	Wire or Single core shielded
Encoder Power	22 AWG TEFZEL 22759/16-22	Red and Black Wire
Encoder Data	22 AWG TEFZEL 22759/16-22	White Wire

To ensure correct installation and to make future service simple, Microair recommends that all wiring be labelled for easy identification.

6.2 Audio Beep

The T2000SFL beep function when set to ON, will emit a beep tone on this line. Audio beep should be taken to the Auxiliary input of the aircraft's radio or Audio Panel.

When connecting the beep function to the Microair M760 transceiver, simply join the beep line directly to any headphone line (orange wire in factory supplied harness).

6.3 Suppression IN

The suppression IN line is used by the primary transponder in the aircraft to "suppress" the T2000SFL, to prevent dual transmissions, and interference. When the primary transponder transmits, it will send a positive voltage to the suppression IN, which prevents the T2000SFL from transmitting.

The T2000SFL requires a minimum signal voltage of 5V. The signal voltage may not exceed 20V.

6.4 Suppression OUT

Where the T2000SFL is the primary transponder, the suppression OUT line is used to prevent other transponder and DME equipment installed in the aircraft, from interfering. When the T2000SFL transmits, it raises a positive voltage on the suppression OUT line, which prevents the other equipment from transmitting.

The signal voltage is 5V.

6.5 External Standby

The external standby can be wired to a remote switch. When the line is taken to ground the T2000SFL will return to standby mode, and stay there regardless of the position of the Selectmode knob. The REM STBY function can reverse this operation to make the T2000SFL go to standby, when the external standby is not grounded.

This line is typically taken to an air-switch, which will remain grounded while the airspeed is typically below 30 knots. Hence the transponder will not come out of standby mode until the aircraft has taken off. If the external Standby Switch is to be taken to an air-switch, Microair recommends that an ON/OFF switch be put in series to disable the air-switch operation if required.

Where the external standby line is to be operated by an air-switch, Microair recommends that a placard be fitted on the panel.

**AIR-SWITCH FITTED TO EXTERNAL STANDBY
TRANSPONDER WILL REMAIN IN STANDBY
WHILE AIRCRAFT IS ON THE GROUND**

(example)

This placard is to advise the pilot that the transponder will remain in standby operation while on the ground. It may be appropriate to fit an enable/disable switch on the external standby line, between the transponder and the air-switch, to bypass this mode of operation.

6.6 External Ident

This line is typically wired to a momentary-ON switch, in a position more easily reached by the pilot / co-pilot (e.g. control column). When this line is taken to ground *briefly*, the T2000SFL will go through its Ident function.



IMPORTANT NOTE

If any of the above wiring functions are not required, they can simply be left not wired.

7.0 CALIBRATION OF INSTALLATION

Please refer to the Civil Aviation rules or regulations for your country to determine what the calibration requirements are, for a transponder installation.

Most countries will require a test of the installation to be carried out by a qualified test centre, along with a calibration of the encoder and altimeter in the aircraft.

This test is typically repeated every two years, to ensure the ongoing accuracy of the system.

Refer to FAA FAR Part 43 appendix E and F for typical transponder/encoder/altimeter equipment calibration procedures.

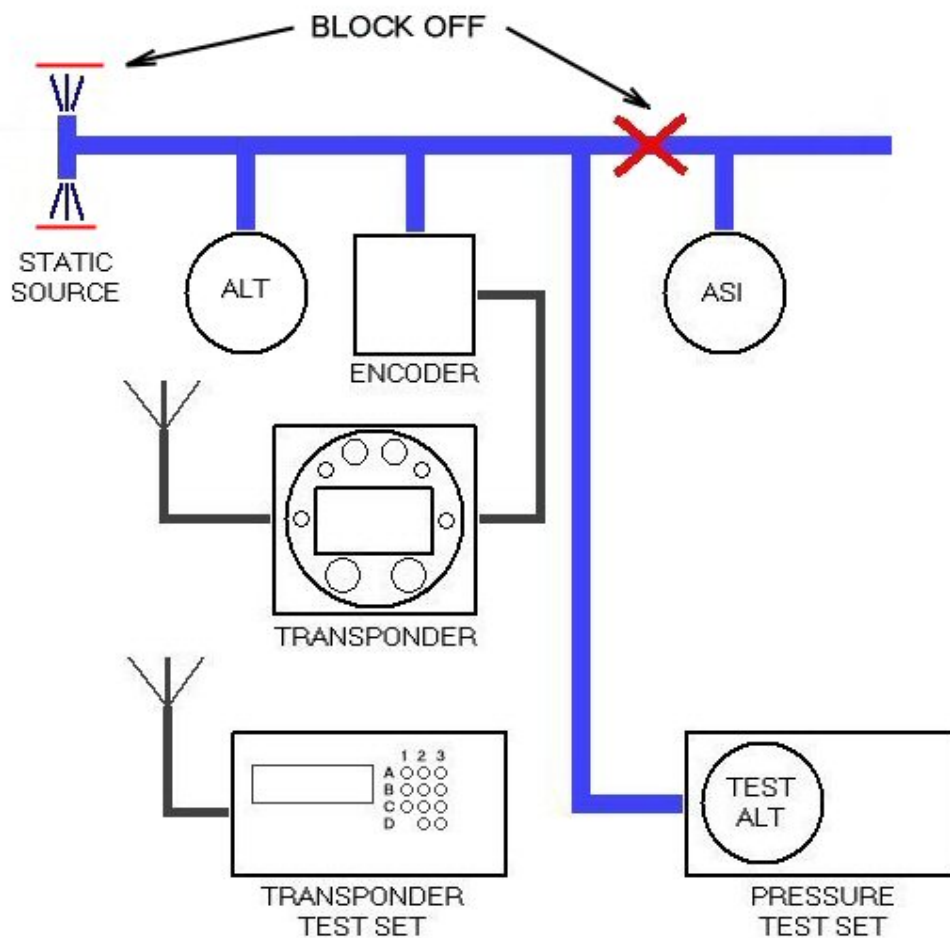

IMPORTANT NOTE

It is vital to aircraft safety that all transponder/encoder/altimeter systems, which will operate within an SSR system or interact with TCAS equipped aircraft, perform to a minimum civil aviation standard.

For this reason Microair strongly recommends that all transponder installations be calibrated at the time of installation, and at periods of not greater than two years thereafter.

8.0 WIRING DIAGRAMS

T2000SFL with EC2002 Altitude Encoder

T2000SFL with AK-350 Altitude Encoder

T2000SFL with A-30 Altitude Encoder

T2000SFL with Enigma Multi-Function Display

T2000SFL with Dynon D10A Multi-Function Display

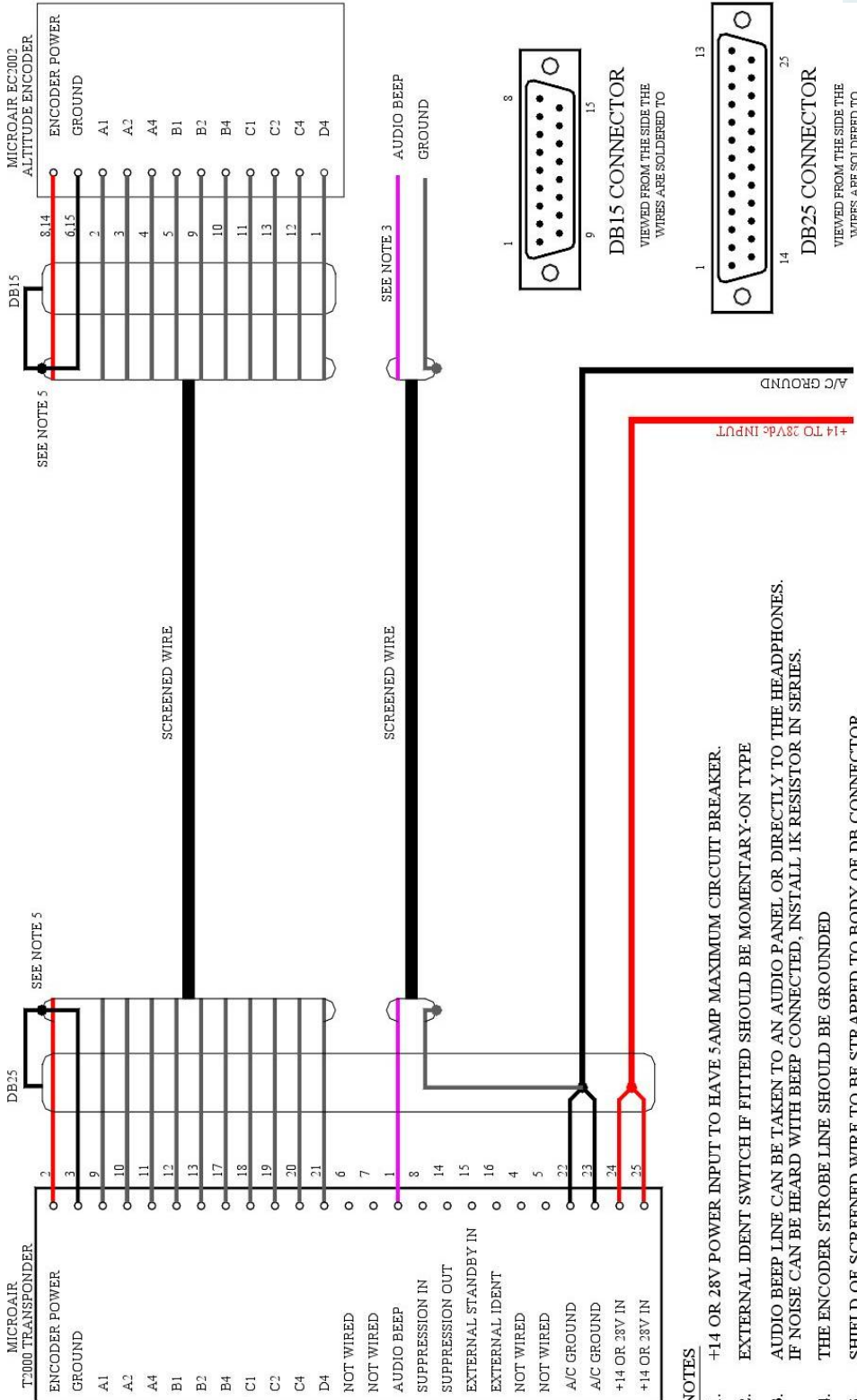

NOTES

1. +14 OR 28V POWER INPUT TO HAVE 5AMP MAXIMUM CIRCUIT BREAKER.
2. EXTERNAL IDENT SWITCH IF FITTED SHOULD BE MOMENTARY-ON TYPE
3. AUDIO BEEP LINE CAN BE TAKEN TO AN AUDIO PANEL OR DIRECTLY TO THE HEADPHONES. IF NOISE CAN BE HEARD WITH BEEP CONNECTED, INSTALL 1K RESISTOR IN SERIES.
4. THE ENCODER STROBE LINE SHOULD BE GROUNDED
5. SHIELD OF SCREENED WIRE TO BE STRAPPED TO BODY OF DB CONNECTOR.
6. HARNESS LENGTHS OF 600MM (+/- 25MM) ARE TO BE AVOIDED TO REDUCE THE INSTANCE OF RF INTERFERENCE FROM VHF RADIO.
7. THIS DIAGRAM IS APPLICABLE TO REVISIONS 5, 6, & 7.

MICROAIR T2000SFL - WIRING DIAGRAM WITH MICROAIR EC2002 ENCODER

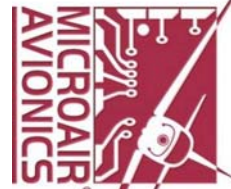

- NOTES**
1. +14 OR 28V POWER INPUT TO HAVE 5AMP MAXIMUM CIRCUIT BREAKER.
 2. EXTERNAL IDENT SWITCH IF FITTED SHOULD BE MOMENTARY-ON TYPE
 3. AUDIO BEEP LINE CAN BE TAKEN TO AN AUDIO PANEL OR DIRECTLY TO THE HEADPHONES. IF NOISE CAN BE HEARD WITH BEEP CONNECTED, INSTALL 1K RESISTOR IN SERIES.
 4. THE ENCODER STROBE LINE SHOULD BE GROUNDED
 5. SHIELD OF SCREENED WIRE TO BE STRAPPED TO BODY OF DB CONNECTOR.
 6. HARNESS LENGTHS OF 600MM (+/- 25MM) ARE TO BE AVOIDED TO REDUCE THE INSTANCE OF RF INTERFERENCE FROM VHF RADIO.
 7. THIS DIAGRAM IS APPLICABLE TO REVISIONS 5, 6, & 7.

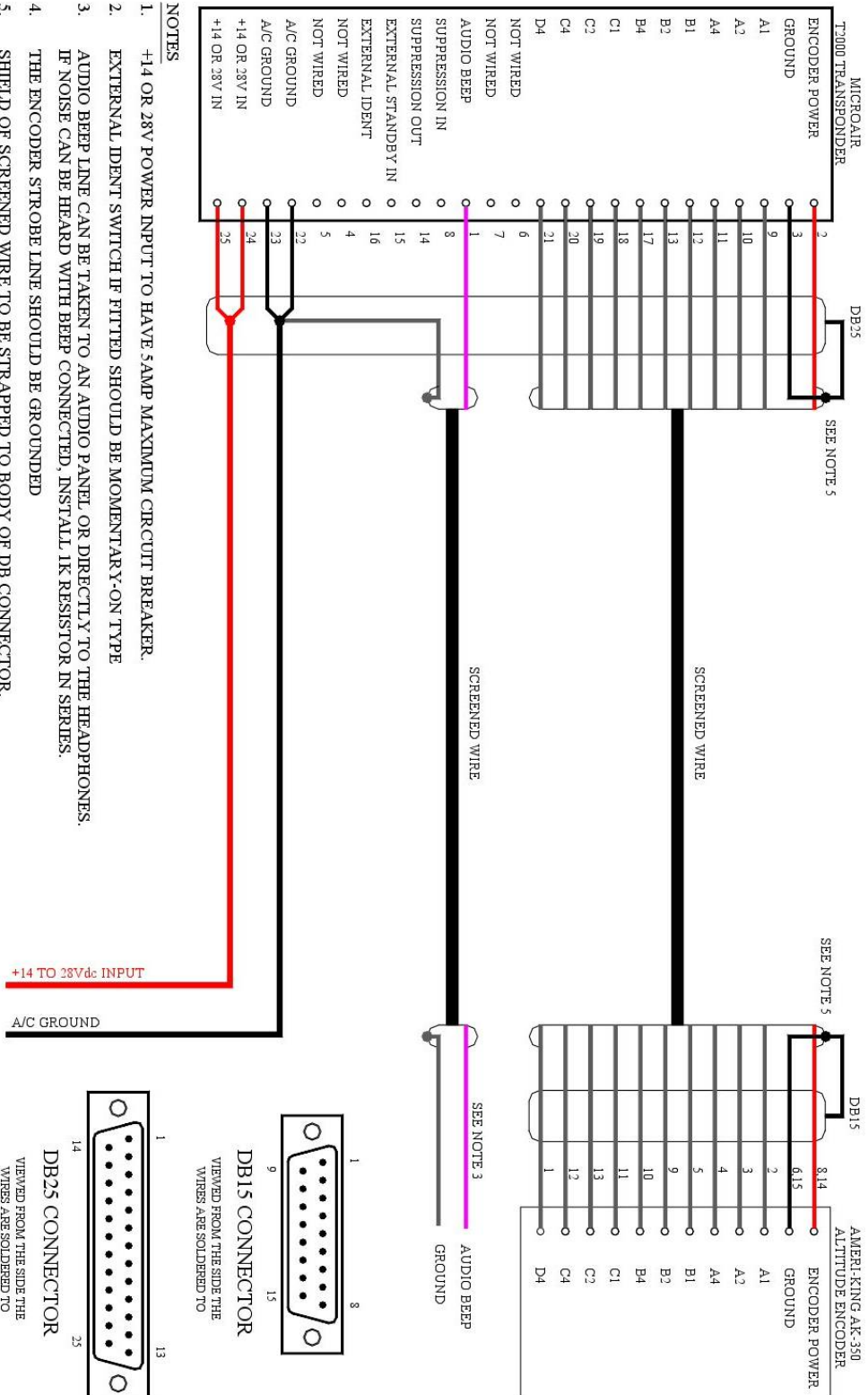

MICROAIR T2000SFL - WIRING DIAGRAM

WITH AMERI-KING AK-350 ENCODER

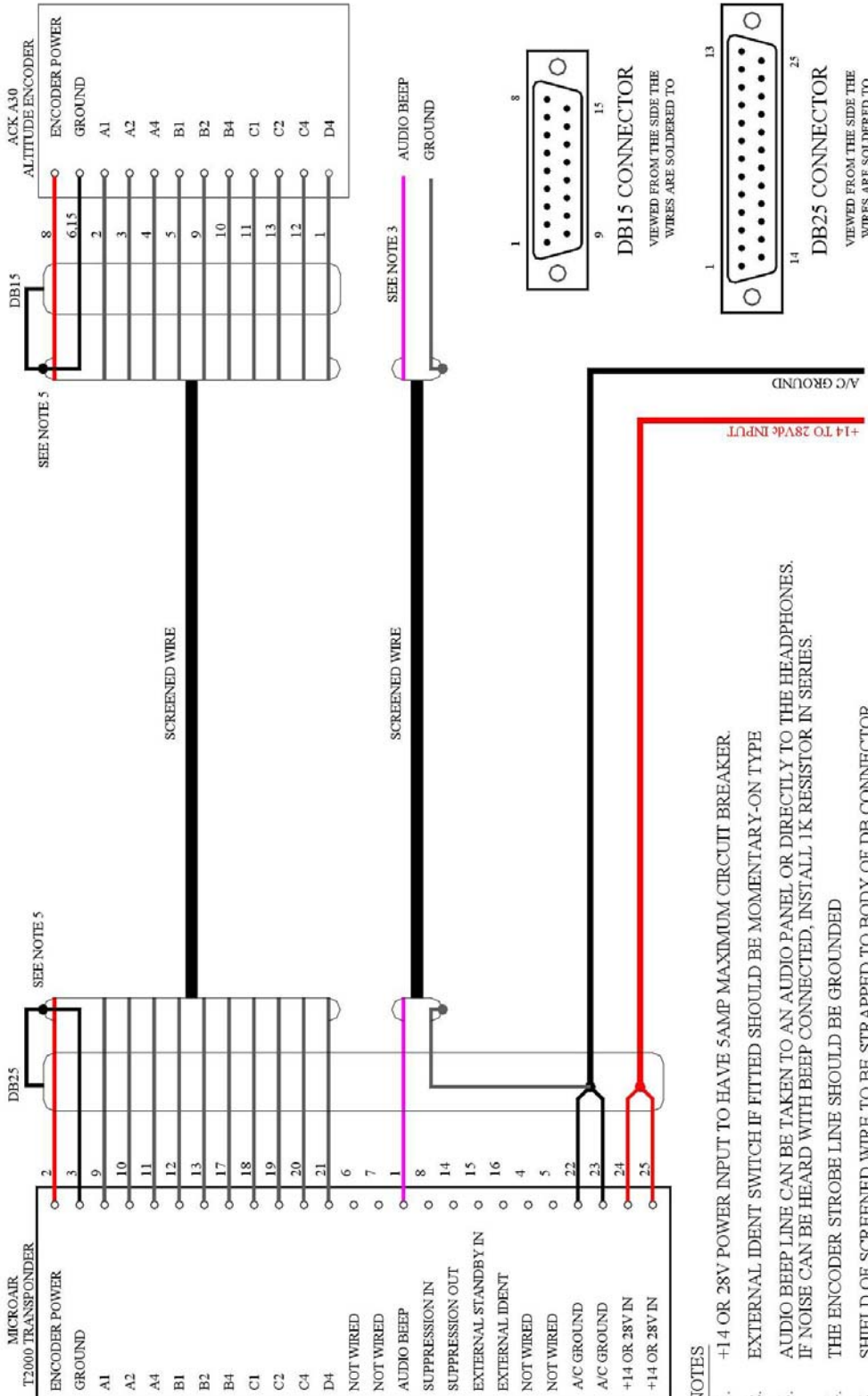

- NOTES**
1. +14 OR 28V POWER INPUT TO HAVE SAMP MAXIMUM CIRCUIT BREAKER.
 2. EXTERNAL IDENT SWITCH IF FITTED SHOULD BE MOMENTARY-ON TYPE
 3. AUDIO BEEP LINE CAN BE TAKEN TO AN AUDIO PANEL OR DIRECTLY TO THE HEADPHONES. IF NOISE CAN BE HEARD WITH BEEP CONNECTED, INSTALL 1K RESISTOR IN SERIES.
 4. THE ENCODER STROBE LINE SHOULD BE GROUNDED
 5. SHIELD OF SCREENED WIRE TO BE STRAPPED TO BODY OF DB CONNECTOR.
 6. HARNESS LENGTHS OF 600MM (+/- 25MM) ARE TO BE AVOIDED TO REDUCE THE INSTANCE OF RF INTERFERENCE FROM VHF RADIO.
 7. THIS DIAGRAM IS APPLICABLE TO REVISIONS 5, 6, & 7.

MICROAIR T2000SFL - WIRING DIAGRAM WITH ACK A30 ENCODER

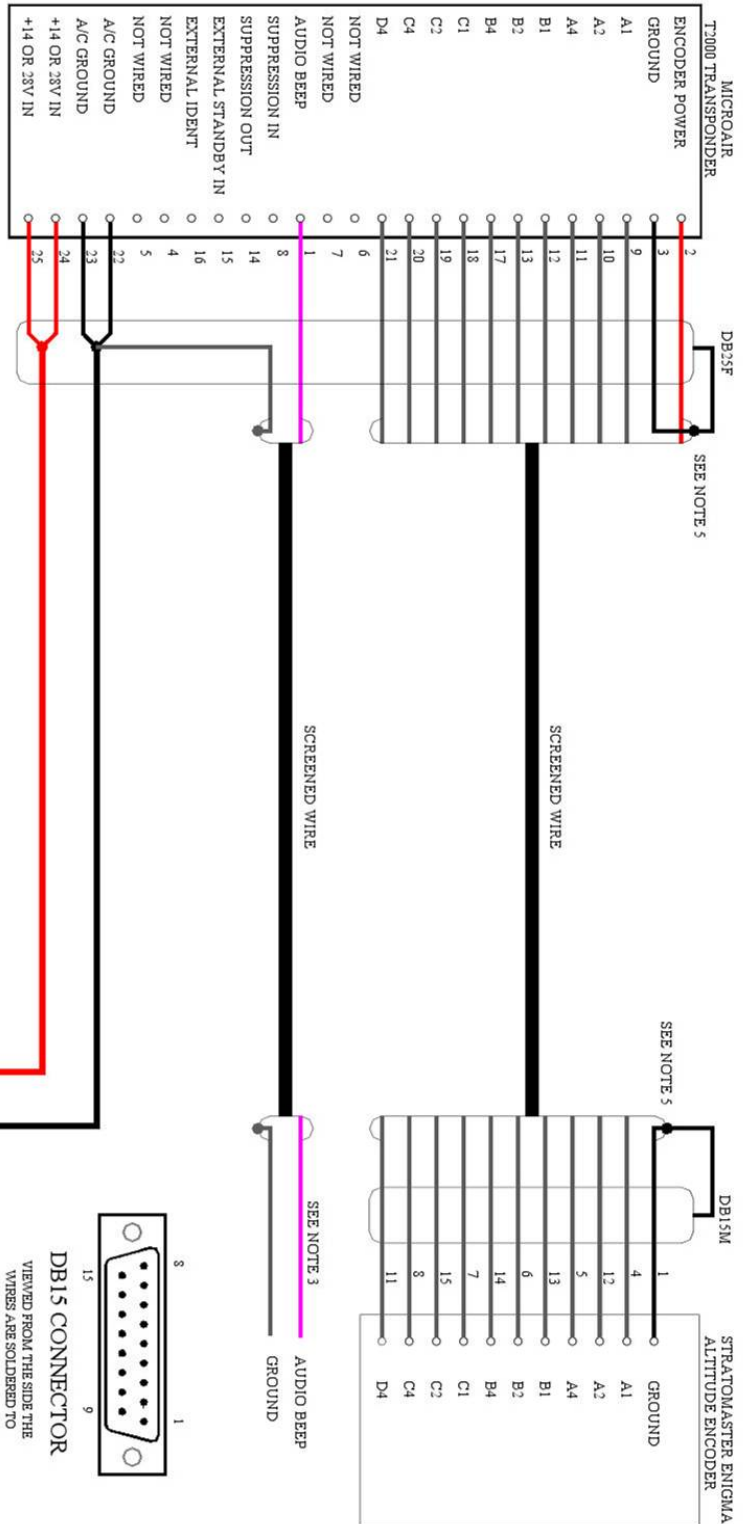

NOTES

1. +14 OR 28V POWER INPUT TO HAVE 5AMP MAXIMUM CIRCUIT BREAKER.
2. EXTERNAL IDENT SWITCH IF FITTED SHOULD BE MOMENTARY-ON TYPE
3. AUDIO BEEP LINE CAN BE TAKEN TO AN AUDIO PANEL OR DIRECTLY TO THE HEADPHONES, IF NOISE CAN BE HEARD WITH BEEP CONNECTED, INSTALL 1K RESISTOR IN SERIES.
4. THE ENCODER STROBE LINE SHOULD BE GROUNDED
5. SHIELD OF SCREENED WIRE TO BE STRAPPED TO BODY OF DB CONNECTOR.
6. HARNESS LENGTHS OF 600MM (+/- 25MM) ARE TO BE AVOIDED TO REDUCE THE INSTANCE OF RF INTERFERENCE FROM VHF RADIO.
7. THIS DIAGRAM IS APPLICABLE TO REVISIONS 5, 6, & 7.

MICROAIR T2000SFL - WIRING DIAGRAM WITH STRATOMASTER ENIGMA ENCODER

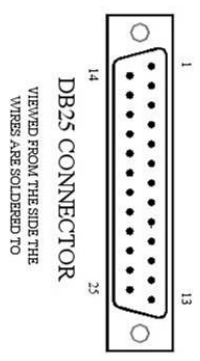

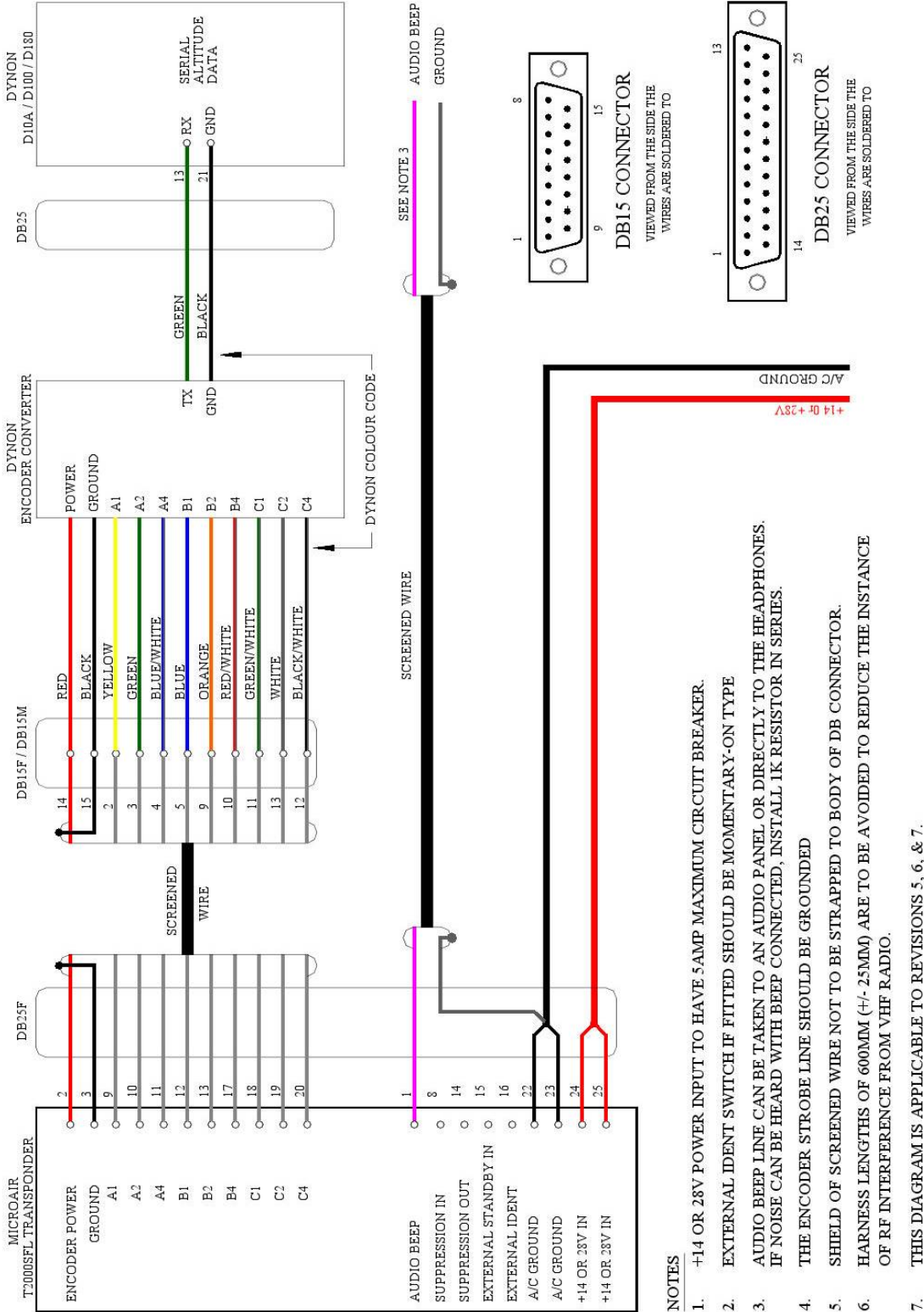

MICROAIR T2000SFL - WIRING DIAGRAM

WITH DYNON D10A / D100 / D180 ENCODERS

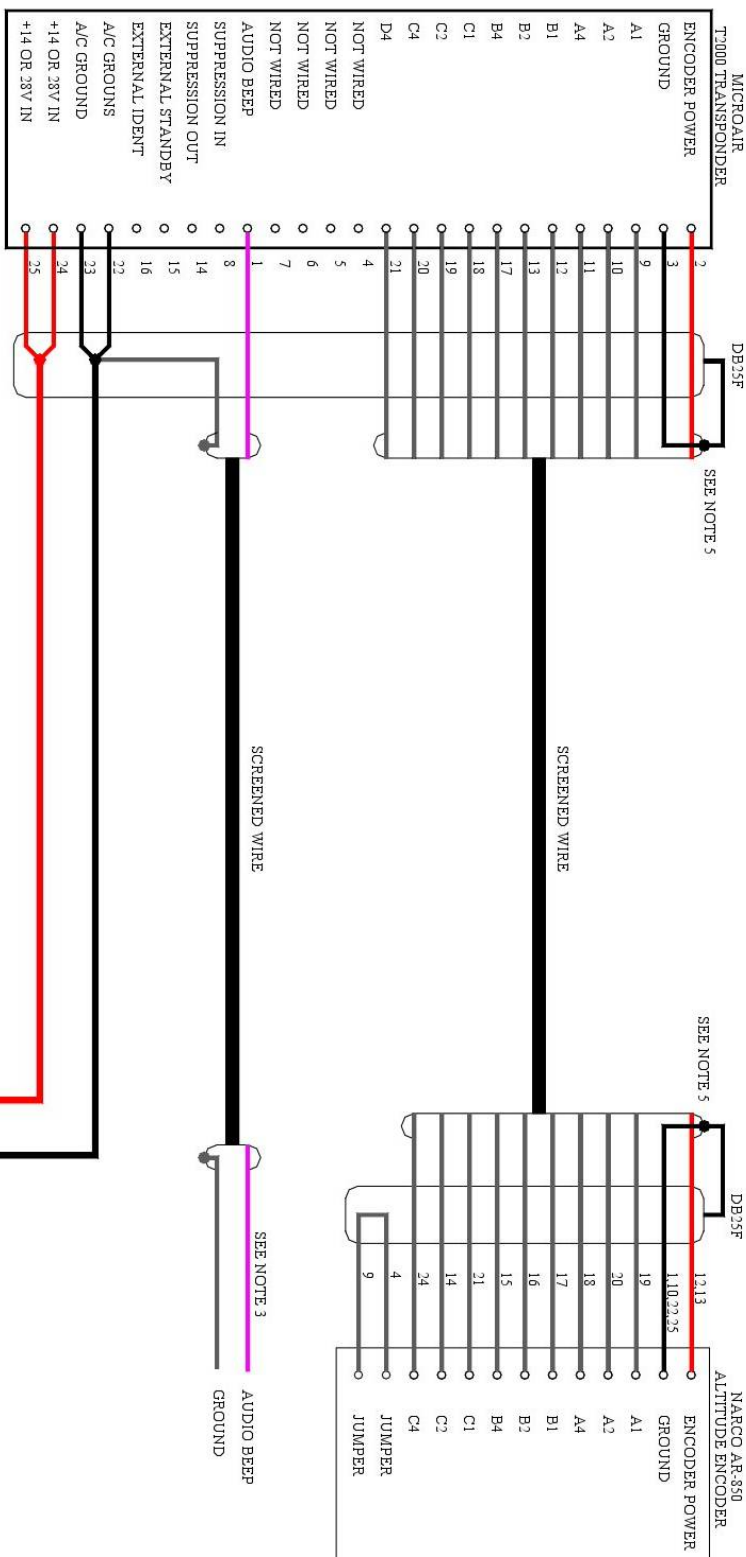

NOTES

1. +14 OR 28V POWER INPUT TO HAVE 5AMP MAXIMUM CIRCUIT BREAKER.
2. EXTERNAL IDENT SWITCH IF FITTED SHOULD BE MOMENTARY-ON TYPE
3. AUDIO BEEP LINE CAN BE TAKEN TO AN AUDIO PANEL OR DIRECTLY TO THE HEADPHONES. IF NOISE CAN BE HEARD WITH BEEP CONNECTED, INSTALL 1K RESISTOR IN SERIES.
4. THE ENCODER STROBE LINE SHOULD BE GROUNDED
5. SHIELD OF SCREENED WIRE TO BE STRAPPED TO BODY OF DB CONNECTOR.
6. HARNESS LENGTHS OF 600MM (+/- 25MM) ARE TO BE AVOIDED TO REDUCE THE INSTANCE OF RF INTERFERENCE FROM VHF RADIO.
7. THIS DIAGRAM IS APPLICABLE TO REVISIONS 5, 6, & 7.

+14 TO 28Vdc INPUT
A/C GROUND

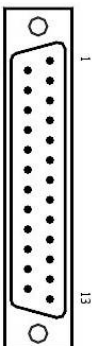

DB25 CONNECTOR
VIEWED FROM THE SIDE THE WIRES ARE SOLDERED TO

MICROAIR T2000SFL - WIRING DIAGRAM

WITH NARCO AR-850 ENCODER

9.0 INSTALLATION DIMENSIONS

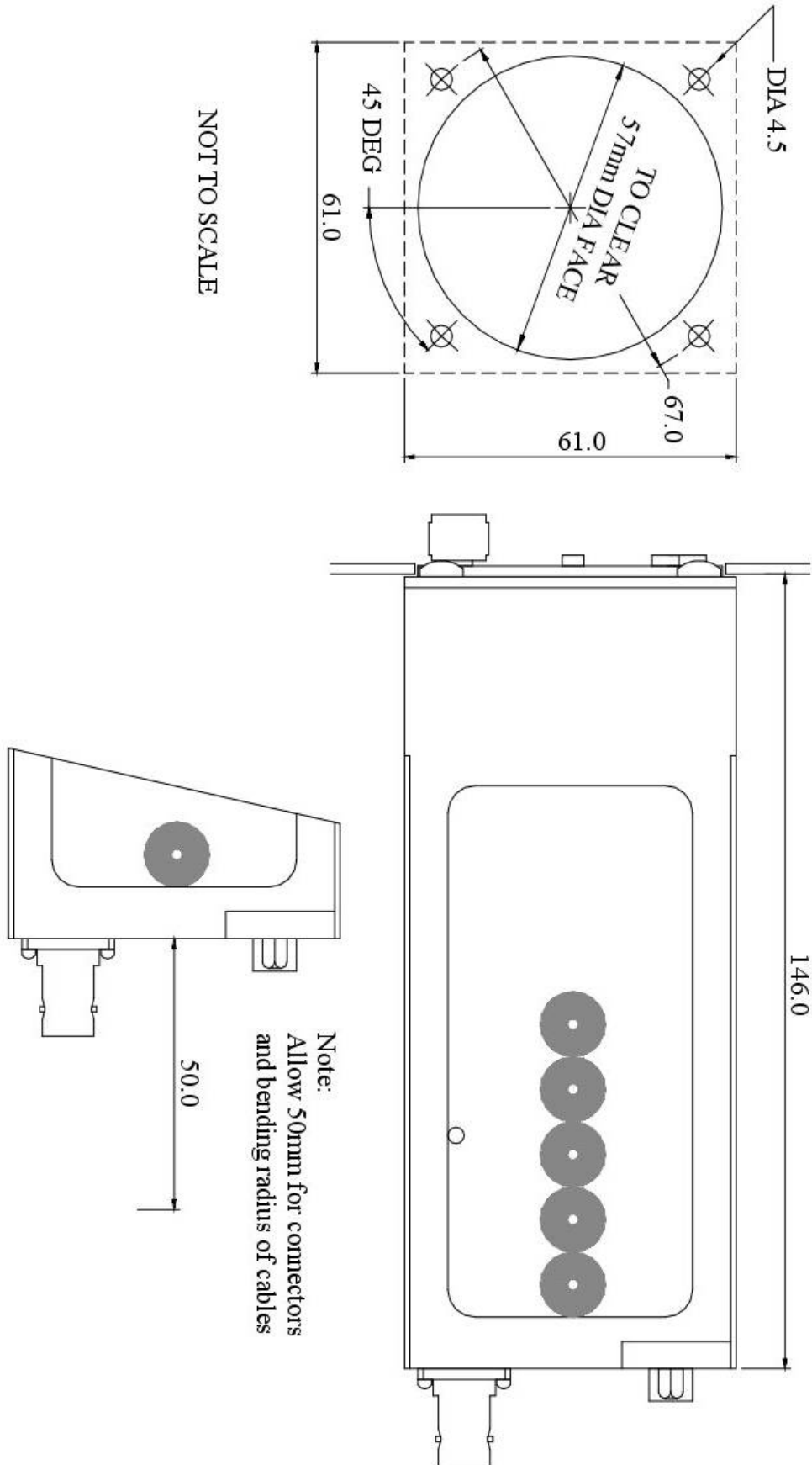

10.0 PIN ASSIGNMENTS

Pin	Assignment
1	BEEP AUDIO TONE
2	ENCODER SWITCHED POWER OUT (= A/C POWER)
3	GROUND
4	NOT WIRED
5	NOT WIRED
6	NOT WIRED
7	NOT WIRED
8	SUPPRESSION IN (5 TO 20V)
9	GILLHAM CODE A1
10	GILLHAM CODE A2
11	GILLHAM CODE A4
12	GILLHAM CODE B1
13	GILLHAM CODE B2
14	SUPPRESSION OUT (5V)
15	EXTERNAL STANDBY (GROUND TO OPERATE)
16	EXTERNAL IDENT (GROUND TO OPERATE)
17	GILLHAM CODE B4
18	GILLHAM CODE C1
19	GILLHAM CODE C2
20	GILLHAM CODE C4
21	GILLHAM CODE D4
22	A/C GROUND
23	A/C GROUND
24	A/C POWER (+10V TO +33V)
25	A/C POWER (+10V TO +33V)

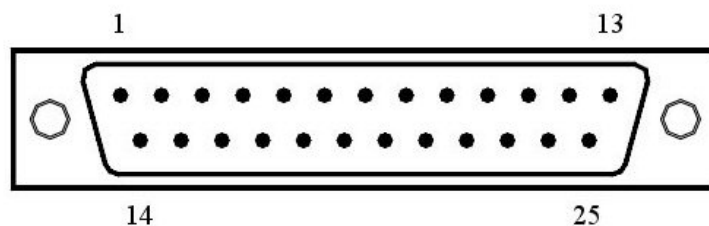

DB25 CONNECTOR

VIEWS FROM THE SIDE THE
WIRES ARE SOLDERED TO

11.0 PANEL TEMPLATE

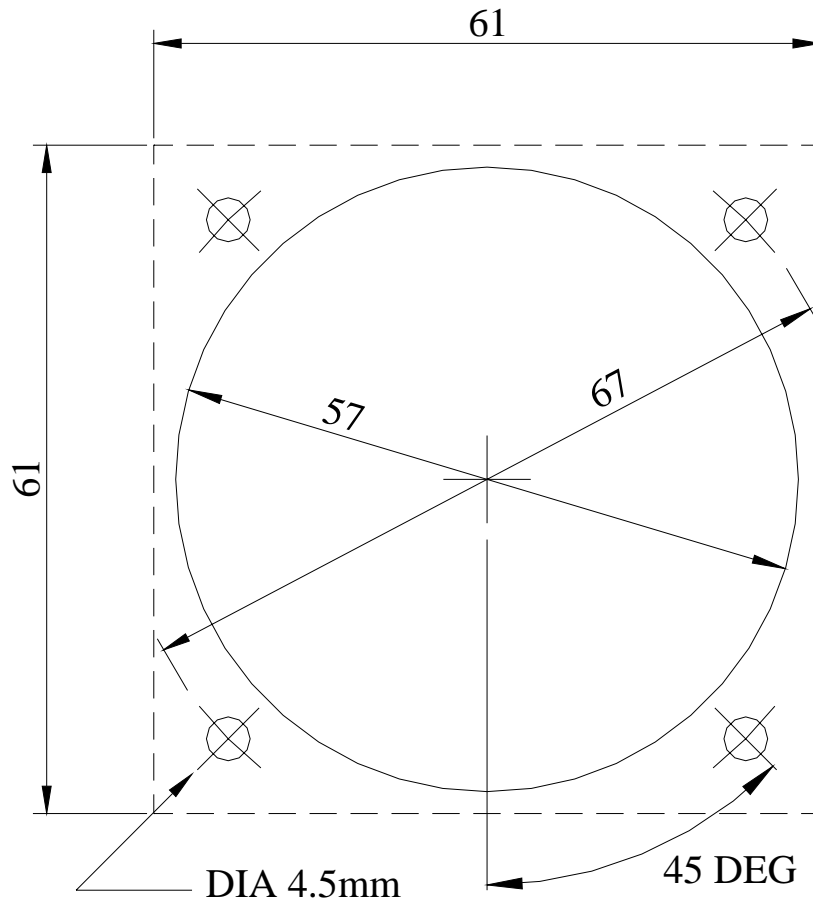

12.0 SPECIFICATIONS

ATSO Approval	1C74c
RTCA Compliance	DO-144 DO-160D DO-178B Level C
Transmitter	1090MHz +/-0.2MHz 200W Pulse Output 80nS Rise Time 120nS Fall Time
Receiver (1030MHz)	0 to -71dBm Dynamic Range 1030MHz Centre Frequency +/-5MHz Pass band
Input Power	10-33Vdc 100-150mA @ 28V 150-200mA @ 14V
Operational Modes	Standby Mode 3A Mode 3A/C Mode 3A/C with Altitude Displayed
Dimensions	Length 169mm (6.65") Width 61mm (2.40") Height 61mm (2.40")
Weight	600g (21 oz)
Features	Encoder Altitude Display Option Altitude Alert Voltage Monitoring and Alert Switched Encoder Power Output Suppression In / Out Remote Standby Switch Option Remote Ident Switch Option Audio Beep Alert Tone

13.0 WARRANTY CARD

Please complete and return the yellow warranty card to Microair Avionics. The warranty period is 12 months from the date of sale.



MICROAIR AVIONICS PTY LTD
 P O Box 5532
 Bundaberg QLD 4670
 AUSTRALIA
 Tel 07-41553048 INT ++61 7 41553048
 Fax 07-41553049 INT ++61 7 41553049
 Email sales@microair.com.au
 Web Site www.microair.com.au

WARRANTY REGISTRATION CARD

Complete the details on this form and return to our head office.

Microair Avionics
P O Box 5532
Bundaberg QLD 4670
AUSTRALIA

OWNER'S NAME	
ADDRESS	
CITY ZIP	STATE
COUNTRY	
MODEL NO NUMBER	SERIAL
DATE OF PURCHASE	

SUPPLIER	
ADDRESS	
CITY ZIP	STATE
COUNTRY	

To validate your warranty and assist Microair Avionics in providing you with better warranty service, fill in and return this warranty card.

You can alternately complete this warranty card on line at our web site (www.microair.com.au), and email it to us.

Thank you.

Microair Avionics will honour the warranty as twelve months from the date of installation where the installation was carried out by an approved shop, or the installation inspected and calibrated by a approved avionics shop. The warranty card must be signed and dated by the avionics shop.

An approved avionics shop is defined as a maintenance organisation which holds approvals from their National Aviation Authority (NAA) to install, calibrate, and maintain avionics equipment.

If you have misplaced the card, please use the warranty registration form on the Microair Avionics website www.microair.com.au.

For full details of the warranty please refer to the T2000SFL User Manual (inside rear cover).

