



Bob Nuckolls
AeroElectric Connection
6936 Bainbridge Road
Wichita, KS 67226-1006
Voice: 316-685-8617
Revision -D- 03/16/08

Low Cost Ground Power Jack for your Airplane.

The graceful alternative to jumper cables

Fitting your airplane with a ground power jack is a good idea . . . you can recharge a dead battery from outside the airplane . . . or crank the engine if the battery is too weak. The ground power jack is also useful during construction. Many an airplane coming down the assembly line gets electrical and avionics systems checkouts long before engines and batteries are installed and running. For many years, Piper has used a heavy duty truck power connector made by Cole-Hersey as their ground power jack of choice. It's lower in cost, smaller and easier to install than the 3-prong, military style jack used on most other airplanes. A number of readers have contacted me wondering how to mount the critter and how to attach a fat wire to the back side. It appears to be some sort of solder fixture for wire attachment - no threads or clamping device. I spent a couple of hours a few evenings ago developing the poor machinist's approach to modifying the "Piper" style jack for ease of installation on airplanes. You'll need a drill press (used to fixture the parts for soldering), hand held drill motor, belt or disk sander, a propane torch and a few parts from the hardware store. Here's one way to do it By the way, numbers in brackets [] refer to circled numbers in Figure 2.

(1) You'll need two sets of toilet-seat screws from a hardware store or plumbing shop (be sure to get "aircraft quality" toilet-seat screws - shouldn't cost more than \$100 a set!!!). These will be about 3" long, made of brass and come with nuts and washers. They'll be .312" coarse thread. You need the ones with very low profile heads. You'll also need two (.032 thick minimum) heavy brass washers [8] with .312" holes in them and an o.d. of .500 to .625".

(2) Fabricate a brass backing plate [4] from .032" or thicker brass sheet. This material can be purchased from most

hobby stores (put up in small sheets by KS Engineering). The dimensions of this part are not critical. The primary function is to conduct heavy current flows from one side of the ground power jack to the other via the mounting bolts on each side.

(3) Chuck one of the screws in a hand drill motor and spin the screw while holding the edge of the head against a belt or disk sander. Reduce the head diameter until it just slips into the center-terminal cavity of the ground power jack.

(4) Several of the following operations will cause the center-terminal of the ground power jack to get HOT. This will melt the plastic bumper found under the spring loaded lid, right on the end of the center-terminal. Grasp this bumper with a pair of pliers and remove it with a gentle twisting, pulling motion.

(5) Cut off the center-terminal just before the fillet starts as shown at [11]. Use disk or belt sander to remove additional material so that the cut is just flush with the first flange [12].

(6) Brighten up the head of your ground-off screw with steel wool. If the interior of the ground power jack center-terminal isn't bright and clean too, then do some work on it with the steel wool.

(7) Chuck the ground-off screw in a drill press and swing the drill press table so that it centers just inside one edge. Hold the ground power jack lid open and let it hang down the side of the table so that you can lower the ground-off screw into the center-terminal rear cavity. Apply sufficient pressure so that the ground power jack is captured between table and screw with the screw absolutely vertical with

respect to the face of the ground power jack.

(8) Use a propane torch or large electric soldering iron to heat the screw and center terminal and flow the cavity full of 60/40 or 63/37 electronic grade solder. Do this by feeding the solder in against the far side of the cavity [7] from where you are heating it. The solder will wick under the screw and flow toward the hotter side. Take care not to fill it TOO full.

(9) After the joint cools, use a coarse file if necessary to remove any solder that extends past your cut-off line [11]. When your terminals bolt up to this fitting, the brass washers [8] should be resting on the brass center-terminal, not on a mound of solder. You may also find that the phenolic back plates are loose with respect to the housing. You may wick some super glue into the gap between the phenolic and the housing. Capturing this material will be helpful when it's time to torque nut [9].

(10) You can now cut off bolt [10] so that it extends approximately .7" past the cutoff line [11]. Use the disk sander to deburr the end so that nuts will run freely onto the screw. Replace the plastic bumper removed in step 4.

(11) Some thoughts as to mounting location on the airplane - if your battery is on opposite side of cabin from engine, by all means, mount the jack as close as practical to the battery. Keeping wiring short is a virtue. If your battery is close to or inside the engine compartment, consider mounting the ground power jack more remote from the battery and taking the hit on 2AWG wire weight (4 oz per foot). When someone is tasked to disconnect your ground power jack with the engine running, it's a good idea keep that person away from the prop.

(12) The wiring diagram shows 4AWG wire for high current pathways . . . entirely adequate for situations where the ground power jack is mounted within a couple of feet of the battery. For more remote locations, use 2AWG wire.

(13) In plastic airplanes, two wires are necessary to complete the hot and ground-side connections. Metal airplanes MIGHT be able to use airframe ground . . . but if the structure where the jack is mounted consists mostly of sheet metal and associated stiffeners, consider adding a doubler plate to the skin to support the jack and add a 2AWG jumper from ground power jack mounting bolt to a major structural member. Ideally, the system should ground

at battery minus (-) terminal.

(14) Cut off and de-burr two more screws [3] with lengths appropriate to the installation. Cut hole in aircraft skin [2] to accommodate ground power jack installation. Install backing plate [4] with screws [3], thin washers that came with screws [5], and nuts [6]. If the installation is being made on a composite airplane, install ground lead for ground power jack under one washer [5] before final tightening.

(15) Attach "hot" lead to ground power jack by sandwiching its terminal lug between washers [8].

(16) Upon completion of your restricted fly-off period, check all three bolts for adequate torque before putting a tiny drop of super glue on the threads of each fastener, just beside the nut.

(17) The wiring described offers several noteworthy features:

---A diode across the ground power contactor prevents inductive arcing of the ground power switch. A diode in series prevents the contactor from being energized by reverse polarity power coming in from the outside.

---A press-to-test lamp fixture may be wired to permit the pilot to tell if ground power is applied. Pressing the fixture not only checks the bulb but it requires ground power to be on before the bulb will illuminate. This feature functions whether or not the ground power contactor is closed.

---A crowbar ov module will sense an externally applied over voltage and immediately open the ground power contactor by popping the switch-breaker. Crowbar ov modules were described in Sport Aviation for December 1993 and are available through B&C Specialties at <http://bandz.biz>

(18) FBOs with ground power facilities will have a plug that fits this jack. If your airplane is a 14-volt system, you should also consider cutting one end off of a set of automotive jumper cables and wiring it into a mating plug. Keep this jumper cable set handy for off-field assistance in battery charging or engine cranking with the aid of a 4-wheeled vehicle.

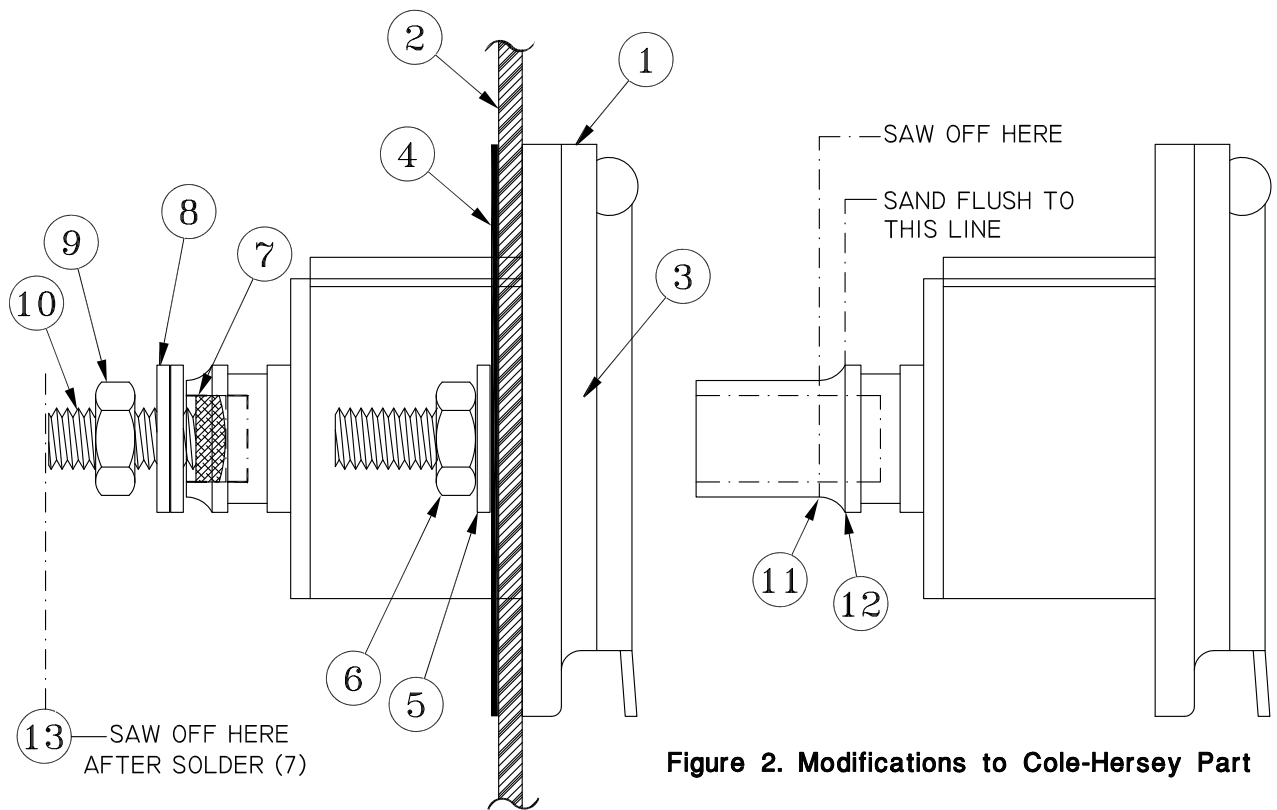
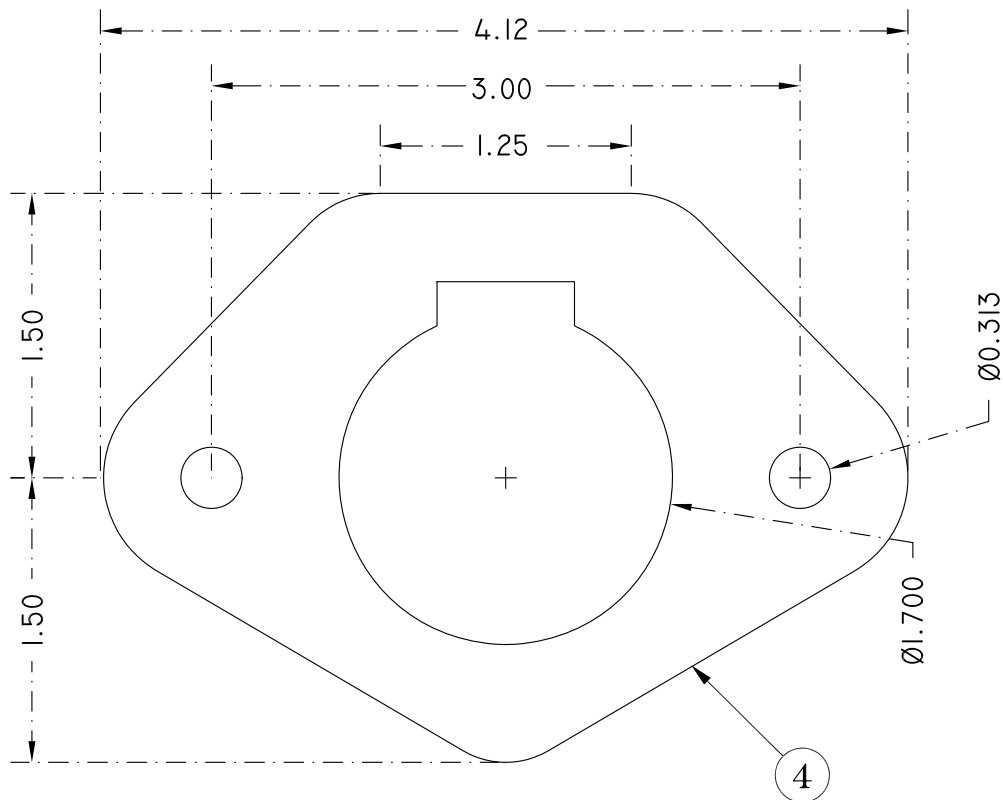

Figure 2. Modifications to Cole-Hersey Part



MATERIAL FOR BACKPLATE IS
0.032" MINIMUM THICK BRASS

Figure 1. Brass Backplate Fabrication

TITLE	PAGE
GROUND POWER	3.0

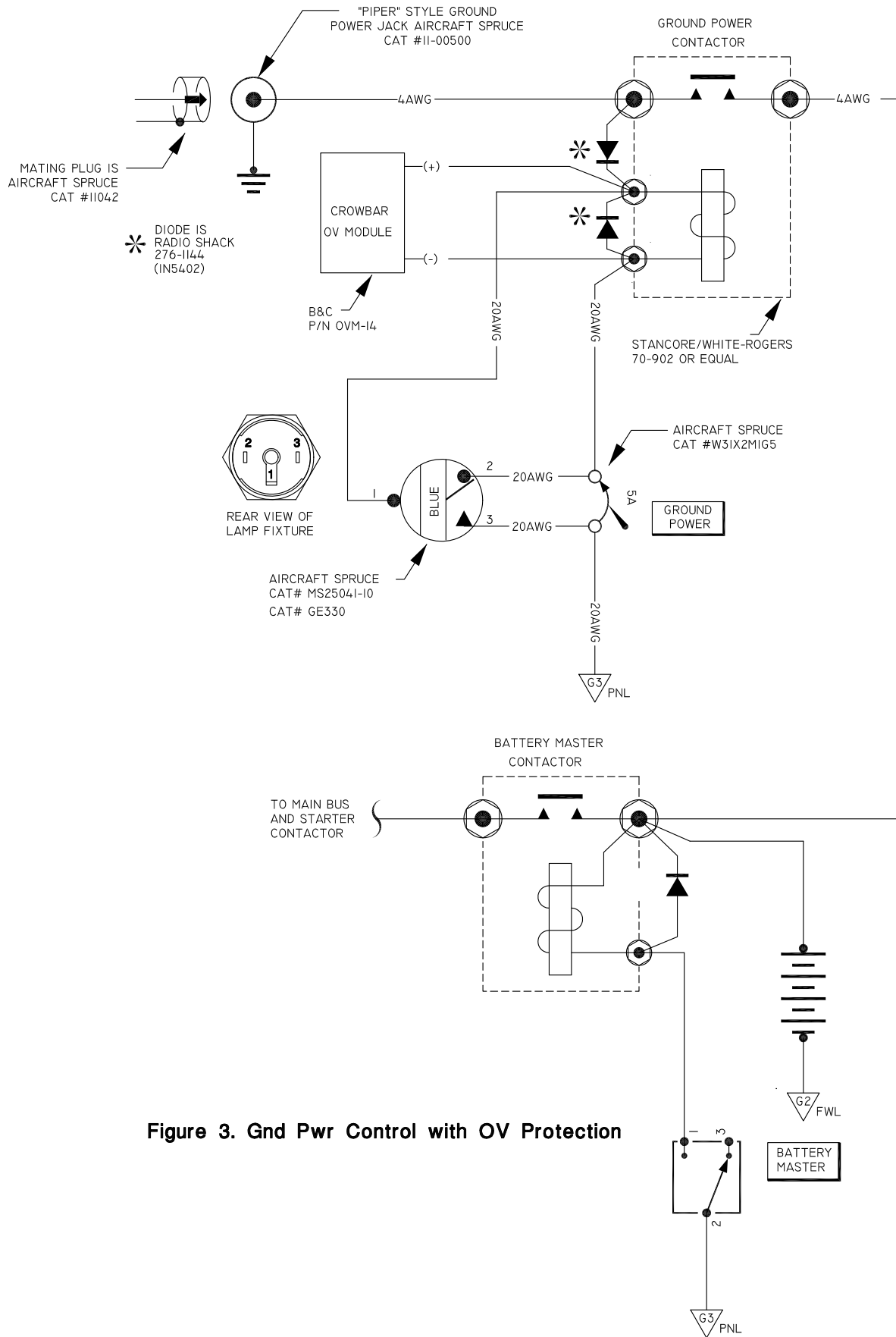

Figure 3. Gnd Pwr Control with OV Protection

TITLE	PAGE
GROUND POWER	4.0

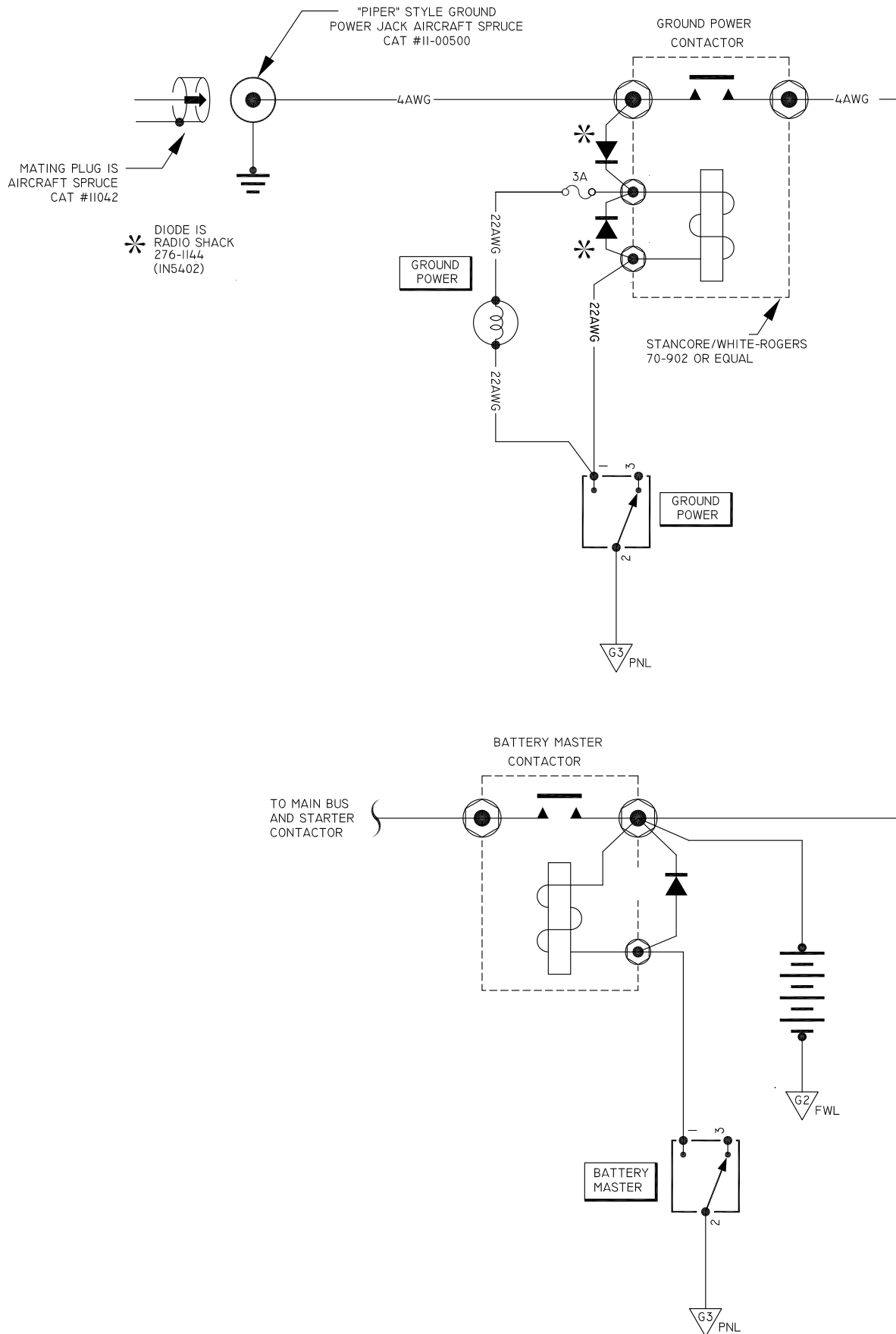

Figure 4. Gnd Pwr Control without OV Protection

TITLE	PAGE
GROUND POWER	5.0