

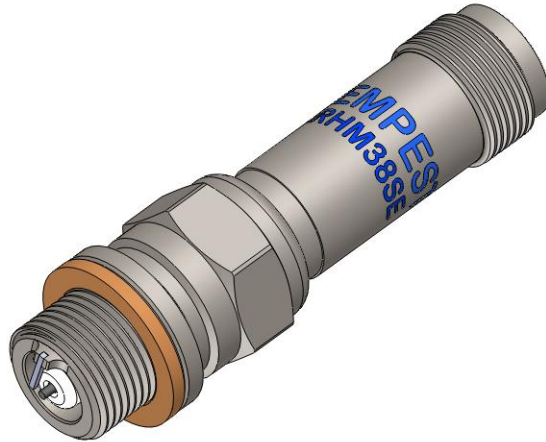

AVIATION SPARK PLUGS



1710A

Installation and Maintenance Manual Guidance

SCOPE:

This guidance provides details about the installation and maintenance of TEMPEST® Aviation Spark Plugs from Aero Accessories, Inc.

All reasonable attempts were made to make this manual as complete and accurate as possible. If you have any questions, comments, corrections, or require clarification of any information contained herein, please contact Aero Accessories, Inc. Customer service Department at:

Aero Accessories, Inc.
1240 Springwood Ave.
Gibsonville, NC 27249

Phone: (800) 822-3200
Fax: (336) 449-5461
customerservice@aeroaccessories.com

Consolidated Applications Data available by visiting www.tempestplus.com
Current FAA regulations allow qualified owners and operators of aircraft to perform certain types of preventative maintenance, including spark plug inspection, rotation and service. Consult the FAR's for details. In addition, if in doubt as to your qualifications an experienced aircraft technician with an A&P license is an excellent choice for conducting spark plug related maintenance.

ISSUED			REVISED		
MO	DAY	YEAR	MO	DAY	YEAR
02	10	2010	08	29	2012



PAGE NO.	REVISION
Cover	-C-

LOG OF REVISIONS

<u>Revision</u>	<u>Description</u>	<u>Page Revised</u>	<u>Date</u>
-O-	Initial Issue (Original)	N/A	03/31/2003
-A-	Added XL Premium Spark Plugs	All	01/15/2005
-B-	Edited to reflect Tempest and Aero Acquisition of product line, retyped and marketing information edited.	All	02/10/2010
-C-	Added resistance evaluation and cleaning information.	All	08/29/2012

ISSUED			REVISED		
MO	DAY	YEAR	MO	DAY	YEAR
02	10	2010	08	29	2012



PAGE NO.	REVISION
i	-C-

TABLE OF CONTENTS

0.0	INTRODUCTION.....	0-1
0.1	Copyright Statement.....	0-1
0.2	Notices.....	0-1
0.3	How To Use This Manual.....	0-2
0.4	Relevant Publications.....	0-2
0.5	Magneto Ignition System Overview.....	0-2
0.6	Maintenance Personnel.....	0-3
1.0	TECHNICAL REFERENCE.....	1-1
1.1	Description and Operation.....	1-1
1.2	Specifications.....	1-2
1.3	Selection Criteria.....	1-3
1.3.1	Reach.....	1-3
1.3.2	Heat Rating.....	1-3
1.3.3	Shielded Terminal Design.....	1-4
1.3.4	Plug Length.....	1-4
1.4	Spark Plug Tools.....	1-4
1.5	Spark Plug Parts.....	1-5
2.0	INSTALLATION PROCEDURES.....	2-1
2.1	Preinstallation.....	2-1
2.1.1	Copper Gaskets.....	2-1
2.1.2	Anti-Seize Compound.....	2-1
2.2	Installation.....	2-2
2.2.1	Correct Tools.....	2-2
2.2.2	Installation Procedures.....	2-2
2.2.3	Spark Plug Connector Installation.....	2-3
3.0	OPERATING SITUATIONS.....	3-1
3.1	Operating Period.....	3-1
3.2	Preignition.....	3-1
3.3	Detonation.....	3-1
3.4	Connector Well Arcing and Flashover.....	3-2
3.5	Improper Gaskets and Proper Selection of Spark Plugs.....	3-2
4.0	MAINTENANCE.....	4-1
4.1	Removal Procedures.....	4-1
4.1.1	Terminal Connectors.....	4-1
4.1.2	Spark Plug Handling.....	4-1
4.2	Troubleshooting – Electrode Conditions.....	4-2
4.2.1	Worn Electrodes.....	4-2
4.2.2	Carbon Fouling.....	4-4
4.2.3	Oil Fouling.....	4-4
4.2.4	Lead Fouling.....	4-4
4.2.5	Bridged Electrode Gaps.....	4-4
4.2.6	Cracked Core Nose.....	4-5
4.3	Reconditioning Service.....	4-5
4.3.1	Preliminary Visual Inspection.....	4-5
4.3.2	Degreasing.....	4-5
4.3.3	Resistance Evaluation.....	4-5
4.3.4	Cleaning The Firing and Barrel Ends.....	4-6
4.3.5	Cleaning The Terminal Well.....	4-9
4.3.6	Cleaning Connector Seats.....	4-9
4.3.7	Firing End Inspection.....	4-10
4.3.8	Cleaning The Threads.....	4-10
4.3.9	Gap Setting Procedures.....	4-10
4.3.10	Rotating Spark Plugs.....	4-11
4.3.11	Painting Spark Plugs.....	4-12
5.0	PRESERVATION AND STORAGE.....	5-1
6.0	WARRANTY.....	6-1
6.1	Warranty Period.....	6-1
6.2	Warranty Procedures.....	6-1

ISSUED			REVISED		
MO	DAY	YEAR	MO	DAY	YEAR
02	10	2010	08	29	2012



PAGE NO.	REVISION
ii	-C-

0.0 INTRODUCTION

0.1 COPYRIGHT STATEMENT

The information and designs contained in this document are proprietary to Aero Accessories, Inc. and will not, in whole or in part, be duplicated, disclosed, or used without written consent of Aero Accessories, Inc. This document is protected as an unpublished work under the U.S. copyright Act of 1976, as well as under all other pertinent domestic and international property provisions. All rights reserved.

0.2 NOTICES

WARNING: IMPROPER OR UNAUTHORIZED APPLICATIONS OF THE INFORMATION CONTAINED IN THIS MANUAL MAY RESULT IN LOSSES OR DAMAGES TO THE USER.

No liability will be assumed by Aero Accessories, Inc. for actual, consequential, or other types of damages directly or indirectly resulting from the unauthorized use of this manual for other than its stated purpose.

The accuracy and applicability of this manual has not been verified for any assembly, component, or part not manufactured by Aero Accessories, Inc. Any use of this manual for other than its intended purpose, or for performing any installation, maintenance, replacement, adjustment, inspection, or overhaul of any assembly, component, or part not manufactured by Aero Accessories, Inc. is not approved, endorsed, or sanctioned by Aero Accessories, Inc.

When performing installation, maintenance, replacement, adjustment, inspection, or overhaul of any Aero assembly, component, or part, it is imperative that the latest revision of the appropriate manual or product support document be referenced. Contact Aero Accessories, Inc. to be sure you have the latest manual or support document revision before performing any work. This manual is subject to change without notice.

Use of non-approved repair parts and tools may result in unit malfunction and/or affect equipment safety, and may be considered a violation of FAA repair guidelines.

All reasonable attempts were made to make this manual as complete and accurate as possible. If you have any questions, comments, corrections, or require clarification of any information contained herein, please write Aero Accessories, Inc. Customer service Department at:

Aero Accessories, Inc.
1240 Springwood Ave.
Gibsonville, NC 27249

Or call or email Aero Accessories, Inc. Product Support Department at:
Phone: (800) 822-3200
Fax: (336) 449-5461

ISSUED			REVISED		
MO	DAY	YEAR	MO	DAY	YEAR
02	10	2010	08	29	2012



PAGE NO.	REVISION
0-1	-C-

0.3 HOW TO USE THIS MANUAL

This document contains necessary information relating to the ownership of Tempest® Aviation Spark Plugs manufactured by Aero Accessories, Inc.

Section 1 describes the Tempest® Aviation Spark Plugs.

Section 2 includes detailed procedures for installation.

Section 3 and **4** describes operation and maintenance procedures respectively.

Section 5 describes procedures used to preserve and store Tempest® Aviation Spark Plugs.

Section 6 describes Tempest® Aviation Spark Plugs warranty and procedures.

0.4 RELEVANT PUBLICATIONS

Engine Manufacturer's Service Manual
Consolidated Applications Data available on Tempest® web site

0.5 MAGNETO IGNITION SYSTEM OVERVIEW

Aero Accessories, Inc. is an innovative leader in the design and manufacture of aircraft components and systems.

A. Worldwide Network

TEMPEST® Products are available through an international network of aircraft parts distributors that offer outstanding product support, prompt delivery, and friendly customer service. See TEMPEST® Authorized Distributor List, or visit the Tempest® web site at www.tempestplus.com for a listing of the TEMPEST® distributor nearest you.

B. AOG and Emergency Orders

Authorized distributors of TEMPEST® Products are required to carry inventory sufficient to satisfy market requirements including AOG needs.

C. An offering of TEMPEST® Products are available in the following:

- Slick and Bendix magneto replacement parts and kits.
- TEMPEST® Aviation Spark Plugs: Aero Accessories manufactures massive electrode as well as fine wire plugs for almost every General Aviation aircraft and engine. TEMPEST® Aviation Spark Plugs can be conveniently purchased in boxes of 12, 4 or individually (check with a TEMPEST® distributor). TEMPEST® part numbering is easy. Part numbers for TEMPEST® Aviation Spark Plugs look similar to the part numbers that some aviation consumers have memorized due to a lack of choice. For TEMPEST® Aviation Spark Plugs, just add a "U" to the front of the competing brand's part number (for instance, one of Aero's most popular TEMPEST® Aviation Spark Plugs is UREM40E, which, from a part number perspective, looks very similar to REM40E, a competing part number).

ISSUED			REVISED		
MO	DAY	YEAR	MO	DAY	YEAR
02	10	2010	08	29	2012



PAGE NO.	REVISION
0-2	-C-

Refer to TEMPEST® consolidated Application Data publication for the approved TEMPEST® Aviation Spark Plug part number for a particular application. TEMPEST® Aviation Spark Plugs are FAA-PMA approved.

- Tools: To support the aforementioned products, Aero Accessories also offers Aero designed, manufactured, and marketed tools. For more information on tools and other Aero Accessories products visit the www.tempestplus.com web site.

0.6 MAINTENANCE PERSONNEL

Current FAA regulations allow qualified owners and operators of aircraft to perform certain types of preventative maintenance including spark plug inspection, rotation and service. Consult the FAR's for details. In addition, if in doubt as to your qualifications, an experienced aircraft technician with an A&P license is an excellent choice for conducting spark plug related maintenance.

ISSUED			REVISED		
MO	DAY	YEAR	MO	DAY	YEAR
02	10	2010	08	29	2012



PAGE NO.	REVISION
0-3	-C-

1.0 TECHNICAL REFERENCE

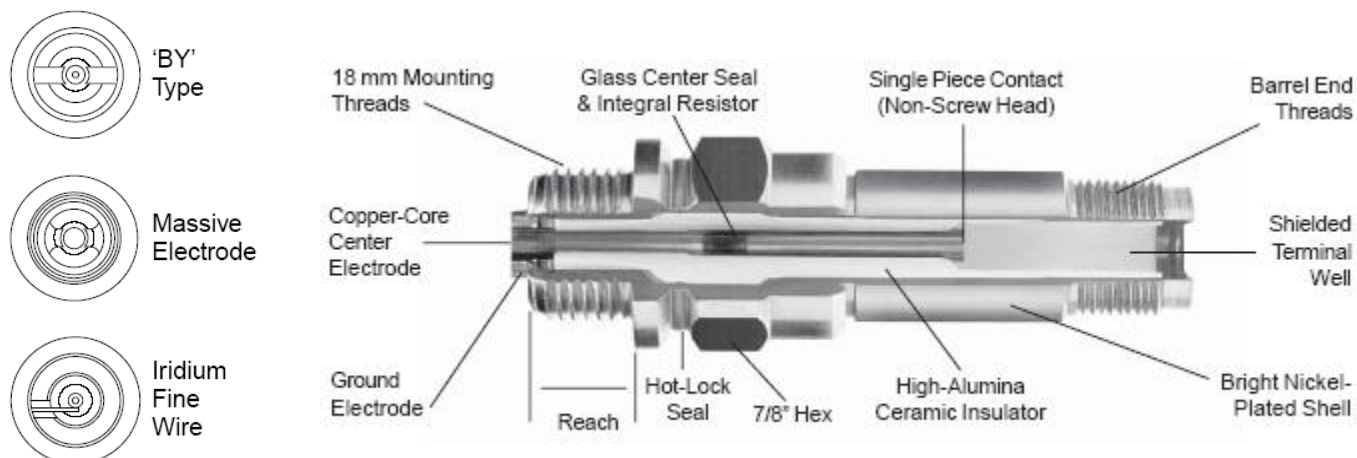

Figure 1-1

1.1 Description & Operation

The spark plug is the last component in the ignition circuit. It converts the magneto output into a high voltage spark that ignites the air-fuel mixture within each cylinder of a piston engine.

TEMPEST[®] Aviation Spark Plugs, available in both **massive electrode** and **fine wire** designs, offer superior heat transfer and leakage protection, advanced reliability, long life, and maximum cost effectiveness with the following design features:

- **High-conductivity copper core electrode** – is co-extruded inside a special nickel alloy for optimum heat transfer and resistance to combustion gases.
- **High-alumina ceramic insulator** – is enhanced with a proprietary glaze material to ensure the high mechanical strength and superior dielectric quality needed to survive the severe engine environment.
- **Iridium Fine Wire Electrode** – made from a high performance precious metal. The center electrode is robotically placed and controlled to ensure extra long life and superior performance.
- **Vacuum-cemented center electrode (Massive Electrode Only)** – protects the nickel alloy from corrosion and oxidation, provides consistent and even heat dissipation from the center electrode to the insulator.
- **Hot-lock assembly procedure** – resists the high pressure of combustion gases, and creates a zero-leakage seal between the insulator and outer shell.

ISSUED			REVISED		
MO	DAY	YEAR	MO	DAY	YEAR
02	10	2010	08	29	2012

- **Proprietary glass center seal and integral resistor** – bonds the insulator, center electrode and terminal into a single, zero-leakage structure for maximum durability and improved spark gap life.
- **Bright nickel plating** – provides corrosion protection in the severe environments of General Aviation.
- **Non-screw head contact** – offers a smooth and uninterrupted contact surface, more resistant to arcing and the resultant loss in energy transfer.
- **Projected Gap Design** – A projected gap design (massive electrode spark plug number UREM37BY and TEMPEST® fine wire Aviation Spark Plugs) and a large shell bore provide maximum circulation of combustion gases to scavenge lead deposits and burn off carbon deposits, resulting in better performance and longer life.

1.2 SPECIFICATIONS

TEMPEST® Part Number	Reach	Connector Thread	Electrode Type
URHB32E	13/16"	3/4" - 20	Massive
URHB32S	13/16"	3/4" - 20	Fine Wire
UREB36S	13/16"	5/8" - 24	Fine Wire
URHB36S	13/16"	3/4" - 20	Fine Wire
UREB37E	13/16"	5/8" - 24	Massive
URHB37E	13/16"	3/4" - 20	Massive
UREM37BY	1/2"	5/8" - 24	Massive
UREM38E	1/2"	5/8" - 24	Massive
URHM38E	1/2"	3/4" - 20	Massive
UREM38S	1/2"	5/8" - 24	Fine Wire
URHM38S	1/2"	3/4" - 20	Fine Wire
UREM40E	1/2"	5/8" - 24	Massive
URHM40E	1/2"	3/4" - 20	Massive
UREM42E	1/2"	5/8" - 24	Massive
URHM42E	1/2"	3/4" - 20	Massive

Note: All TEMPEST® Aviation Spark Plugs are available in an 18mm mounting thread size. The TEMPEST® massive electrode gap is .016" to .021". TEMPEST® fine wire plug gaps are .017" to .021".

ISSUED			REVISED		
MO	DAY	YEAR	MO	DAY	YEAR
02	10	2010	08	29	2012



PAGE NO.	REVISION
1-2	-C-

1.3 SELECTION CRITERIA

Spark plugs are available in different thread sizes and heat ranges.

The various sizes and heat ranges are needed to match engine requirements.

TEMPEST® Aviation Spark Plugs meet the necessary requirements for military and commercial applications. Plugs are designed to meet specifications for heat rating, reach, thread size, terminal connectors and shielding.

For information on which TEMPEST® Aviation Spark Plug is designed for your needs, refer to: Engine manufacturer's information and/or TEMPEST® website at www.tempestplus.com

1.3.1 REACH

The reach of a spark plug is measured from the shell gasket seat to the end of the threads. Correct reach is necessary to ensure the electrodes are positioned properly to ignite the fuel-air mixture and ensure consistent firings.

1.3.2 HEAT RATING

The heat rating of a plug measures the ability of a spark plug to transfer heat from the spark electrodes and insulator nose to the cylinder and engine cooling system while resisting carbon fouling. TEMPEST® Aviation Spark Plugs are available in a range of heat ratings to meet various engine and operational requirements. The use of terms "hot" or "cold" in reference to spark plugs is often a source of confusion when selecting the proper spark plug for an application. For a given engine series, hot plugs are usually specified for the lower horsepower engines and cold plugs for the higher horsepower engines. The terms actually refer to the plug's ability to dissipate heat. By definition, a cold heat range plug dissipates heat more rapidly. Likewise, a hot heat range plug has a slower rate of heat dissipation. The primary factor in whether a plug is hot or cold is the length of the insulator assembly core nose. Hot plugs have relatively long insulator noses and, therefore, a long heat transfer path. Cold plugs have relatively short noses and thus transfer heat more quickly. All other parts of a part number being equal, you can tell if an TEMPEST® Aviation Spark Plug is hotter or colder heat range by the numbers in the middle of the part number. For instance, comparing a UREM40E with a UREM38E, the UREM40E is a hotter plug because "40" is larger than "38".

ISSUED			REVISED		
MO	DAY	YEAR	MO	DAY	YEAR
02	10	2010	08	29	2012



PAGE NO.	REVISION
1-3	-C-

1.3.3 SHIELDED TERMINAL DESIGN

A shielded terminal design is used to prevent radio interference from the engine ignition system. TEMPEST® Aviation Spark Plugs are manufactured with either the 3/4" – 20 thread design or the 5/8" – 24 thread design.

1.3.4 PLUG LENGTH

Aero Accessories has shortened the overall length of some TEMPEST® Aviation Spark Plugs to provide greater clearance between the spark plug terminal well and engine cowling (check with TEMPEST® Aviation Spark Plug distributors for part numbers available in the new shorter length). The new shorter design does not alter spark plug performance.

1.4 SPARK PLUG TOOLS

Aero Accessories offers the following line of tools to support aviation spark plug maintenance activities:

Part Number	Description
AA-446™	Spark Plug Tray
T245™	Spark Plug Erosion Gage
T550-10™	Spark Plug Cleaning Tool (bag of 10)
T551™	Spark Plug Cleaning and Tester Unit (115 VAC)
T552™	Spark Plug Cleaning and Tester Unit (220 VAC)
T554™	Aircraft Spark Plug Feeler Gage
T555™	Spark Plug Hole Thread Chaser
T556™	Spark Plug Thread Lubricant (anti-seize)
T557™	Spark Plug Deep-Socket (3/8" Drive) 7/8" Hex Socket, 3 1/2" Overall Length, No Magnet
T557-1™	Spark Plug Deep-Socket (3/8" Drive) 7/8" Hex Socket, 3 1/2" Overall Length, With Magnet
T558™	Spark Plug Deep-Socket (1/2" Drive) 7/8" Hex Socket, 3 1/2" Overall Length, No Magnet
T559™	Spark Plug Vibrator Cleaner
T560™	Spark Plug Cleaner
T570™	Spark Plug Tool Kit (contains T240, T245, T550-10, T554, T555, T557, T559, T560, at a discount)
T571™	Time Rite Kit (18mm)
T572™	Time Rite Kit (14mm)
AT5K™	Automatic Spark Plug Resistance Tester

ISSUED			REVISED		
MO	DAY	YEAR	MO	DAY	YEAR
02	10	2010	08	29	2012



PAGE NO.	REVISION
1-4	-C-

1.5 SPARK PLUG PARTS

Aero Accessories currently offers copper mounting gaskets in bags of 100 (TEMPEST® part number UM-674PK) for TEMPEST® Aviation Spark Plugs or competing brands. Always use new spark plug gasket (UM-674) when installing a new plug or re-installing a reconditioned plug.

ISSUED			REVISED		
MO	DAY	YEAR	MO	DAY	YEAR
02	10	2010	08	29	2012



PAGE NO.	REVISION
1-5	-C-

2.0 INSTALLATION PROCEDURES

2.1 PREINSTALLATION

CAUTION: Ensure that the spark plug being installed is approved for your engine application. Long reach plugs should only be installed in cylinders designed for long reach plugs. Short reach plugs should only be installed in cylinders designed for short reach plugs.

CAUTION: Never install a spark plug that has been dropped (even if there is no visible sign of damage). Dispose of the dropped spark plug and replace it with a new TEMPEST® Aviation Spark Plug.

NOTE: All TEMPEST® Aviation Spark Plugs have been pre-gapped at the factory. However, it is good practice to check gap settings prior to installation.

Visually inspect all spark plugs prior to installation. Check firing and terminal ends for insulator cracks, deposits and contamination.

2.1.1 COPPER GASKETS

Always install new TEMPEST® Aviation Spark Plug with a new copper mounting gasket (TEMPEST® part number UM-674). The gasket provides a seal between the spark plug and the engine mounting surface. Each new TEMPEST® Aviation Spark Plug comes with one copper mounting gasket.

NOTE: TEMPEST® recommends replacing the copper mounting gasket every time the spark plug is removed from the engine. Only one copper mounting gasket per spark plug should be installed. If a thermocouple gasket is used, do not install a copper mounting gasket.

2.1.2 ANTI-SEIZE COMPOUND

NOTE: A clean, dry connection is recommended. However, if the use of a thread lubricant is desired, use an anti-seize compound recommended by the engine manufacturer or spark plug manufacturer.

Wire-brush the engine end threads to remove carbon and grime. Don't hit the electrodes or insulator with the wire brush. Then apply a thin coating of TEMPEST® T556™ spark plug thread lubricant to the engine end threads.

T556™ is an advanced product. It flows smoothly and dries quickly. It doesn't bead up like some other brands do. Don't get it on the electrodes or the insulator. If you do, wipe it off with a cloth dampened with water. Make sure the top sides (side away from the engine) of the threads are well coated. That's the side of the thread that will take the load when the sparkplug is tightened. Let the **T556™** dry. **NEVER APPLY ANTI-SEIZE COMPOUND TO THE HARNESS CONNECTOR THREADS.**

ISSUED			REVISED		
MO	DAY	YEAR	MO	DAY	YEAR
02	10	2010	08	29	2012



PAGE NO.	REVISION
2-1	-C-

2.2 INSTALLATION

2.2.1 CORRECT TOOLS

CAUTION: Use the proper tools for spark plug installation to prevent thread damage, cracked insulators and misfires.

A six point socket (TEMPEST[®] part number T557[™], T557-1[™] or T558[™]) may be used for proper installation. A twelve point socket may contact the connector threads and cause damage.

2.2.2 INSTALLATION PROCEDURES

NOTE: Make sure the spark plug and cylinder head threads are clean.

Hand – turn the spark plug to within one or two threads of the copper mounting gasket (TEMPEST[®] part number UM-674). If the plug doesn't turn easily, the cylinder threads may need to be cleaned. Use a T555[™] (or equivalent) spark plug thread cleaning tool to remove deposits from the cylinder head threads until hand tightening is possible to within one or two threads of tight.

CAUTION: Make sure side-loads are not applied to the spark plug. Side loading can crack the spark plug insulator.

Use a T557[™], T557-1[™] or T558[™] (or equivalent) 6 point, deep socket wrench with a torque indicator handle to tighten the plugs to the torque limits specified by the engine manufacturer.

Avoid over tightening.

NOTE: The table below applies to 18mm spark plugs and is provided as a general guideline only. Follow the engine manufacturer's recommendations for specific engine models.

Engine Manufacturer	Torque Reference		
	Foot Pounds	Inch Pounds	Newton Meters
Textron Lycoming	30 - 35	360 - 420	41 - 47
TCM	25 - 30	300 -360	34 - 41
Pratt & Whitney	25 - 30	300 -360	34 - 41
Wright Aeronautical	35 - 40	420 - 480	47 - 54
Franklin Engine Co.	25 - 30	300 -360	34 - 41

ISSUED			REVISED		
MO	DAY	YEAR	MO	DAY	YEAR
02	10	2010	08	29	2012



PAGE NO.	REVISION
2-2	-C-

2.2.3 SPARK PLUG AND IGNITION HARNESS CONNECTOR INSTALLATION

NOTE: Keep all parts clean and dry. Always handle terminal sleeves with clean, dry hands.

Wipe the connector clean with a lint-free cloth moistened with a quick evaporating solution such as acetone; lacquer thinner, wood alcohol or similar solvent.

Inspect the terminal assembly and replace those with any signs of mechanical failure.

Visually inspect the inside of the spark shielding barrel. It should be clean and dry and no cracks should be evident.

CAUTION: Be careful not to touch the spark plug connector or harness spring with your fingers. Residual contamination could cause arcing in the terminal well and a resulting misfire.

Insert the harness assembly in a straight line with the spark plug and finger tighten the connector nut.

CAUTION: To avoid damaged threads or cracked barrels, avoid excessive side-loading and do not over tighten.

Use an open-end wrench to hold the 7/8" hex plug nut (do not allow to turn), while tightening the lead terminal nut. For proper torque, refer to the harness manufacturer's recommendations.

ISSUED			REVISED		
MO	DAY	YEAR	MO	DAY	YEAR
02	10	2010	08	29	2012



PAGE NO.	REVISION
2-3	-C-

3.0 OPERATING SITUATIONS

3.1 OPERATING PERIOD

One of the most economical ways to maintain an efficient engine and avoid wasting fuel is to change spark plugs at regular intervals. As spark plug electrodes wear the voltage required to jump the gap increases. Under heavy loads misfires can occur, resulting in higher fuel consumption. Also a rich fuel mixture or poor oil control can foul or coat the ceramic insulator on the spark plug tip. Fouling, like excessive wear, will promote misfires and can eventually cause the spark plug to stop functioning. Maintaining correct spark plug gaps and removing deposits prevents engine misfires and ensures optimum performance. It is recommended that the internal resistance of the center electrode be checked during regular maintenance. If the resistance exceeds 5000 ohms, the spark plug should be replaced.

Since operating periods are dependent upon engine manufacturer's gap width recommendations, operating conditions, and deterioration of magneto components and ignition harnesses, service intervals may vary. The individual operator should determine the inspection and service interval based on past engine model experience, engine manufacturer guidelines, and FAA requirements.

3.2 PREIGNITION

Preignition is caused when the combustion charge is ignited prior to the normal, timed spark. This may be caused by a hot spot due to an overheated spark plug. Serious damage to the engine may result. Indicators include a rapid rise in the cylinder head temperature or engine roughness. If preignition is suspected, remove all spark plugs and inspect for damage (excessive wear, electrode crack or insulator nose irregularities). Follow the engine manufacturer's recommendations for correction procedures.

3.3 DETONATION

Detonation is an explosion of the combustion charge in an uncontrolled sudden manner. This condition may damage the spark plug electrodes or crack the insulator nose as well as destroy the engine if permitted to continue. Indications include a mildly rough engine, coupled with a knocking sound. If detonation is suspected, remove and inspect the spark plugs and follow the engine manufacturer's recommendations for correction procedures.

ISSUED			REVISED		
MO	DAY	YEAR	MO	DAY	YEAR
02	10	2010	08	29	2012



PAGE NO.	REVISION
3-1	-C-

3.4 CONNECTOR WELL ARCING AND FLASHOVER

When the terminal well of a spark plug becomes dirty with moisture or foreign matter terminal arcing and flashover may occur. Flashover is the unintended arc of the ignition discharge along the dirty terminal well or lead insulator to the shell. Flashover may lead to erratic misfiring, causing difficult engine starts, and rough running.

The best practice to avoid flashover is preventive maintenance. Spark plugs with dirty terminal wells should be replaced with new or reconditioned spark plugs, as should dirty leads.

Clean inside the lead well with lacquer thinner, similar solvent, or Bon Ami™ on a Q-Tip™. Use soapy water to remove the cleaning residue. Rinse the spark plug thoroughly. Washing with water won't hurt a **TEMPEST**® spark plug. The sealed resistor won't let water in. Blow the spark plug dry with low pressure compressed air.

Also, clean and inspect ignition harness connector terminals and seal grommets to prevent moisture entry.

3.5 IMPROPER GASKETS AND PROPER SELECTION OF SPARK PLUG

Copper mounting gaskets (TEMPEST® part number UM-674) are engineered to ensure proper sealing and firing tip location of a TEMPEST® Aviation Spark Plug. Aero Accessories recommends that a new copper gasket be used every time a spark plug is removed. Only one gasket per plug should be used.

With correct installation, the firing end of the plug is flush with the combustion chamber wall. This prevents threads from being exposed to combustion gases and developing hot spots which may lead to preignition. To ensure the firing end of the spark plug is flush with the combustion chamber wall always install a long reach plug in a cylinder designed for long reach plugs and a short reach plug in a cylinder designed for short reach plugs.

A gas leak at the gasket interface may cause higher-than-normal operating temperatures, again possibly leading to preignition. Prevent this possibility by using a new copper mounting gasket each time the spark plug is removed.

ISSUED			REVISED		
MO	DAY	YEAR	MO	DAY	YEAR
02	10	2010	08	29	2012



PAGE NO.	REVISION
3-2	-C-

4.0 MAINTENANCE

Proper maintenance is essential to extending spark plug life. Careful reconditioning allows spark plugs to be reused at a far lower cost than replacement. Adhere to a scheduled service interval as recommended by the engine manufacturer, FAA requirements or more stringent intervals based on operating conditions and personal experience with the engine type.

NOTE: Spark plug gap and deposit conditions should be closely monitored for optimum performance.

4.1 REMOVAL PROCEDURES

Prior to removing spark plugs for inspection and servicing, examine the area surrounding each spark plug. Parts that are damaged or may be missing can deteriorate ignition lead performance and overheat the spark plugs. Repair or replace parts as necessary.

4.1.1 TERMINAL CONNECTORS

Use an open-end wrench to hold the 7/8" hex plug nut (do not allow it to turn), while loosening the lead terminal nut with an appropriately sized open-end wrench.

To avoid twisting the lead, continue to use an open-end wrench to hold the 7/8" hex plug nut (do not allow it to turn), while unscrewing the lead terminal nut by hand.

Carefully pull the lead connector straight out. Avoid side pressure, which may damage the terminal sleeve or the barrel insulator.

Examine the terminal well insulator and replace it if cracked, arc tracked or otherwise damaged. Also visually inspect the contact and ignition lead terminal for evidence of arcing or other damage.

4.1.2 SPARK PLUG HANDLING

Remove each spark plug with an appropriately sized six point deep socket wrench (TEMPEST® part number T557™, T557-1™ or T558™ or equivalent). Carefully seat the wrench securely on the plug to avoid damage to the threads or barrel. Be sure to remove the gasket with each spark plug.

Identify each spark plug by engine cylinder and position (top or bottom) and place in the spark plug tray (TEMPEST® part number AA-446™). This pre-numbered system will make it easier to troubleshoot engine conditions when examining the firing ends of the plugs. This system will also assist with plug rotation if reinstalling.

ISSUED			REVISED		
MO	DAY	YEAR	MO	DAY	YEAR
02	10	2010	08	29	2012









PAGE NO.	REVISION
4-1	-C-

4.2 TROUBLESHOOTING - ELECTRODE CONDITIONS

Poor engine performance may be due to worn rings or cylinders, improper fuel-air mixture, a worn ignition harness or a number of other conditions. The appearance of the firing end of a spark plug is a good indicator of conditions that may exist within the engine.

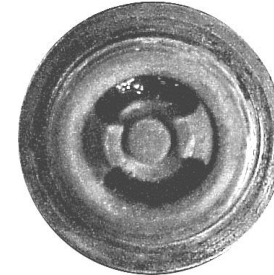
NOTE: The conditions shown below are representative of both massive electrode and fine wire plugs even though only the massive electrodes are shown.

			
New Condition	Normal Worn-Out Condition	Severe Worn-Out Condition	Carbon Fouled Condition
			
Oil Fouled Condition	Lead Fouled Condition	Bridged Electrode Gaps	Cracked Core Nose

4.2.1 WORN ELECTRODES

Normal

Indicated by a grey or brownish color on the firing end with few deposits. Electrodes are slightly worn, but not eroded or burned.

Clean, regap, test and reinstall plugs using a new copper mounting gasket (TEMPEST® part number UM-674).

Normally Worn-Out and Severe Indicated by excessively worn electrodes.

Discard plugs that are worn to beyond service limits per Gap Setting Procedure in paragraph 4.3.9. Replace with new TEMPEST® Aviation Spark Plugs or proper part number for the application.

ISSUED			REVISED		
MO	DAY	YEAR	MO	DAY	YEAR
02	10	2010	08	29	2012

Besides normal operation, other conditions that can cause electrode erosion are constant magneto polarity firing and capacitance after-firing. By properly rotating spark plugs, these effects can be reduced.

Constant polarity occurs with even-numbered cylinder magnetos. One plug fires with positive polarity causing excessive ground-electrode wear. Then the next plug fires with negative polarity causing excessive center-electrode wear.

Capacitance after-firing is caused by the stored energy in the ignition-shielded lead releasing after a normal-timed ignition.

To even out the wear, place spark plugs in the spark plug tray as in paragraph 4.3.10 (TEMPEST® part number AA-446™), identified by cylinder locations, then rotate according to Figure 4-15. Keep plugs in engine sets.

UREM37BY Electrode Wear

Due to their projected gap design, which helps prevent lead fouling, the TEMPEST® UREM37BY spark plugs do not wear like other TEMPEST® Aviation Spark Plugs with “massive” type ground electrodes. A severely worn UREM37BY spark plug displays bottle-necking of the center electrode and knife-edged type erosion of the ground electrodes.



New UREM37BY



Worn UREM37BY

Fine Wire Electrode Wear

The outstanding wear characteristics of the TEMPEST® fine wire plugs will allow continued use long after other types of plugs have worn out. The main limitation of these spark plugs are the internal resistor condition. As long as the resistance through the center electrode is below 5000 ohms, the resistor is good. However, the electrode erodes so slowly that as long as there is at least half of the width of the ground electrode remaining, the spark plug is serviceable.

ISSUED			REVISED		
MO	DAY	YEAR	MO	DAY	YEAR
02	10	2010	08	29	2012



PAGE NO.	REVISION
4-3	-C-

4.2.2 CARBON FOULING

Dry, fluffy, sooty deposits indicate the plug is operating too cold to burn off combustion deposits. Causes may be fuel related or ignition related.

Fuel related causes include rich fuel mixture, excessively lean mixture, faulty carburetor adjustment, excessive idling or improper idle mixture.

Ignition related causes include a failed plug, a failed lead, improper magneto timing or improper plug type (too cold).

Complete a magneto check by slowly increasing engine power to magneto, check level and then perform the magneto check. After a satisfactory check, idle the engine and check the idle mixture.

4.2.3 OIL FOULING

Indicated by oily, wet deposits and frequent misfires.

Causes include damaged pistons, worn or broken piston rings, worn valve guides, sticking valves, faulty ignition supply, or engine in break-in period.

Diagnose and repair engine problem. Clean, regap, test and reinstall plugs using a new copper mounting gasket (TEMPEST[®] part number UM-674).

4.2.4 LEAD FOULING

Indicated by hard ash-type deposits of lead.

Severely fouled plugs should be replaced with new TEMPEST[®] Aviation Spark Plugs. Lightly fouled plugs may be cleaned, regapped, tested and reinstalled using a new copper mounting gasket (TEMPEST[®] part number UM-674).

4.2.5 BRIDGED ELECTRODE GAPS

Various deposits may bridge the gap between the electrodes of a plug causing misfires. These deposits may include carbon, lead or metallic particles.

Sometimes carbon particles may be cleared by slowly increasing engine power until the misfiring stops. Plugs with lead deposits or metallic particles will need to be cleaned. Otherwise, replace with new TEMPEST[®] Aviation Spark Plugs.

ISSUED			REVISED		
MO	DAY	YEAR	MO	DAY	YEAR
02	10	2010	08	29	2012



PAGE NO.	REVISION
4-4	-C-

4.2.6 CRACKED CORE NOSE

A crack in the core nose may be caused by abnormal engine operation or improper cleaning or gapping procedures.

Replace with new TEMPEST® Aviation Spark Plugs.

4.3 RECONDITIONING SERVICE

To be properly reconditioned a plug must be mechanically and electrically sound, have clean firing and terminal barrel ends, have sufficient electrode material remaining with proper contours and be properly gapped, have proper resistance value, and tested.

4.3.1 PRELIMINARY VISUAL INSPECTION

Use a lighted magnifier (TEMPEST® part number T553™) to visually inspect plugs to be reconditioned. Dispose of plugs with worn, damaged, or cracked parts such as shell hex, firing ends, shielding barrel, connector seat, threads, electrodes, terminals, insulators or terminal sleeves.

4.3.2 DEGREASING

Degrease spark plugs by lightly wiping with solvents, such as Stoddard Solvent, Hoppe's No. 9 Solvent, Varsol or a similar solvent. **Do not soak plugs in solvent and keep solvent out of the shielding barrel.**

Remove solvent with an air blast.

4.3.3 RESISTANCE EVALUATION

Check the resistor value before cleaning.

Military Specification MIL-S-7886, establishes specifications for aircraft spark plugs and directs that spark plug resistance should be measured at less than 10 volts. Measure between the terminal inside the lead well and the spark plugs center firing tip. The TEMPEST® AT5K™ tester, see Figure 4-1, does the job quickly and efficiently. The green LED means the sparkplug's resistance is excellent. If both the green and red LED's light up, the resistance is serviceable. If only the red LED illuminates, replace the spark plug with a new TEMPEST® spark plug. "AT5K™" means: "AT 5k Ohms, replace the spark plug". TEMPEST® resistors are stable. TEMPEST® spark plugs help prevent misfiring, wasted fuel, pollution, and expensive spark plug replacement due to high resistance problems.



Figure 4-1

ISSUED			REVISED		
MO	DAY	YEAR	MO	DAY	YEAR
02	10	2010	08	29	2012

4.3.4 CLEANING THE FIRING AND BARREL ENDS

Clean the firing and barrel ends of plugs with standard abrasive blast cleaning (TEMPEST® part number T560™) or equivalent. 40PSI Maximum recommended setting for this operation or other detail.

Glass beads are not good when it comes to cleaning aircraft spark plugs. Cement fills the space between the center electrode and the ceramic insulator in massive electrode spark plugs. Figure 4-2 shows the gap between the insulator and electrode before cementing.

Figure 4-3 shows an insulator assembly after cementing. The cement transfers heat to the insulator, then the insulator transfers the heat to the cylinder head. Eroding the cement by improper cleaning techniques opens the gap and makes a place for glass beads to lodge.



Figure 4-2



Figure 4-3

Figure 4-4 shows a competitive spark plug with glass beads jammed in the gap.

Figure 4-5 shows a TEMPEST® spark plug with glass beads jammed in the gap. It doesn't matter who made the spark plug, using glass beads or improperly sized media will create the problem and ruin spark plugs.

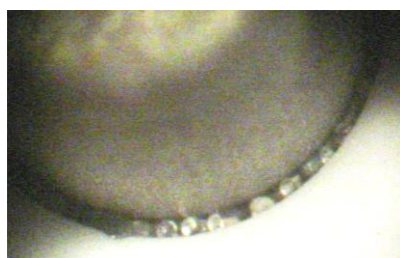

Figure 4-4

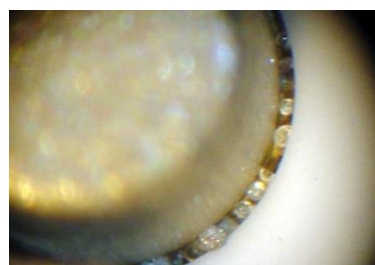

Figure 4-5

The glass beads will either melt, leaving a conductive lead film on the insulator that may lead to misfiring, or they'll fall out in the cylinder, doing damage there. You wouldn't put sand in your engine. You don't want glass beads in it either.

Glass beads break up into fine particles during use. Shop blast cabinets can propel the tiny particles at tremendous velocity.

ISSUED			REVISED		
MO	DAY	YEAR	MO	DAY	YEAR
02	10	2010	08	29	2012

Figure 4-6 shows microscopic bead particles stuck to a .011 inch diameter reference rod. Other beads and bead particles are in the background. Those tiny particles erode away the cement and create a gap in which beads will stick.

Figure 4-7 shows the same tiny particles on the reference rod. In the background is properly sized sparkplug abrasive.

Figure 4-8 shows appropriate spark plug cleaning abrasive. Properly sized grains cannot get into the narrow gap and erode the cement.



Figure 4-6

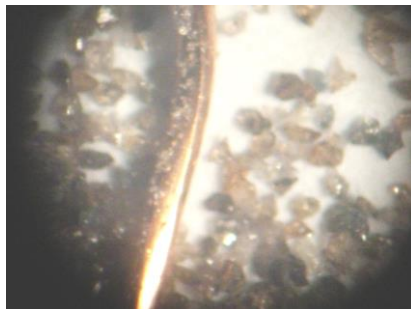

Figure 4-7

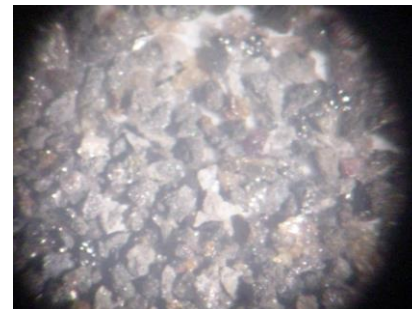

Figure 4-8

Spark plug abrasives also break and wear during use. When they get small enough, they will erode the cement just like glass beads do. That's why you should never add new spark plug abrasive to worn abrasive in your spark plug cleaner. Throw out the used abrasive and replace it with new. Check every few spark plugs with a 10X loupe. If the abrasive is attacking the cement the abrasive is worn out. Change it. It's cheap.

Expensive spark plug cleaners aren't necessary for small shops. Figure 4-9 shows an inexpensive cleaner available from aircraft parts distributors and tool suppliers. It works well. A small, dedicated blast cabinet will work too, see Figure 4-10, if its reserved for spark plugs and used only with spark plug abrasives.



Figure 4-9



Figure 4-10

ISSUED			REVISED		
MO	DAY	YEAR	MO	DAY	YEAR
02	10	2010	08	29	2012

The rule to remember is: Always use the lowest air pressure that will work. For small blast cabinets that's usually 15 to 30 psi. For cleaners designed for spark plugs use the manufacturers recommended pressure. The purpose designed nozzles do not create excessive velocity at the recommended pressure.

A few two-second blasts while rotating and wobbling the spark plug in the machine are usually sufficient. Get the heavy deposits off the electrodes and insulator tip, then stop. Don't focus on getting the insulator snowy white. You're just eating away the electrodes and insulator and wasting your time!

"Getting the lead out" isn't the spark plug cleaning machine's job, see Figure 4-11.

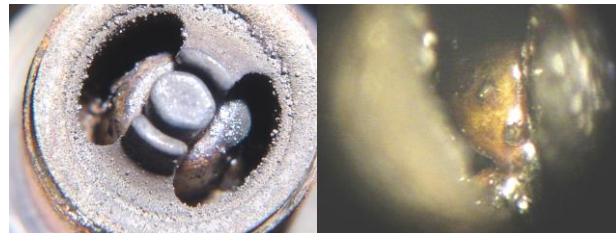

Figure 4-11

To remove heavy deposits, use a vibrator/cleaner like (TEMPEST® part number T551™, T552™, T559™ and T560™) or equivalent following the tool manufacturer recommended instructions. TEMPEST® spark plug cleaning tool (T550™) fits most commercial vibrator/cleaners and can be used on TEMPEST® Aviation Spark Plugs or competing brands. Remove heavy lead deposits in the insulator well with a pick or vibratory cleaner, see Figure 4-12.



Figure 4-12

Don't pry against the insulator or electrodes. If you have big lead balls, work them gently until you can free them. Then use the abrasive for a quick cleanup.

A few seconds of blasting in a glass bead box can ruin a spark plug. Three minutes spent doing it right can return the spark plug to service for another run. Figure 4-13 shows a properly cleaned spark plug. Notice that the cement is still in the gap.

NEVER use glass beads to clean a fine wire spark plug. There is no cement in fine wire spark plugs, see Fig. 4-14.

ISSUED			REVISED		
MO	DAY	YEAR	MO	DAY	YEAR
02	10	2010	08	29	2012



Figure 4-13

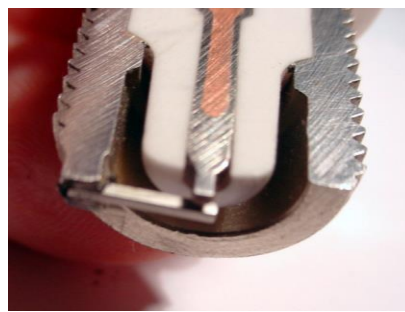

Figure 4-14

Glass particles will wedge between the electrode and the insulator and can crack the insulator.

Fine wire spark plugs normally don't need much cleaning. However, if you do need to get the lead out don't pry against the electrodes or insulators. If you blast the spark plug, use only high grade, new, spark plug abrasive. Use the lowest pressure possible and blast for only a second or two.

4.3.5 CLEANING THE TERMINAL WELL

Clean the shielding barrel insulators, using a cotton swab dipped in cleaning solvent, such as Stoddard Solvent, Hoppe's No. 9 Solvent, wood alcohol or a similar solvent. Using a rotating motion, run the swab up and down the inside of the well to remove the stains.

If this method doesn't complete the cleaning, dip a clean swab in the solvent and then dip in a mild abrasive such as Bon Ami™. Using a rotating motion, run the swab up and down the inside of the well to remove all stains.

Dip a second swab in solvent and completely clean out the abrasive residue.

4.3.6 CLEANING CONNECTOR SEATS

Use solvent to remove dirt and deposits from the connector seat. This ensures a tight seal and proper bond with the ignition lead.

If additional cleaning is needed, use fine grained sand paper to remove all remaining dirt and deposits.

Clean with the plug held in an inverted position to avoid particles falling deep into the shielding barrel.

Use an air blast to remove all traces of particles from the barrel. Carefully examine the barrel for cracks and dispose of any cracked insulator plugs and replace with new TEMPEST® Aviation Spark Plugs.

ISSUED			REVISED		
MO	DAY	YEAR	MO	DAY	YEAR
02	10	2010	08	29	2012

4.3.7 FIRING END INSPECTION

Use a lighted magnifier to thoroughly examine the firing end. Check for cleanliness, dryness and a clean terminal well.

4.3.8 CLEANING THE THREADS

Use a lighted magnifier to inspect the threads on the shell and the shielding barrel for condition and size. Dispose of plugs with heavily damaged threads.

CAUTION: Use care with a power driven brush. Do not use a wire exceeding 0.005" in diameter. Never brush the insulator or the electrodes.

Use a wire hand brush or power driven brush to thoroughly clean the threads.

Restore slightly damaged threads with a #2 three cornered file.

4.3.9 GAP SETTING PROCEDURES

CAUTION: Never bend the center electrode while setting the gap. Never apply pressure to the center electrode with the feeler wire gauge. This may fracture the ceramic insulator.

NOTE: Thoroughly clean plug before setting the gap.

Use a commercially available gap setting tool to set the gap following the tool manufacturer's instructions.

Use a GO and NO-GO round wire feeler gauge (TEMPEST® part number T554™) to measure gap width.

TEMPEST® recommends using the same gap setting as specified for new spark plugs.

Check for electrode erosion with the TEMPEST® T245™ erosion gage. Gap the plug to 0.016". A properly gapped, but fully worn plug will enter the hole in the erosion gage. If this happens, dispose of the plug and replace it with a new TEMPEST® Aviation Spark Plug.

UREM37BY can be gapped until the electrodes are worn to a point where it becomes difficult to properly adjust the gap.

ISSUED			REVISED		
MO	DAY	YEAR	MO	DAY	YEAR
02	10	2010	08	29	2012



PAGE NO.	REVISION
4-10	-C-

Fine wire spark plugs are gapped to 0.017” – 0.021” from the factory. The side wire itself should be flush with the top of the center electrode. If the gap exceeds this tolerance, the side wire can be gapped during regular maintenance. The Iridium material has outstanding resistance to electrical erosion, but is very brittle. Using small needle-nose pliers, grasp the side wire perpendicular to the face of the plug. Smoothly twist the pliers one time only to achieve the proper gap. There is very little spring back at the electrode when bending. Any additional adjustments are not recommended due to the brittle nature of the material. Broken side wires are not covered under warranty.

4.3.10 ROTATING SPARK PLUGS

After placing spark plugs in the spark plug tray (TEMPEST® part number AA-446™), exchange the long-lead plugs with the short-lead plugs as in Figure 4-15. This should be done at each inspection, cleaning, and gap setting interval to even out the wear caused by constant polarity and high lead capacitance.

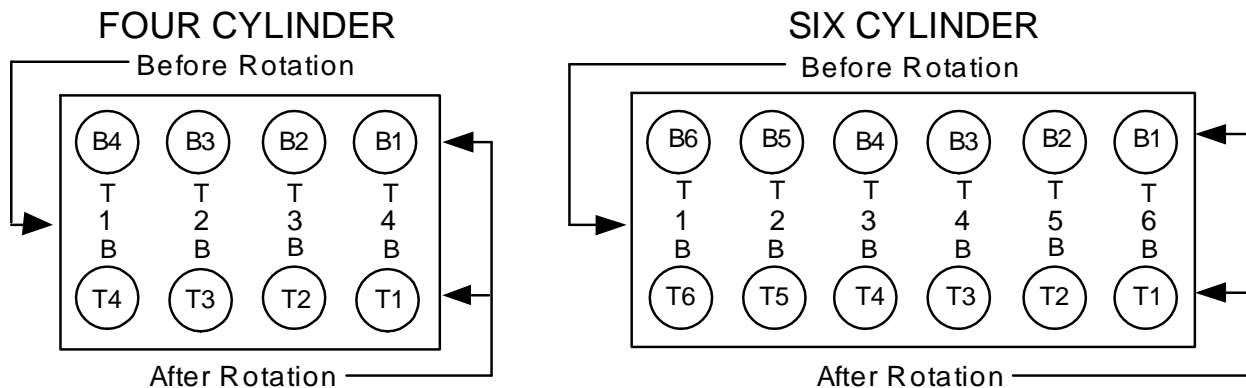

Figure 4-15

NOTE: It is not necessary to rotate plugs from cylinder to cylinder in a four cylinder engine equipped with single drive dual magneto or any engine equipped with the LASAR® system. However to minimize deposit buildup, rotate the plugs from top to bottom and from bottom to top.

ISSUED			REVISED		
MO	DAY	YEAR	MO	DAY	YEAR
02	10	2010	08	29	2012



PAGE NO.	REVISION
4-11	-C-

4.3.11 PAINTING SPARK PLUGS

Occasionally, plugs that have been in service for an extended period of time require cleaning and painting to preserve their cosmetic appearance.

1. Remove loose corrosion or loose plating using a hand-held stainless steel brush.
2. Degrease part as described in paragraph 4.3.2 "Degreasing".
3. Mask threads. Ensure that connector end and firing end are also masked.
4. Apply a light coat of paint.
5. Allow a 20-minute dry time for solvent flash off.
6. Apply a second coat of paint.
7. Dry according to paint manufacturer's instructions.

Recommended Paints:

- | | | |
|---------------------|-------------|----------------------------|
| • Plasti - Kote® | HOT PAINT | HP – 14 Aluminum |
| • RUST - OLEUM® | HIGH HEAT | 7778 Black |
| • RUST - OLEUM® | HARD HAT | V2185 Zinc - Rich |
| • Randolph Products | TT – P - 28 | Aluminum Aerosol High Heat |

ISSUED			REVISED		
MO	DAY	YEAR	MO	DAY	YEAR
02	10	2010	08	29	2012



PAGE NO.	REVISION
4-12	-C-

5.0 PRESERVING AND STORAGE

New TEMPEST® Aviation Spark Plugs come from the factory sealed in a plastic tube with one copper mounting gasket (UM-674).

To preserve reconditioned spark plugs when storing for future use, lightly brush a rust-proofing compound on the shielding barrel and shell threads.

CAUTION: Do not dip spark plugs in a corrosion preventive compound.

Carefully package the plugs using individual tubular cartons or individually wrap plugs in waxed paper and store in a suitable container.

For lengthy storage, use a ventilated storage cabinet heated with an ordinary light bulb. This is of particular importance in damp, humid climates or near coastal environments.

ISSUED			REVISED		
MO	DAY	YEAR	MO	DAY	YEAR
02	10	2010	08	29	2012



PAGE NO.	REVISION
5-1	-C-

6.0 WARRANTY

6.1 WARRANTY PERIOD

Refer to TEMPEST'S® Aviation Spark Plug Warranty Policy (Available at www.tempestplus.com)

6.2 WARRANTY PROCEDURES

Request for warranty consideration must be made to Aero Accessories, Inc. within 30 days of the date the spark plug(s) became inoperative. The spark plug(s) and the completed returned merchandise authorization (RMA) information form must be returned to Aero Accessories, Inc. through a TEMPEST'S® distributor with transportation charges prepaid.

ISSUED			REVISED		
MO	DAY	YEAR	MO	DAY	YEAR
02	10	2010	08	29	2012



PAGE NO.	REVISION
6-1	-C-