

GENERAL SPECIFICATIONS	
IGNITION TYPE	WASTED SPARK
MAX. INPUT RPM	3500 RPM
OPERATING TEMPERATURE RANGE	-38°C TO +107°C
VOLTAGE INPUT RANGE	8.5 - 30 V _{DC}
OPERATING POWER REQUIREMENTS @ 2700 RPM	1.00±0.2 A @ 14 V _{DC} 0.50±0.2 A @ 28 V _{DC}
MANIFOLD PRESSURE INPUT RANGE	5 - 45 inHg
TIMING ACCURACY	±2°
BUILD	surefly_6_18041701_con.zip
CHECKSUM	0057454B

REVISIONS				
ZONE	REV.	DESCRIPTION	DATE	APPROVED
ALL	PT-1	PROTOTYPE 1	04/14/2017	RVC
ALL	PT-2	PROTOTYPE 2	06/01/2017	RVC
ALL	IR	INITIAL RELEASE FOR PRODUCTION	05/21/2018	RVC
ALL	A	ECO 19-001	03/25/2019	RVC

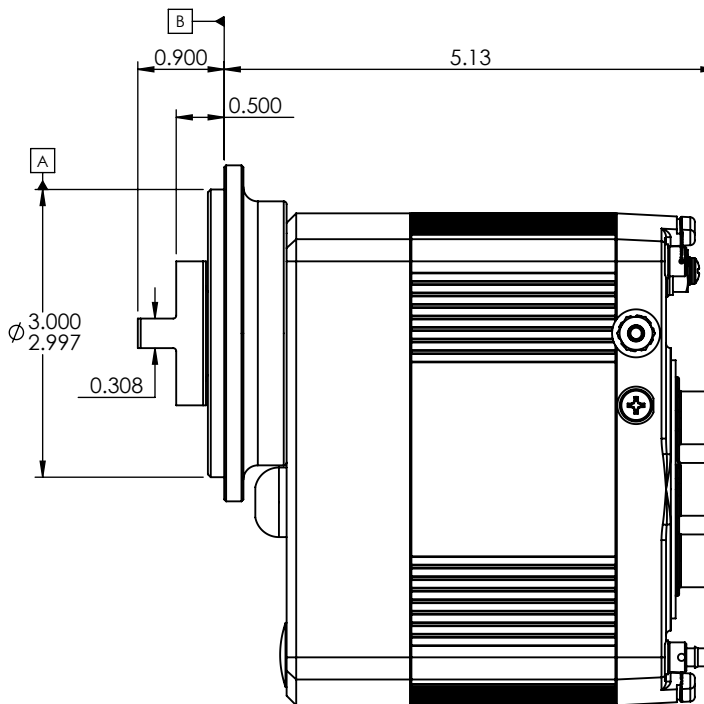

DIP SWITCH SETTINGS								
ENGINE TIMING	IGNITION ROTATION	TIMING OPTION	DIP SWITCH				LED CODE ON=SHORT OFF=LONG	TIMING SCHEDULE
			1	2	3	4		
20°	LEFT (L)(LN)	ADVANCED	OFF	OFF	OFF	OFF	----	A-20
	LEFT (L)(LN)	FIXED	OFF	ON	OFF	OFF	----	F-20
	RIGHT (R)(RN)	ADVANCED	ON	OFF	OFF	OFF	----	A-20
	RIGHT (R)(RN)	FIXED	ON	ON	OFF	OFF	----	F-20
22°	LEFT (L)(LN)	ADVANCED	OFF	OFF	OFF	ON	----	A-22
	LEFT (L)(LN)	FIXED	OFF	ON	OFF	ON	----	F-22
	RIGHT (R)(RN)	ADVANCED	ON	OFF	OFF	ON	----	A-22
	RIGHT (R)(RN)	FIXED	ON	ON	OFF	ON	----	F-22
24°	LEFT (L)(LN)	ADVANCED	OFF	OFF	ON	OFF	----	A-24
	LEFT (L)(LN)	FIXED	OFF	ON	ON	OFF	----	F-24
	RIGHT (R)(RN)	ADVANCED	ON	OFF	ON	OFF	----	A-24
	RIGHT (R)(RN)	FIXED	ON	ON	ON	OFF	----	F-24
26°	LEFT (L)(LN)	ADVANCED	OFF	OFF	ON	ON	----	A-26
	LEFT (L)(LN)	FIXED	OFF	ON	ON	ON	----	F-26
	RIGHT (R)(RN)	ADVANCED	ON	OFF	ON	ON	----	A-26
	RIGHT (R)(RN)	FIXED	ON	ON	ON	ON	----	F-26

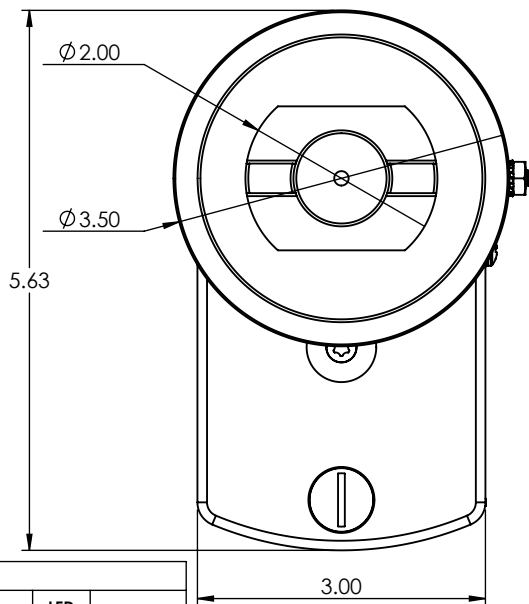
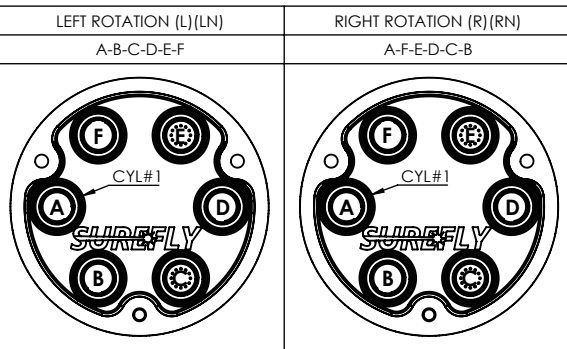

SureFly
Granbury, Texas

6 CYLINDER CONTINENTAL IGNITION

SCALE: 1:2	MATERIAL: N/A	FINISH: N/A
DIMENSIONS IN INCHES UNLESS OTHERWISE SPECIFIED		DRAWN BY: R. CONDY
TOLERANCES:		DATE: 05/21/2018
ANGLES ±1°	0.X ±0.050	0.XX ±0.030
	0.XXX ±0.010	
SHEET: 1/1		PART NO: SIM6C
		REV: A