

INNOVATION

7641-20

Sealed Aircraft Battery, VRLA, LT Technology, 24V, 20Ah



SPECIFICATIONS			
Model	7641-20		
Nominal Voltage, V	24		
One Hour Capacity, C1, Ah	20		
30 Minute Emergency Rate, C/2, A	35		
Weight, Lb. ±3%	45		
Power Performance	23°C (75°F)	-18°C (0°F)	-30°C (-22°F)
I _{pp} , A	1430	850	630
I _{pr} , A	920	560	410



7641-20
AVAILABLE NOW,
AT DISTRIBUTORS

Upgrade to the Next Generation of Lead-Acid Technology!

- ✓ TSO Authorized
- ✓ DO-160E Tested
- ✓ Sealed, VRLA, Non-Spillable
- ✓ 18 Month/1800 Hour Capacity Check Inspection
- ✓ 2 Year Warranty
- ✓ FAA-PMA
- ✓ EASA



TELEDYNE BATTERY PRODUCTS
Everywhere you look™

909.793.3131

GILLBATTERIES.COM

2018/3/29

INNOVATION



7641-20

AVAILABLE NOW AT DISTRIBUTORS

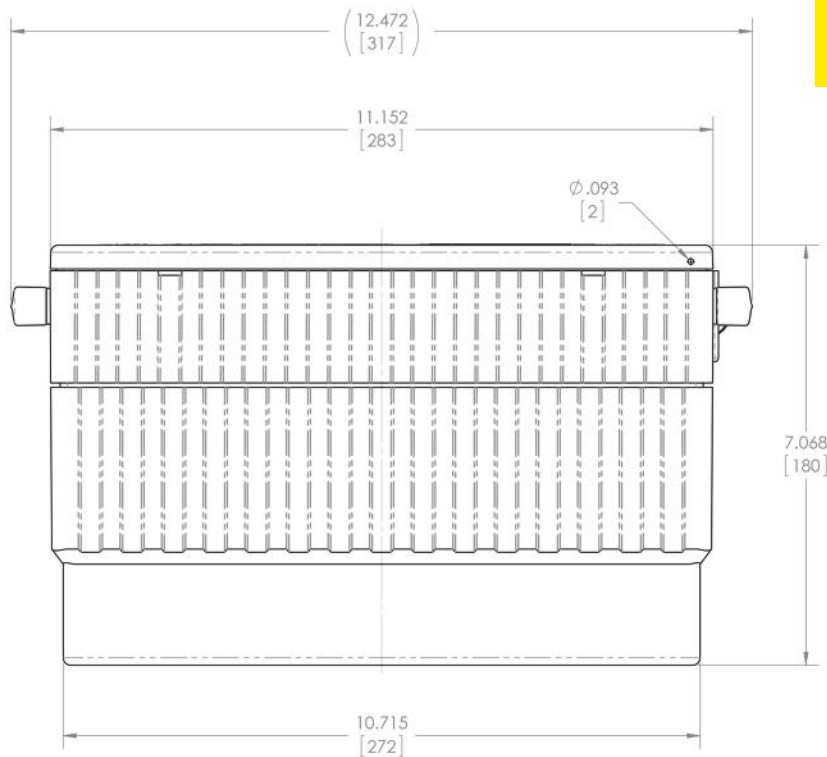
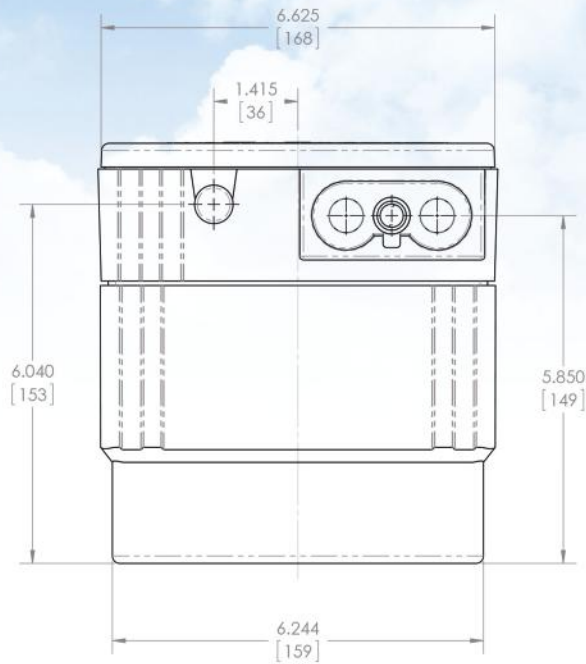

FAA-PMA APPROVED

MAKE	MODEL	STC KIT
Airbus	AS350B, AS350B1, AS350B2, AS350B3, AS350BA, AS350C, AS350D, AS350D1	SR02493LA
ATR-GIE	ATR42-200, ATR42-300, ATR42-320, ATR42-500, ATR72-101, ATR72-102, ATR72-201, ATR72-202, ATR72-211, ATR72-212, ATR72-212A	ST02886NY*
Bell	206A, 206B, 206L, 206L-1, 206L-3, 206L-4	SR01406LA*
Enstrom	TH-28, 480, 480B	NR
MD Helicopter Inc.	369, 369A, 369D, 369E, 369F, 369FF, 369H, 369HE, 369HM, 369HS, 500N, 600N	SR01427LA*
Schweizer	269D	NR

NR: Not Required *EASA Validated



TELEDYNE BATTERY PRODUCTS
Everywhere you look™

909.793.3131

GILLBATTERIES.COM

