



BRACKETT AERO FILTERS, INC.



INSTRUCTIONS

ASSEMBLY PART NO BA-111

APPROVED ON AIRCRAFT MODELS: SEE FAA APPROVED APPLICABILITY LIST

REPLACES: Cessna PN C294510-0401

FAA APPROVAL DATA: STC-SA71GL List No. 1
FAA-PMA Supplement No. 1

Your new polyurethane air filter element has been designed to provide maximum dust collecting efficiency, non-restrictive air flow, and economical element replacement, while maintaining a lightweight filter. The element has been treated with a distinctive treatment called a wetted agent and is approximately 98% efficient. The wetted agent is an accompaniment in the efficient capturing of dust. In addition, the element has received a fire retardant treatment. For the above reasons, replace the element each 200 hours of use/12 months or when 50% covered with foreign material. DO NOT WASH AND REUSE.

INSTALLATION INSTRUCTIONS

Install the Brackett Air Filter in the same manner as the original.

CAUTION: Make sure the flange end of the filter fits into the casting on the engine induction system. This is an alignment flange.

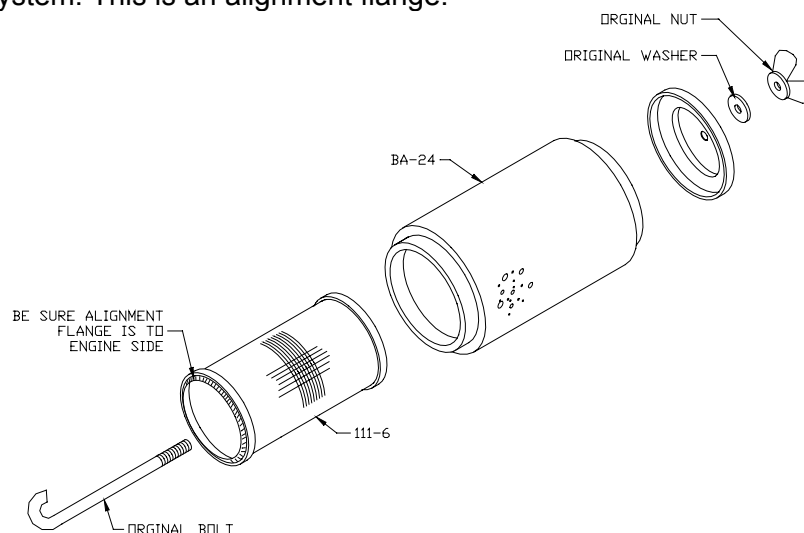

NOTE: After initial installation of filter assembly, fill out FAA Form 337 for return to service. On future replacement of parts this form will not be required.

SERVICING: Under normal conditions, replace filter element, PN BA-24, after 200 hours use or 1 year intervals. Under severely dusty conditions, check daily and replace when element is 50% covered with foreign material. For Continued Airworthiness Instructions, see Form I-194.

Instruction Sheet
Part No. 111-8
Date Rev: 08-19-04

Mfg. by:
BRACKETT AERO FILTERS, INC.
Kingman, AZ

**FAA APPROVED MODEL LIST (AML) NO. SA71GL
BRACKETT AERO FILTERS, INC.
FOR
INSTALLING AIR FILTERS**

Issue Date: April 17, 1995

ITEM	AIR FILTER MODEL NUMBER	TOP DRAWING		AIRCRAFT MAKE	AIRCRAFT MODEL	ORIGINAL TYPE CERTIFICATE NUMBER	CERT. BASIS	AML AMENDMENT DATE
		NUMBER	REVISION & DATE					
4	BA-111			Cessna	337/A/B/C/D/E/F/G/H	A6CE	CAR 3	-----
				Cessna	R172K	3A17	CAR 3	-----
				Maule	M-4-210, M-4-210C, M-4-210S, M-4-210T, M-5-210C	3A23	CAR 3	-----
				Reims Aviation	(Cessna) FR172K	A18EU	FAR 21.29	7/12/95
				Reims Aviation	(Cessna) F337E/F/G/H	A23EU	FAR 21.29	7/12/95
				Cessna	336	A2CE	CAR 3	2/5/96
5	BA-112			Cessna	R172E (USAF T-41B, -41C, -41D), R172F (USAF T-41D), R172G (USAF T-41C, -41D), R172H (USAF T-41D)	3A17	CAR 3	2/5/96
				Reims Aviation	(Cessna) FR172E/F/G/H/J	A18EU	CAR 3	2/5/96
				Piper	PA-18-150, PA-18A-150, PA-18S-150, PA-18AS-150 (SN 18-6964 and UP with item 110 of the TCDS installed)	1A2	CAR 3	-----
6	BA-113							
				Jimmie Thompson	Navion A	A-782	CAR 3	-----
*** END OF DATA ***								
*** END OF DATA ***								
*** END OF DATA ***								

BRACKETT AIR FILTER DOCUMENT I-194

PLACE IN AIRCRAFT RECORDS

CONTINUED AIRWORTHINESS INSPECTION
 REQUIREMENTS AS PER FAR 23.1529
 AND GENERAL PROCEDURES OF PART 43

INSPECTION INTERVALS: Pre-flight inspections, engine backfire inspection, 100 hour inspections, annual inspections, filter element replacements.

INSPECTION PROCEDURES

- A. Pre-flight inspection: Per Pilots Operating Handbook, check filter assembly for security, damage or 50% contamination of element face. If found report to maintenance personnel prior to flight.
- B. Engine start-up backfire inspection: Prior to flight, check the entire intake system for security or damage. If a fire was present, the downstream face of the foam element will show erosion. If any irregularities are found see Chart I and also refer to the Aircraft Maintenance Manual for the intake system.
- C. At element replacement intervals: With the element removed, inspect the filter grill, filter frame, filter mountings and entire intake system for security, wear and any deformation. Note: On filter assemblies with gaskets, visually inspect inside and outside of frame for any signs of gasket looseness, movement or deterioration. If found refer to Chart I or the proper maintenance manual for your aircraft or component.

PART			INSTRUCTIONS
	REPLACE	REWORK	
FRAME	X		COMPLETE NEW ASSEMBLY
GASKET	X		ON FILTER FRAME, REMOVE OLD NEOPRENE GASKET AND ALL TRACES OF ADHESIVE DOWN TO A CLEAN ANODIZED FRAME SURFACE. USE ADHESIVE 3M#847 OR DOW CORNING RTV-732. COAT ENTIRE MATING SURFACE (GASKET TO FRAME). APPLY ADHESIVE FOLLOWING MANUFACTURER'S LABEL DIRECTIONS. WHEN FRAME AND GASKET ARE PLACED TOGETHER, CLAMP OR WEIGHT DOWN AT .75 LB./SQ. IN. OF CONTACT AREA. ALLOW TO CURE 24 HOURS PRIOR TO INSTALLATION. PRIOR TO REINSTALLATION OF FILTER, CHECK AIRBOX MATING SURFACE FOR IRREGULARITIES. IF FOUND, CORRECT PER MANUFACTURER'S REQUIREMENTS. UPON REINSTALLATION CHECK THAT THE GASKET MAKES 100% CONTACT. THE GASKET SHOULD BE COMPRESSED 50% FOR OPTIMUM SEAL.
GRILL	X		REPLACE WITH NEW GRILL
HARDWARE	X		REPLACE UNSERVICEABLE WITH NEW
SCREEN	X		COMPLETE NEW ASSEMBLY
SCREEN/GASKET	X		COMPLETE NEW ASSEMBLY (ASSEMBLIES USING SCREEN GASKETS PRE 1981; BA-4106, BA-5110 AND BA-8110.)
ELEMENT	X		REPLACE ELEMENT