

USER IS RESPONSIBLE FOR VERIFICATION OF CURRENT REVISION BEFORE USING THIS DOCUMENT. DOCUMENT CONSIDERED "REFERENCE ONLY" IF NOT THE CURRENT REVISION.

REVISIONS				
ECO	REV.	DESCRIPTION	BY	DATE
123514	J	1) REDRAWN IN SOLIDWORKS; 2) FORMAT: HET WAS SKYTEC; 3) DESCRIPTION: CHANGED TO "ST2 INSTALLATION INSTRUCTIONS"; 4) REMOVED PMA DATA TABLE AND LABEL GRAPHIC	EAB	10/20/16
124308	K	1) UPDATED VIEWS WITH JUMPER FOR ALL MODELS	EAB	03/08/17

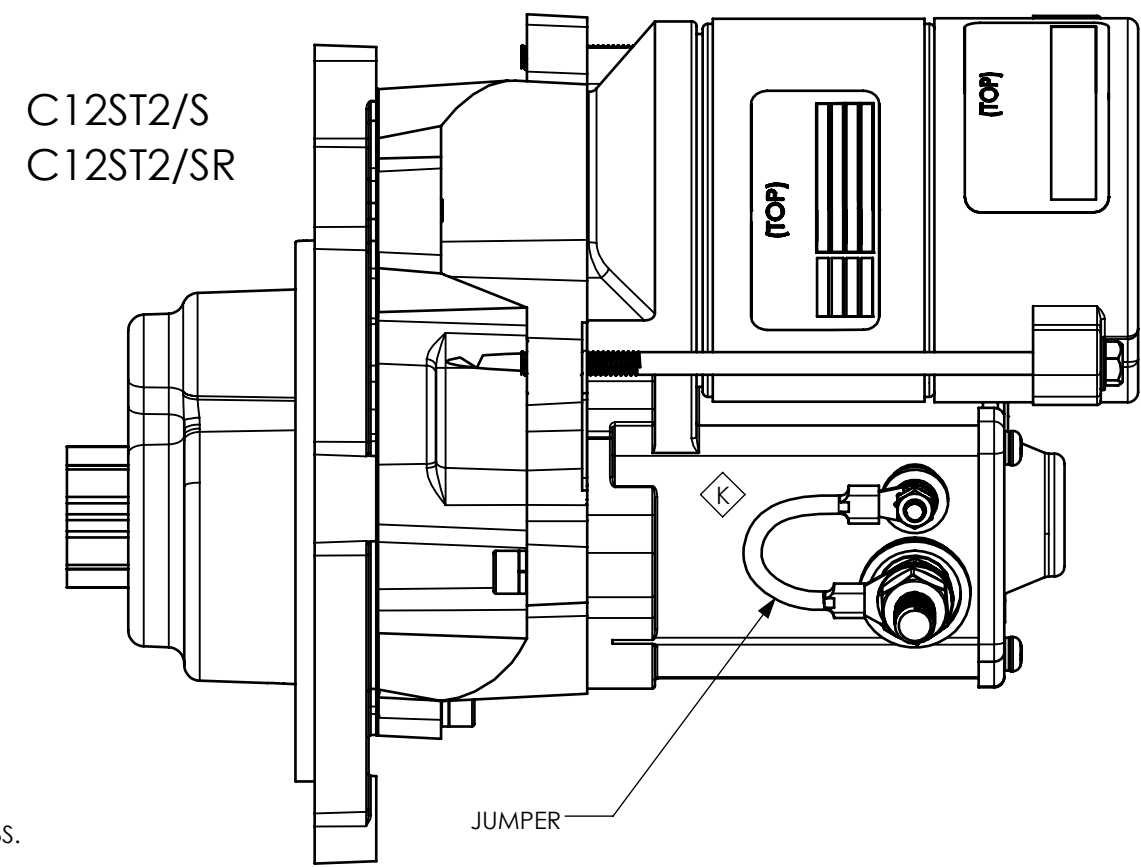
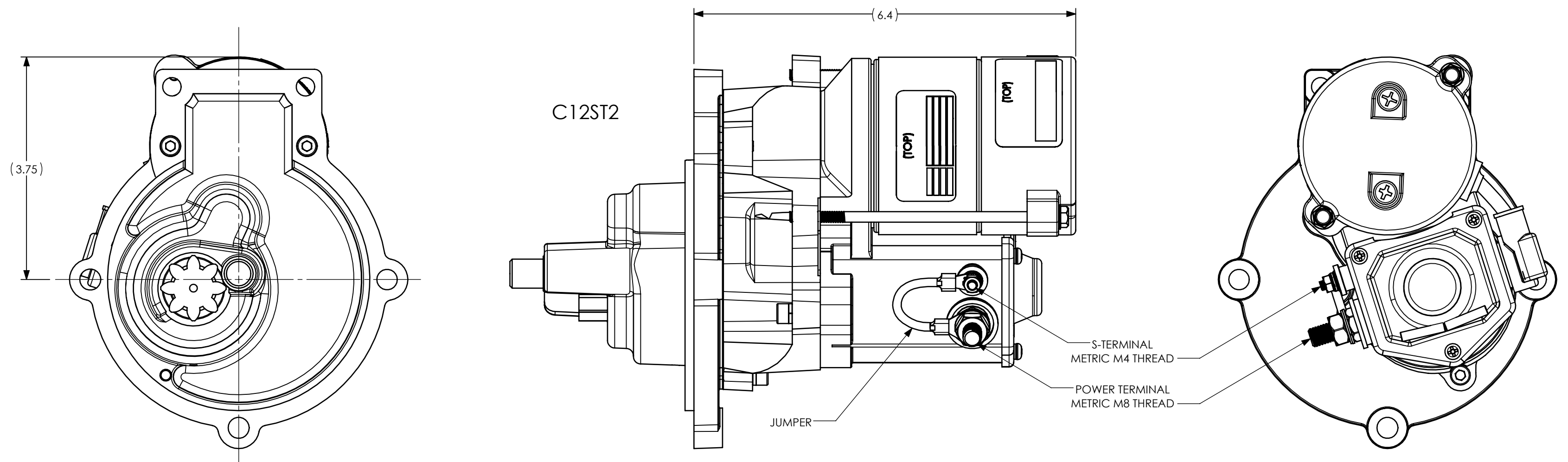

INSTALLATION INSTRUCTIONS:

1. DISCONNECT NEGATIVE (-) TERMINAL OF AIRCRAFT BATTERY.
2. DISCONNECT POWER CABLE FROM OLD STARTER AND REMOVE OLD STARTER FROM ENGINE.
3. INSTALL NEW STARTER WITH NEW GASKET USING EXISTING HARDWARE.
4. TIGHTEN HARDWARE TO TORQUES SHOWN IN TCM ENGINE OVERHAUL MANUAL (TYP. 275-325 IN-LBS.).
- 5A. FOR "KEY START" REPLACEMENT, ENSURE JUMPER WIRE IS INSTALLED BETWEEN STARTER POWER TERMINAL AND STARTER S-TERMINAL USING SUPPLIED HARDWARE. CHECK NUT TORQUE ON STARTER S-TERMINAL TO BE 25 IN-LBS.
-OR-
- 5B. FOR "PULL START" REPLACEMENT USING STC SE10076SC & SA 10077SC, ENSURE JUMPER WIRE BETWEEN STARTER POWER TERMINAL AND STARTER S-TERMINAL IS REMOVED AND WIRE HARNESS IS INSTALLED. TORQUE S-TERMINAL NUT TO 25 IN-LBS.
6. INSTALL THE POWER CABLE ON THE POWER TERMINAL OF THE STARTER WITH A MS25171-2S OR SIMILAR TERMINAL NIPPLE AND LOCK WASHER & NUT SUPPLIED. TIGHTEN SUPPLIED METRIC M8 NUT TO 50 IN-LBS.
7. CHOCK AIRCRAFT AND CLEAR PROP BEFORE RECONNECTING NEGATIVE (-) TERMINAL OF AIRCRAFT BATTERY.
8. CONTINUED AIRWORTHINESS: THE STARTER SHOULD BE OVERHAULED BY SKYTEC AT 2700 HOURS OR WHEN A MAJOR OVERHAUL IS PERFORMED ON THE ENGINE ON WHICH IT IS INSTALLED. IN CASE OF STARTER MALFUNCTION OR FOR OVERHAUL, SEE WWW.SKYTECAIR.COM TO OBTAIN INSTRUCTIONS FOR RETURNING THE STARTER TO SKYTEC. NO OTHER MAINTENANCE IS REQUIRED OR RECOMMENDED.

SPECIFICATION CLASSIFICATION		
CLASSIFICATION	DIMENSION CONVENTION	NOTE NO. CONVENTION
CRITICAL	<XX.XX>	<#>
MAJOR	[XX.XX]	[#]
MINOR	XX.XX	#
REFERENCE	{XX.XX}	{#}

UNLESS OTHERWISE SPECIFIED
 DIMENSIONS ARE IN INCHES AND APPLY AFTER HEAT TREAT AND PLATING
 .X = ±.015
 .XX = ±.010
 .XXX = ±.005
 ANGLES ±1°
 BREAK ALL EDGES AND MACHINE ALL INSIDE CORNER FILLETS .015 MAX.
 SURFACE FINISH $\sqrt{32}$
 THIS DRAWING CONTAINS INFORMATION THAT IS CONFIDENTIAL AND PROPRIETARY TO HARTZELL ENGINE TECHNOLOGIES. THIS DRAWING IS FURNISHED ON THE UNDERSTANDING THAT THE DRAWING AND THE INFORMATION IT CONTAINS WILL NOT BE COPIED OR DISCLOSED TO OTHERS EXCEPT WITH THE WRITTEN CONSENT OF HARTZELL ENGINE TECHNOLOGIES. WILL NOT BE USED TO THE DETRIMENT OF HARTZELL ENGINE TECHNOLOGIES, AND WILL BE RETURNED UPON REQUEST BY HARTZELL ENGINE TECHNOLOGIES.

GEOMETRIC SYMBOLS PER ANSI Y14.5
FLATNESS
STRAIGHTNESS
ROUNDNESS
CYLINDRICITY
PROFILE
PERPENDICULARITY
POSITION
CONCENTRICITY
SYMMETRY
ANGULARITY
PARALLELISM
CIRCULAR RUNOUT
TOTAL RUNOUT

DRAWN	EAB	10/20/16
ENGINEER	K. NORD	
APPRVD.	124308	
FINISH	N/A	
WEIGHT	N/A	
MATERIAL	N/A	
SIZE	SH 1	CODE ID
C	OF 1	65PY1

		2900 Selma Highway Montgomery, AL 36108	
		ST2 INSTALLATION INSTRUCTIONS	
DRAWING NO.		REV.	
70001		K	