

# TELEX

## *Airman 8 Headset*

*Maintenance & Overhaul Manual for Airman 8 Headset & Headphone*



## Record of Revisions

<b>Rev No.</b>	<b>Revision Date</b>	<b>Change Description</b>
01	08/2018	Created
02	01/2019	Add CTNs to Sec2.4 Parts List

## Purpose of Manual

This manual contains information for the overhaul and servicing of the Airman 8 headsets.

## Technical Support

A liaison between the customer and factory is provided by the Bosch Product Support Department. Consultation and assistance on technical problems, part information, and availability of local and factory repair facilities is available. When writing, include all information concerning problem and mail to:

**Bosch Communications, Inc.**

**8601 Cornhusker Hwy**

**Lincoln, NE 68507 U.S.A.**

**Attn: Aircraft Product Support Mgr.**

**Telephone: 877.863.4168**

## Parts Ordering

Replacement parts may be ordered from our parts department. When ordering, please include the following information:

- Model Number
- Part Description
- Part Number
- Quantity

Mail To:

**Bosch Communications, Inc.**

**8601 Cornhusker Hwy**

**Lincoln, NE 68507 U.S.A.**

**Attn: Parts Department**

**Telephone: 800.553.5992**

**Fax: 402.467.3279**

**E-mail: [repair.lincoln@us.bosch.com](mailto:repair.lincoln@us.bosch.com)**

## Repairs

In order to maintain the FAA certification, all repairs to the headset must be made only by persons authorized under Part 43 of the Federal Aviation Agency regulations. Bosch offers full support, repair, and recertification.

## Safety Precautions



---

**CAUTION:**

This information is for use by qualified personnel only. Have all service work and repairs performed by a trained technician.

---

- Unauthorized changes, modifications, or alterations to the product are prohibited.



---

**CAUTION:**

An ESD protection method should be applied before proceeding with any Mechanical/Electrical instructions

---



---

**CAUTION:**

Use of any replacement part, which does not have the same specifications, may cause malfunctioning of the device and could make the product not air worthy!

---

**NOTE:**

Any material to be disposed of should be done according to local environmental laws.

---

# Table of Contents

---

## **CHAPTER 1**

<b>Introduction &amp; Specifications.....</b>	<b>7</b>
1.1 Introduction .....	7
1.1.1 General Description .....	7
1.1.2 Models Covered .....	7
1.2 Specifications .....	7
1.2.1 For current specifications, see:.....	7
1.3 Reference View .....	8

## **CHAPTER 2**

<b>Parts List and Disassembly/Assembly.....</b>	<b>9</b>
2.1 Parts List.....	9
2.2 Reference Views .....	10
2.3 Disassembly/Assembly .....	11
2.3.1 Disassembly .....	11
2.3.1.1 Remove the headband cover clips (if present) .....	11
2.3.1.2 Replace Cushions and Windscreen .....	12
2.3.1.3 Remove the mic prefilter.....	14
2.3.1.4 Remove the Yoke Assembly from the Headband Assembly .....	14
2.3.1.5 Boom Side Disassembly .....	15
2.3.1.6 Non-Boom Side Disassembly .....	17
2.3.2 Assembly.....	20
2.3.2.1 Boom Side Assembly .....	20
2.3.2.2 Non-Boom Side Assembly.....	25
2.3.2.3 Attach the mic prefilter .....	29
2.3.2.4 Reinstall the headband cover .....	29
2.3.2.5 Replace the Yoke Assembly from the Headband Assembly .....	30
2.3.2.6 Replace the headband cover clips (if present).....	31
2.3.2.7 Replace Cushions and Windscreen .....	32

## **CHAPTER 3**

<b>Maintenance.....</b>	<b>35</b>
3.1 Troubleshoot and Maintenance .....	35
3.1.1 Recommended Maintenance Schedule .....	35
3.1.2 Physical Inspection.....	37
3.1.2.1 Review all plastic parts for cracks or breaks.....	37
3.1.2.2 Review all cables for obvious signs of damage to the insulating materials.....	37
3.1.2.3 Review user replaceable items .....	37
3.1.3 Talk Test.....	37
3.1.4 Microphone Troubleshooting and Workflow.....	39

3.1.4.1 Validate Continuity From Plug to PCBA .....	39
3.1.4.2 Validate Mic PCBA .....	39
3.1.4.3 Microphone/Amplifier Sensitivity Check.....	39
3.1.4.4 Microphone Sensitivity Adjustment .....	40
3.1.5 Speaker Troubleshooting and Workflow .....	41
3.1.5.1 Speaker Sensitivity and Frequency Response Verification .....	42
3.1.5.2 Measure the Resistance (Plug to PCBA) .....	42
3.1.5.3 Validate the Boom Side PCBA.....	42
3.1.5.4 Validate the Non-boom Side PCBA .....	42
3.1.6 ANR Troubleshooting and Workflow .....	43
3.1.6.1 Cleaning the Headset and Connectors .....	45
3.1.6.2 Cleaning the Ear Cushions and Headband Pads .....	45
3.1.6.3 Replacing Ear Cushions and Headband Pads .....	45
3.1.6.4 Installing and Replacing the Hygienic Covers .....	45
3.1.6.5 Replacing the Windscreen .....	46
3.1.6.6 Headset Storage .....	46

## **CHAPTER 4**

<b>Wiring / Connectors</b> .....	<b>49</b>
4.1 Wiring Diagrams.....	49
4.1.1 Wiring Diagram Airman8- 2010 and Airman8-0211 .....	49
4.2 Connectors .....	50
4.2.1 PJ-068/PJ055 Connector Diagram for Airman8-0210.....	50
4.2.2 XLR Connector Diagram for Airman8-0211.....	51

# *Introduction & Specifications*

## 1.1 Introduction

### 1.1.1 General Description

The Telex Airman 8 is a lightweight noise-reducing headset designed specifically for optimizing pilot communications in commercial and business turbine aircraft. Building on the tradition of the Airman 850, the Airman 8 has improved durability, intelligibility, and comfort. The Airman 8 is among the lightest **ANR** (Active Noise Reduction) headset on the market and the only FAA approved ANR headset to utilize Telex's proprietary battery-free, noise-reduction system.

### 1.1.2 Models Covered

TABLE 1. AIRMAN 8 Models and Connector/Wiring

MODEL NUMBER	DESCRIPTION
AIRMAN8-0210	DOUBLE SIDE ANR HEADSET 2PJ 600 OHM
AIRMAN8-0211	DOUBLE SIDE ANR HEADSET XLR5 600 OHM

## 1.2 Specifications

**IMPORTANT:** This document uses FAA standard HATS (Head and Torso Setup) for specification measurement testing.

### 1.2.1 For current specifications, see:

- Airman 8 Technical Manual (F01U307704) located on the website.
- Airman 8 Technical Data Sheet (F01U307701) located on the website.

## 1.3 Reference View

1. Headband Holder and Pad
2. Headset Slider
3. Ear Cushion
4. Ear Cup Rotator
5. Boom Rotator
6. Cord with Strain Relief
7. Boom
8. Microphone/Windscreen





## *Parts List and Disassembly/Assembly*

### 2.1 Parts List

Item	CTN	PART NO.	DESCRIPTION	MODEL	
				-0210	-0211
1 <sup>a,b</sup>	AIRMAN7-0905	F.01U.313.420	CARRYING CASE	1	1
	S-F01U342107	F.01U.342.107			
2 <sup>b</sup>	AIRMAN7-0900	F.01U.313.415	WINDSCREEN (2PCS)	1	1
	S-F01U327249	F.01U.327.249	WINDSCREEN (SINGLE)		
3 <sup>b</sup>	AIRMAN7-0906	F.01U.313.421	HEAD PAD	1	1
	S-F01U342089	F.01U.342.089			
4 <sup>a, b</sup>	AIRMAN8-0901	F.01U.313.996	SANITARY COVER, AIRMAN 8 (10PCS)		
	S-F01U342106	F.01U.342.106	SANITARY COVER, AIRMAN 8 (2PCS)		
5 <sup>b</sup>	AIRMAN8-0900	F.01U.313.418	EAR CUSHION, AIRMAN 8 (2pcs)	1	1
	S-F01U342110	F.01U.342.110			
6 <sup>a, b</sup>	AIRMAN7-0904	F.01U.313.419	CLOTHING CLIP	1	1
	S-F01U342113	F.01U.342.113			
7 <sup>b, c</sup>	AIRMAN7.0908	F.01U.344.857	MIC PREFILTER	1	1
	S-F01U346184	F.01U.346.184			
8 <sup>a</sup>	590404360	F.01U.109.816	SCREW, PT, PAN HEAD, K15 X 6MM, BLK ZINC	6	6
9 <sup>a</sup>	54857101	F.01U.150.106	WIRE 28 AWG 212 WHITE	2	2
10 <sup>a</sup>	54857103	F.01U.150.110	WIRE 28 AWG RED	2	2
11	S-F01U342083	F.01U.342.083	CORD UNIT, PJ Y-BLOCK	1	1
12	S-F01U342084	F.01U.342.084	EAR SHELL, BOOM SIDE, AIRMAN 8	1	1
13	S-F01U342085	F.01U.342.085	EAR SHELL, NON BOOM SIDE, AIRMAN 8	1	1
14	S-F01U342086	F.01U.342.086	COVER, NON BOOM SIDE, AIRMAN 8	1	1
15	S-F01U342087	F.01U.342.087	SWITCH ACTUATOR, AIRMAN 8	1	1
16	S-F01U342088	F.01U.342.088	GLIDER STOP (2PCS)	1	1
17	S-F01U342090	F.01U.342.090	HEADBAND COVER	1	1
18	S-F01U342094	F.01U.342.094	PCBA, NON BOOM SIDE, AIRMAN 8	1	1
19	S-F01U342096	F.01U.342.096	PCBA, BOOM SIDE, AIRMAN 8	1	1
20	S-F01U342097	F.01U.342.097	LABEL, TELEX	1	1
21	S-F01U344915	F.01U.344.915	CORD UNIT, XLR, 5M	1	1
22 <sup>d</sup>	S-F01U344917	F.01U.344.917	SPEAKER ASSY, AIRMAN 8 (including faceplate)	1	1
23	S-F01U344918	F.01U.344.918	OVER HEAD CABLE	1	1
24	S-F01U344922	F.01U.344.922	BOOM MIC ASSY, AIRMAN 8	1	1

25	S-F01U344923	F.01U.344.923	GLIDER YOKE ASSY, AIRMAN 8	1	1
26 <sup>a</sup>	S-F01U344924	F.01U.344.924	SCREW, PT PAN HEAD K15 X 3.5MM (25PCS)	4	4
27	ESP-F01U351884	F.01U.359.827	HEADBAND PAD HOLDER	1	1
28 <sup>a,e</sup>	S-F01U347879	F.01U.347.879	HEADBAND CLIP (2 PCS)		
29 <sup>a</sup>	S-F01U348100	F.01U.348.100	HEADBAND COVER AND HEADBAND PAD		

- a. Not shown.
- b. Either part number is acceptable.
- c. Acoustic cloth is included as part of this item.
- d. The speaker assembly includes the speaker and the faceplate.
- e. Only applies to earlier versions of the headset.

## 2.2 Reference Views

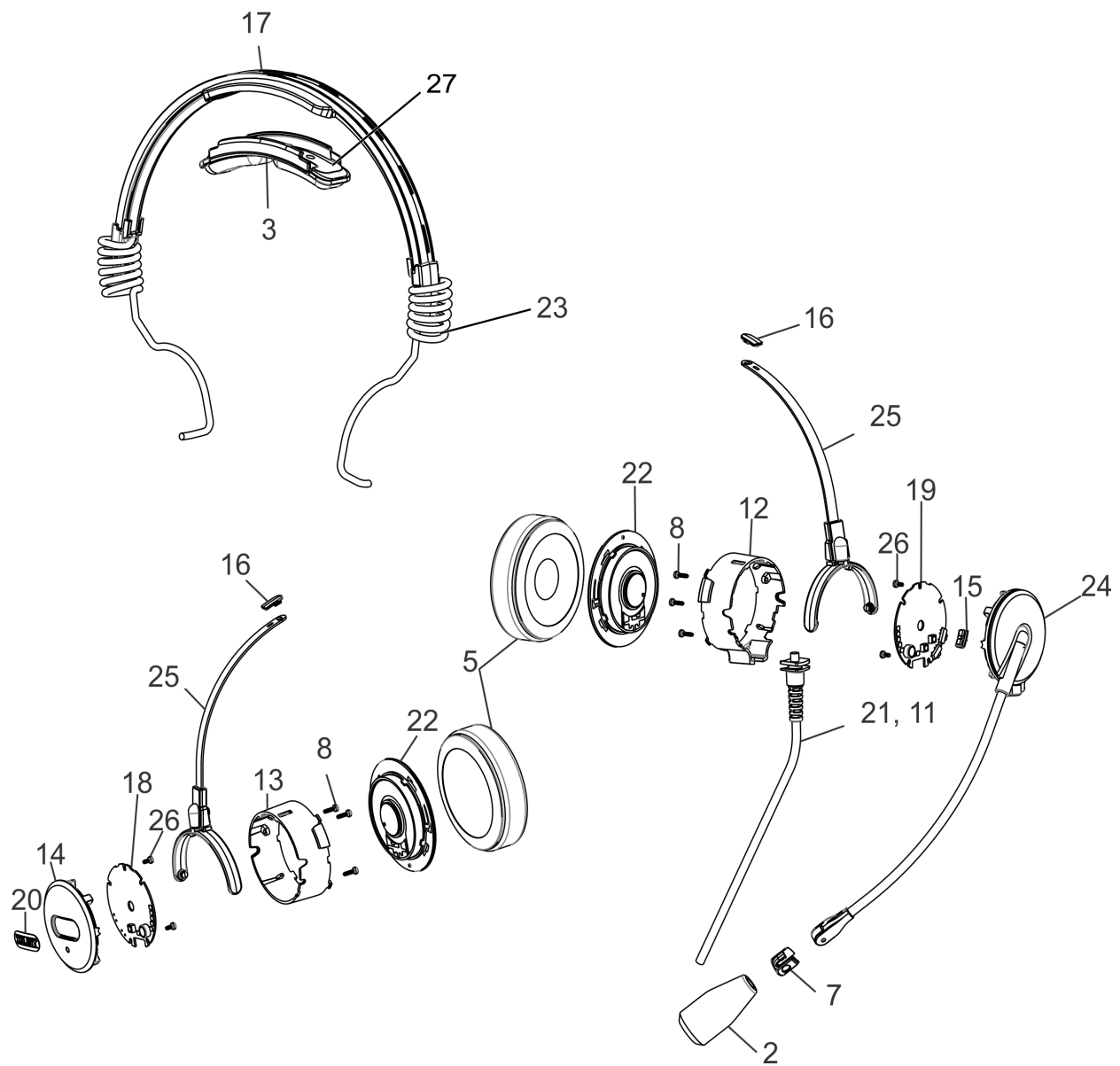

FIGURE 1. Airman 8 Basic Assembly

## 2.3 Disassembly/Assembly

The following procedure describes the complete disassembly of the Airman 8.

---

**IMPORTANT:** The removal process requires the following steps be followed in the order described.

---

- Assembly is the reversal of the disassembly procedure. Please take care when disassembling to note details that may be required in the re-assembly process, such as the locations of disconnected wires.
- When soldering, be careful not to touch the plastic housing of the headset/headphone with the soldering iron.

### 2.3.1 Disassembly

---

**IMPORTANT:** Only disassemble parts that are necessary for the repair.

---

#### 2.3.1.1 Remove the headband cover clips (if present)

To **remove the headband cover clips**, do the following:

1. Using a flat-head screwdriver, carefully **pry the clip** from the headband.

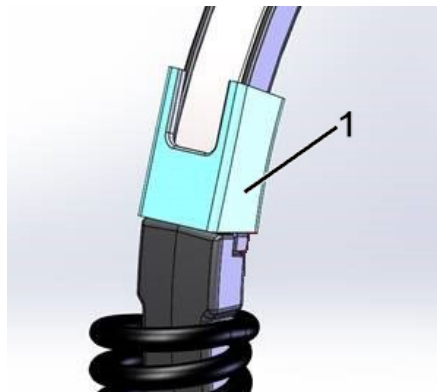

---

**IMPORTANT:** Some headsets have a snap feature (2) at each end of the headband cover. If this feature (highlighted in white) is present, the external clips (1) are not used.

---

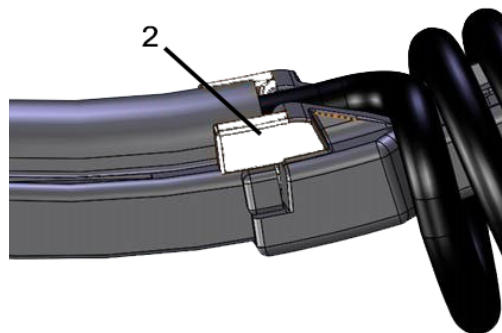

### 2.3.1.2 Replace Cushions and Windscreen

To ensure optimal product performance, it is recommended you replace ear cushions and headband pads periodically (every six months or sooner, if needed).

#### 2.3.1.2.1 Ear Cushion Replacement

To **replace the ear cushions**, do the following:

1. Grasp the **edge of the ear cushion** where it folds into the slot on the ear cup.
2. Gently pull the **ear cushion up and away from the ear cup**.
3. Starting at the top of the ear cup (1), carefully work **the cushion** around the cup (2) until it is in place (3).
4. Verify the **cushion** is seated properly by visually inspecting around the cushion before use.

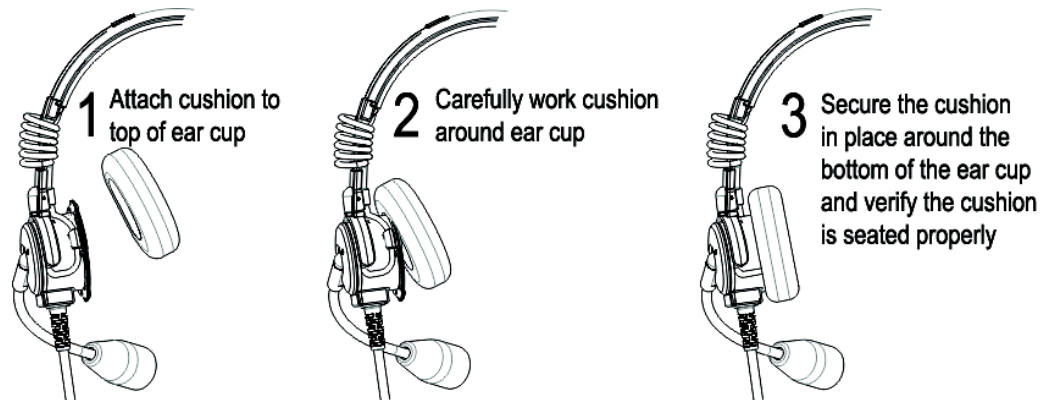

#### 2.3.1.2.2 Headband Pad Replacement

To **replace the headband pads**, do the following:

##### Early Version Headband

1. Carefully remove the **headband clips** (see "Remove the headband cover clips (if present)" on page 11).
2. Gently pull the **headband cover away from the headband**.
3. Starting at the either side of the headband carefully work **the replacement cover** around the metal headband until it is in place.

### Current Version Headpad Holder and Headpad

To **replace the headpad holder**, do the following:

1. At one end of the headpad holder, carefully **pry the holder** from the headband cover.

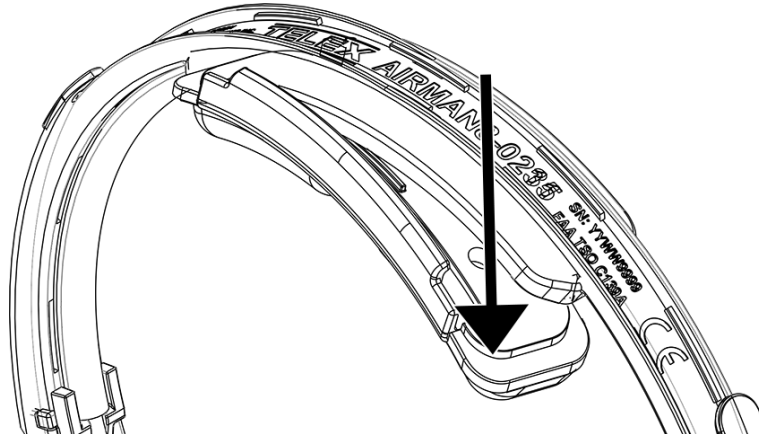

**NOTE:** Carefully twisting slightly on the headpad holder can help remove the piece easier

2. With the new headpad holder, hook **one side of the headpad holder over the headband cover**.
3. Snap the **other side of headpad holder in place**. Be sure the headpad holder edge is over the headband cover.

**NOTE:** The headpad holder should be centered on the headband cover.

To **replace the headpad**, do the following:

1. Grasp the **edge of the headband pad**.
2. Gently pull the **headband pad away** from the headpad holder.
3. Remove the **paper** from the sticky side of the new headband pad.
4. Align the **headband pad** with the recessed area on the headpad holder.
5. Firmly press the **headband pad into place**.

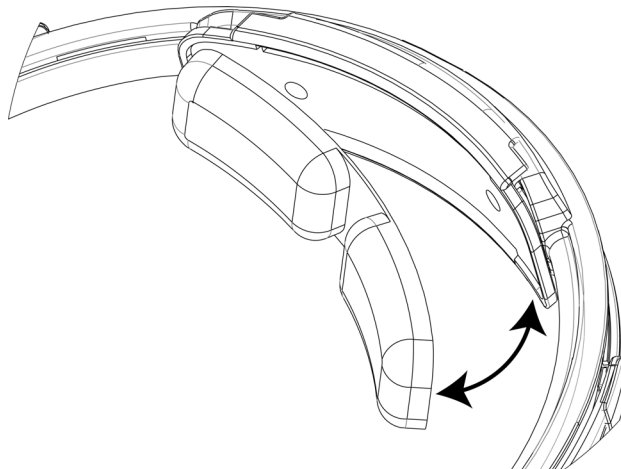

### 2.3.1.3 Remove the mic prefilter

To remove the prefilter, do the following:

1. Using your nail, carefully pry the **prefilter** from the mic.

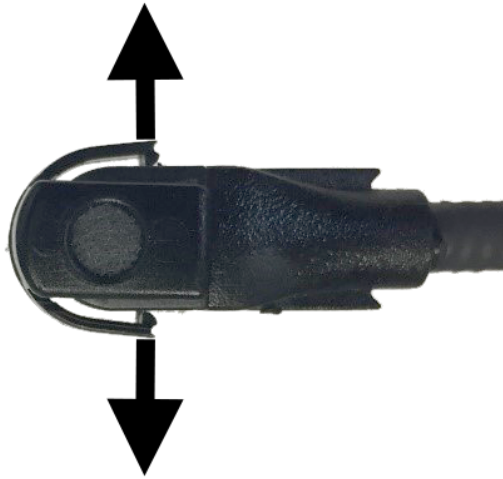

### 2.3.1.4 Remove the Yoke Assembly from the Headband Assembly

To remove the yoke assembly from the headband assembly, do the following:

1. On the yoke assembly, use a fingernail to lift the bottom edge of the **black plastic spacer**.
2. Swivel the **black plastic spacer** to the side and remove it from the assembly.

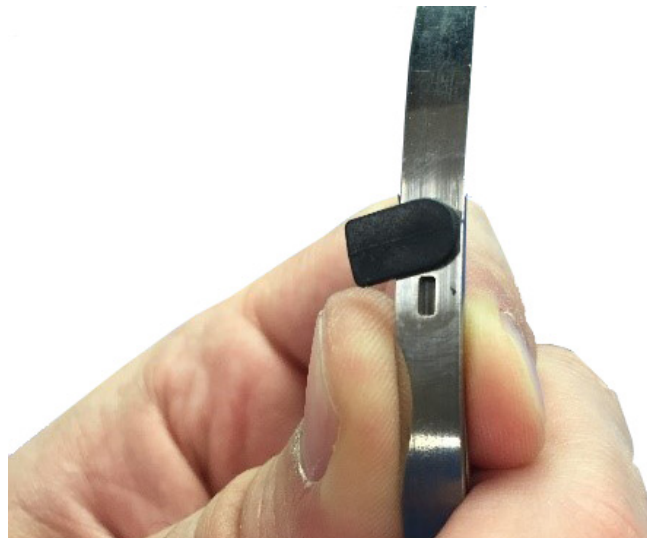

3. Slide the **yoke assembly** off of the headband.

### 2.3.1.5 Boom Side Disassembly

To remove the speaker assembly and sleeve, do the following:

1. At the same time, push the **two retaining cams** located in the speaker assembly out of the way.

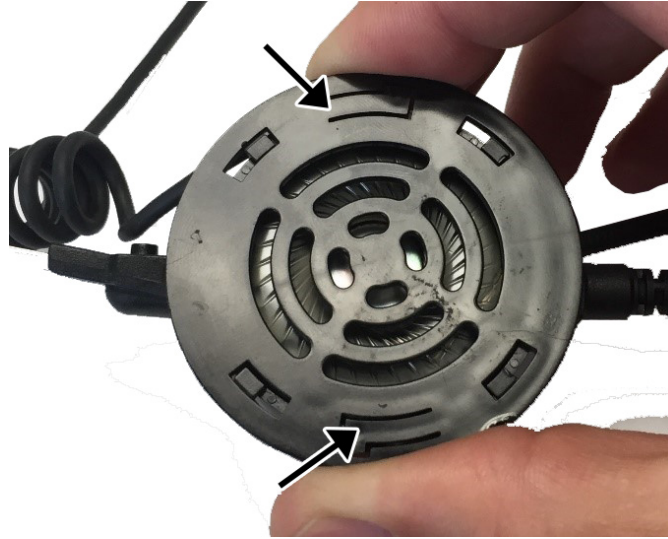

2. Rotate the **speaker faceplate** approximately 15° clockwise.

---

**IMPORTANT:** Do not pull more than 12mm away from the ear shell at this time.

---

3. Using a T-5 screwdriver, remove **three screws** (as shown).

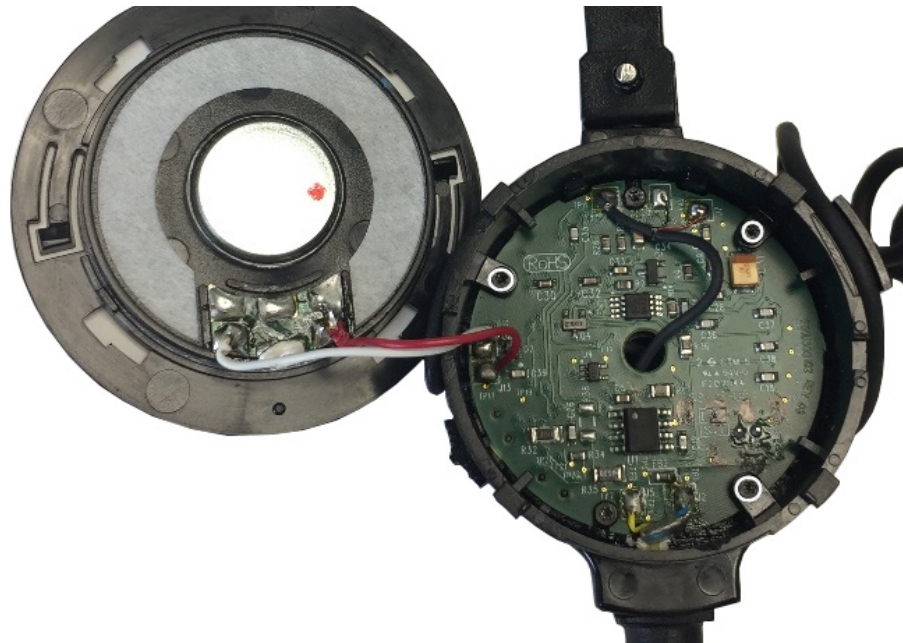

4. Remove the **housing and the yoke/glider assembly**.



5. Using a T-5 screwdriver, remove **two screws** (as shown).



6. Remove the **PCBA**.



- Using a soldering iron, carefully disconnect **the wires** from the speaker, overhead cord, boom mic assembly, and ANR mic solder terminals, as needed.

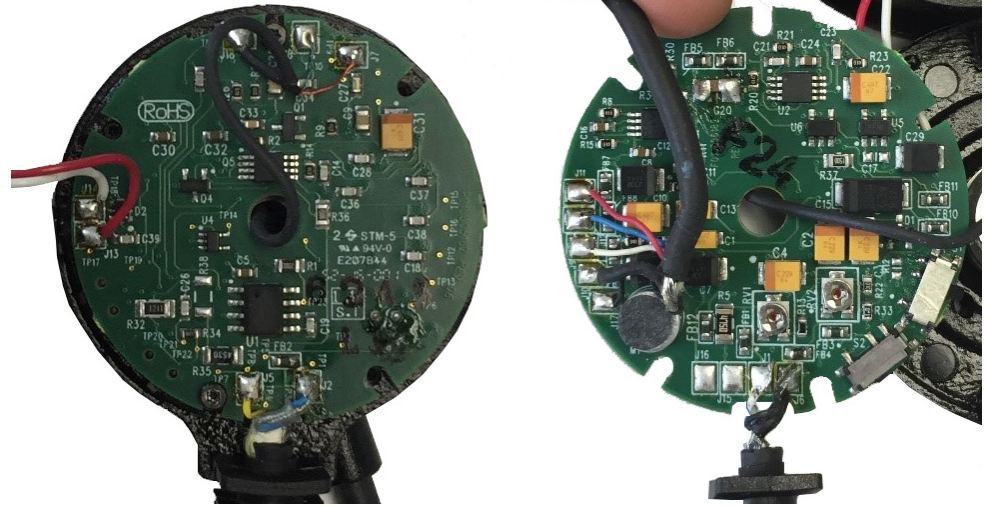

**IMPORTANT:** Take care to avoid touching the plastic housing with soldering iron.

### 2.3.1.6 Non-Boom Side Disassembly

**NOTE:** The following steps need to be done before going forward:

- “Remove the headband cover clips (if present)” on page 11
- “Replace Cushions and Windscreen” on page 12
- “Remove the mic prefilter” on page 14
- “Remove the Yoke Assembly from the Headband Assembly” on page 14

To remove the speaker assembly and sleeve, do the following:

- Pushing the two retaining cams simultaneously on the speaker assembly, rotate the **speaker faceplate approximately 15° clockwise**.

**NOTE:** To avoid pulling the wires from the board, do not pulling the speaker assembly more than 12mm from the ear shell.

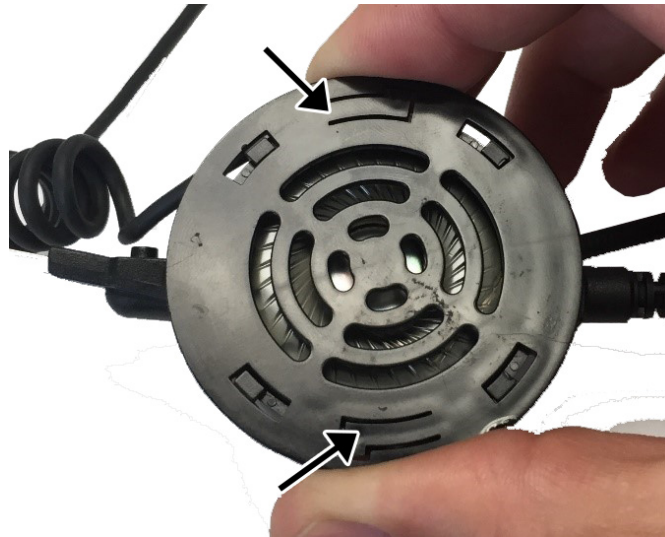

- Using a T-5 screwdriver, remove **three screws** (as shown).

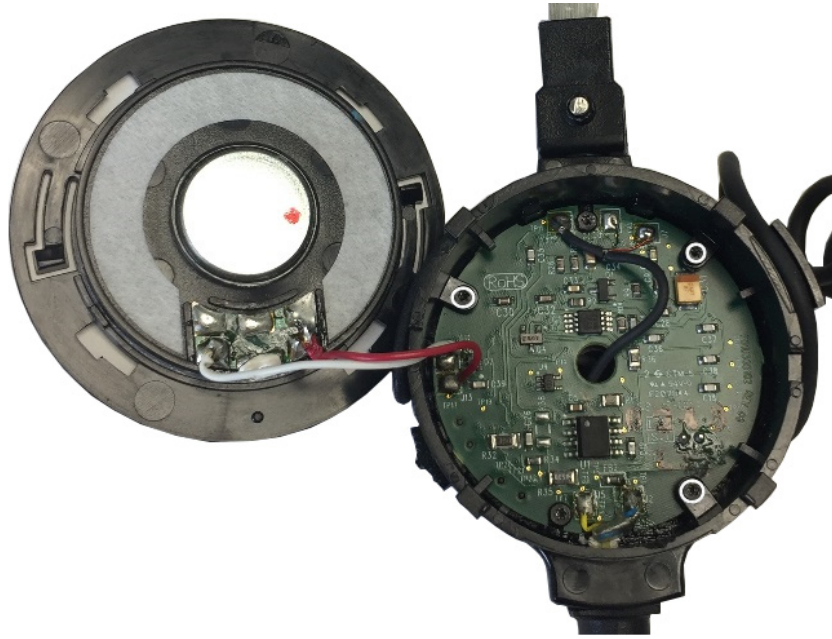

- Remove the **housing and the yoke/glider assembly**.



- Using a T-5 screwdriver, remove **two screws** (as shown).



- Remove the **PCBA**.
- Using a soldering iron, carefully disconnect **the wires** from the speaker and overhead cord, and ANR mic solder terminals, as needed.

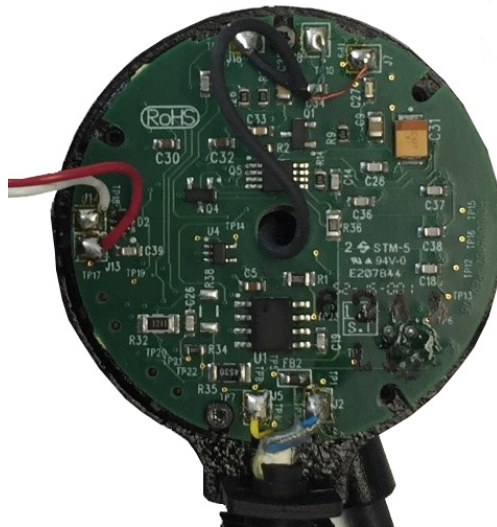

---

**IMPORTANT:** Take care to avoid touching the plastic housing with soldering iron.

---

## 2.3.2 Assembly

### 2.3.2.1 Boom Side Assembly

To assemble the boom-side assembly, do the following

1. Solder the overhead cord to PCBA.

J11	red
J12	blue
J9	white
J10	shield
J17	black

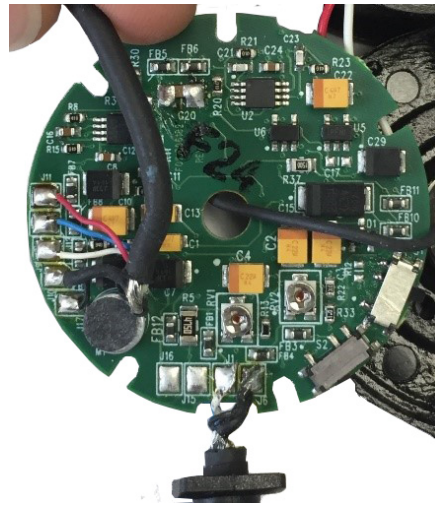

2. Solder the cable assembly to PCBA. (See “Wiring Diagram Airman8- 2010 and Airman8-0211” on page 49.)
3. Thread the boom mic wires through the center hole.
4. Solder the boom mic wires to the PCBA.

J7	red
J8	green
J18	shield

**NOTE:** Use shield as an anchor point so there is slack on smaller wires.

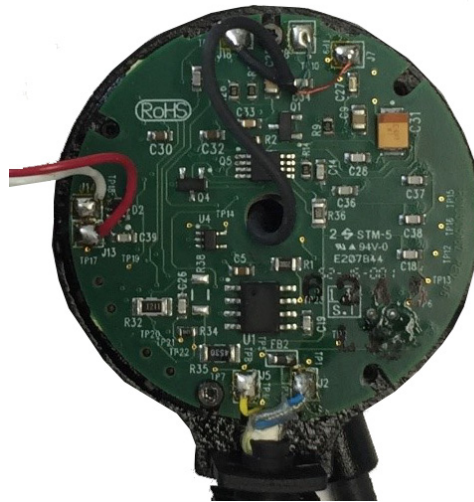

- Using the two shorter screws, attach the **PCBA to the boom mic assembly(1)**.

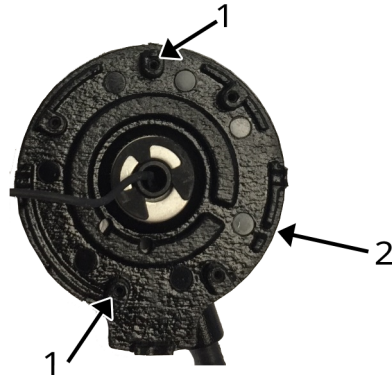

**NOTE:** Take care to route the overhead cord and headset cord through the corresponding grooves provided on the boom (2).

- Verify the **overhead cord is not caught between the ANR mic (3) and the boom mic housing**.  
*Position 1 is correct, position 2 is incorrect.*

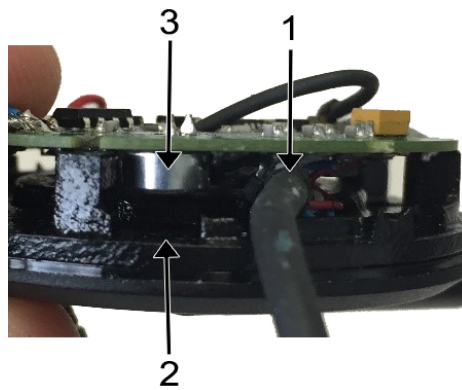

- Solder the **wires to the speaker**.

**NOTE:** Align the red wire with the polarity dot on the speaker.

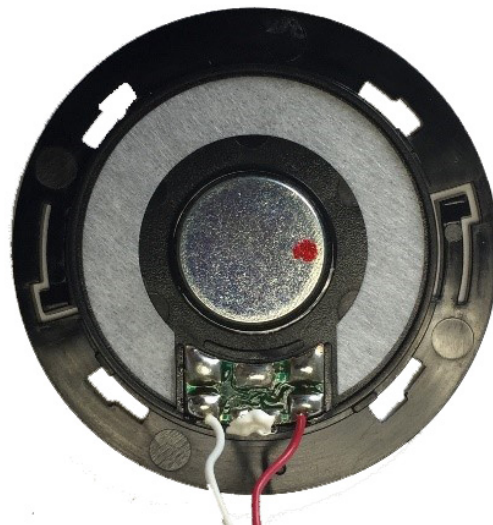

8. Route the **speaker wires through the housing and solder to the PCBA.**

J13	red
J14	white

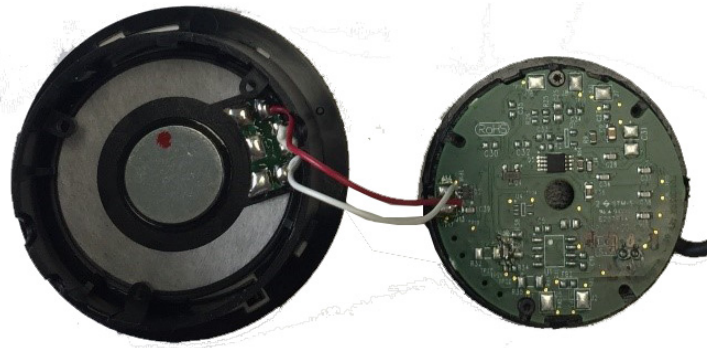

9. Place **yoke** on the housing.

**NOTE:** Take care to verify the orientation of the yoke, because it does not rotate 360°.

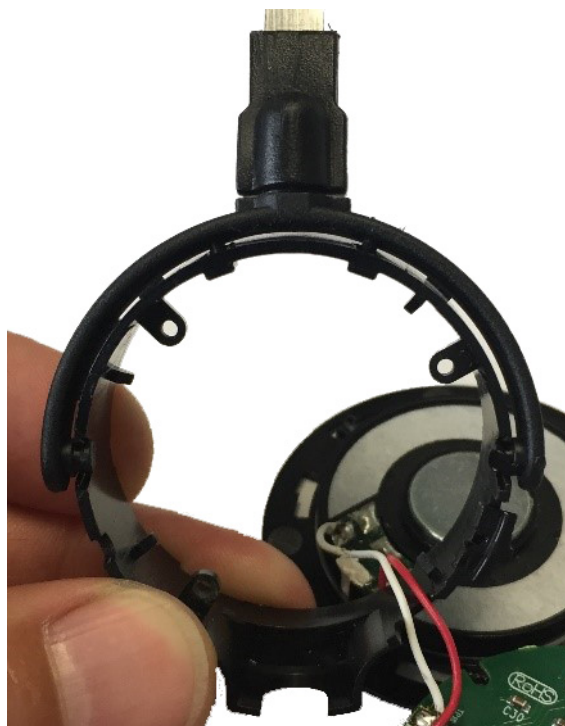

10. Place the **switch cover** on the ANR switch.

**NOTE:** The side with the deeper grooves goes toward the speaker.

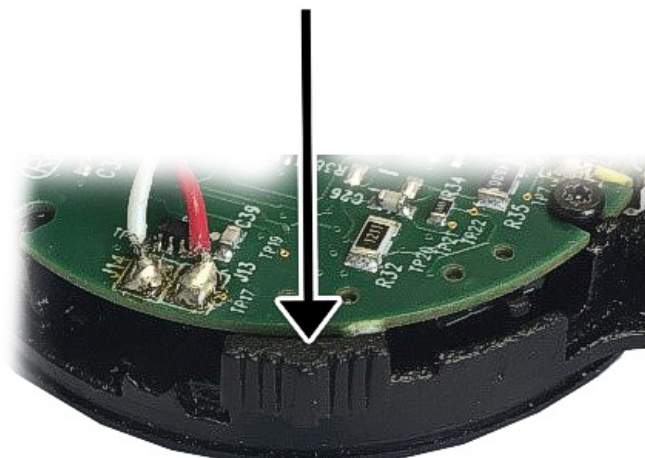
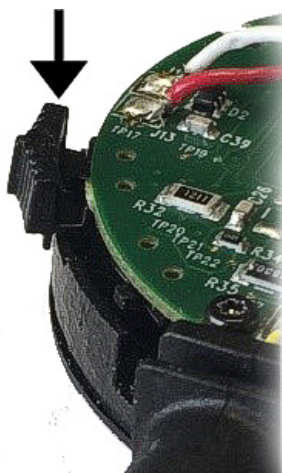

11. Place the **housing on the boom mic assembly**.

**NOTE:** Make sure the overhead cord is in the correct slot and the jacket is fully inside the housing. Also, make sure the headset cord is properly located in the housing.

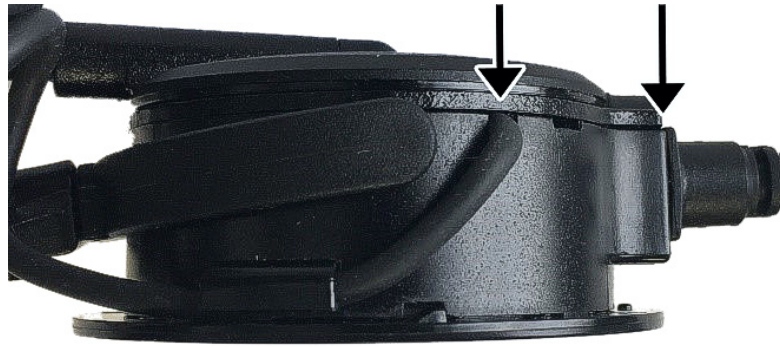

12. Using a T-5 screwdriver, replace the **three screws** (as shown) to attach the yoke and housing to the PCBA.

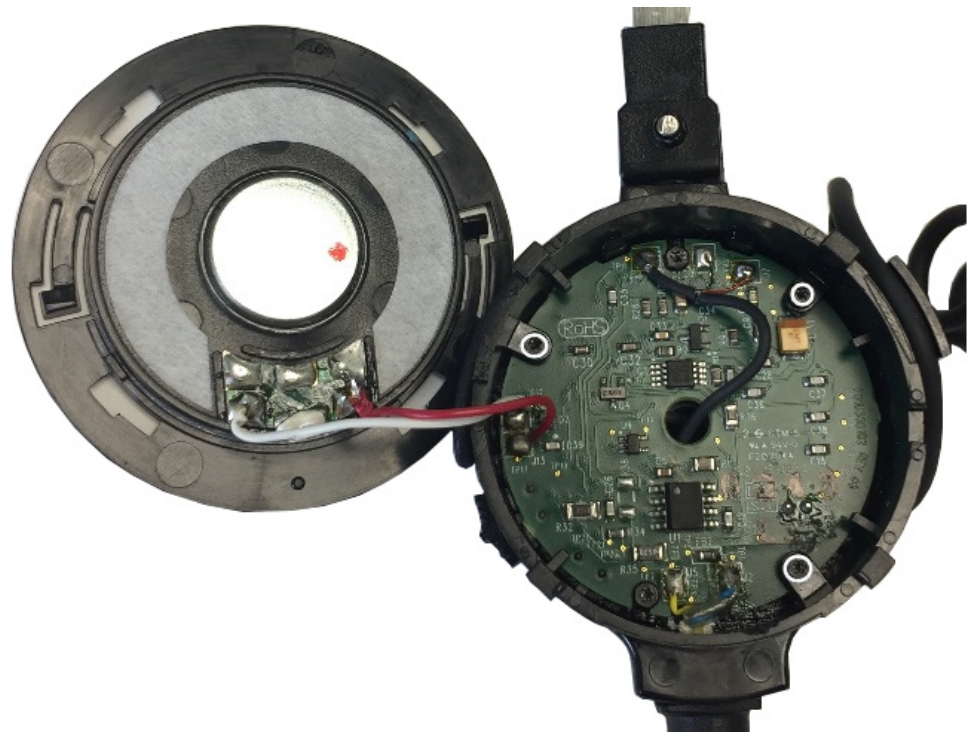

13. Position the **overhead cord** in the **retaining clip**, and then **align the knob of the faceplate toward the bottom**.

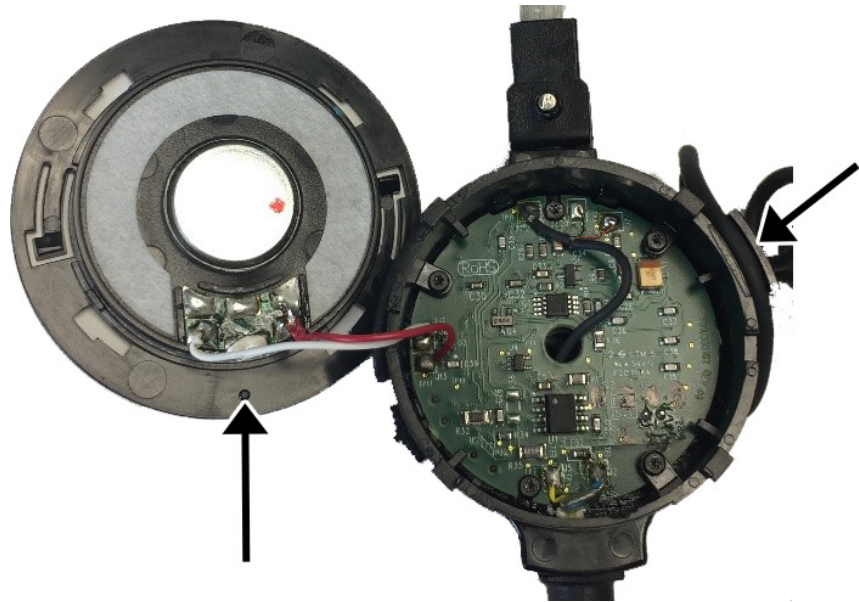

14. Align the **four tabs** on the faceplate, and then rotate **counterclockwise** to lock.  
**NOTE:** Verify all four tabs are engaged and retaining tabs are in the groove.

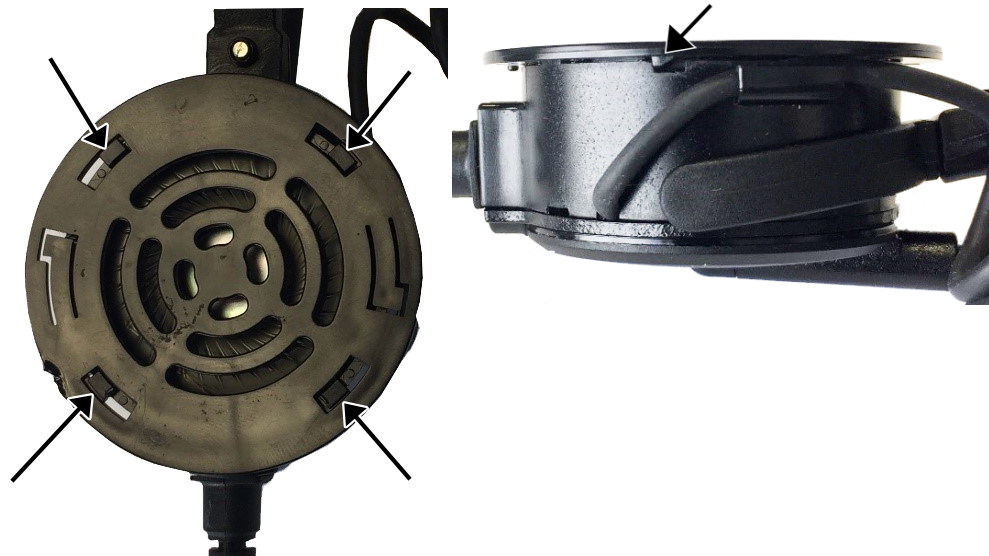



15. Carefully wind the overhead cord around the glider



### 2.3.2.2 Non-Boom Side Assembly

To assemble the non-boom side assembly, do the following

1. Solder overhead cord to PCBA.

J11	red
J12	blue
J9	white
J10	shield
J17	black

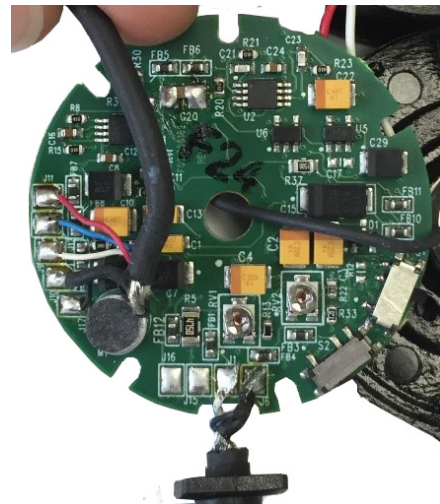

2. Using the two shorter screws, attach the PCBA to the cover (1).

**NOTE:** The location of the alignment posts (1) and the path for the overhead cord (2).

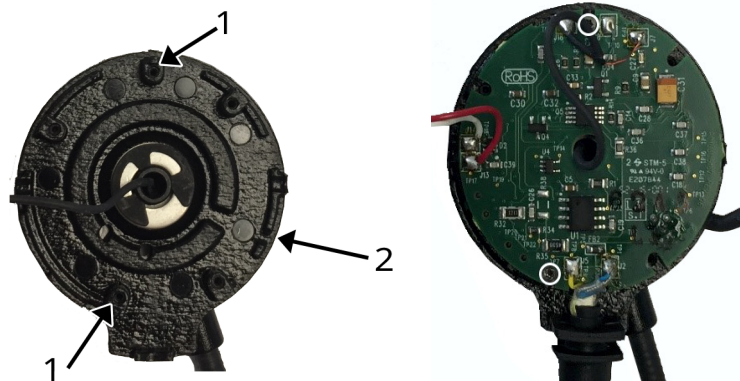

3. Solder the **wires to the speaker**.

**NOTE:** Align the red wire with the polarity dot on the speaker (as shown).

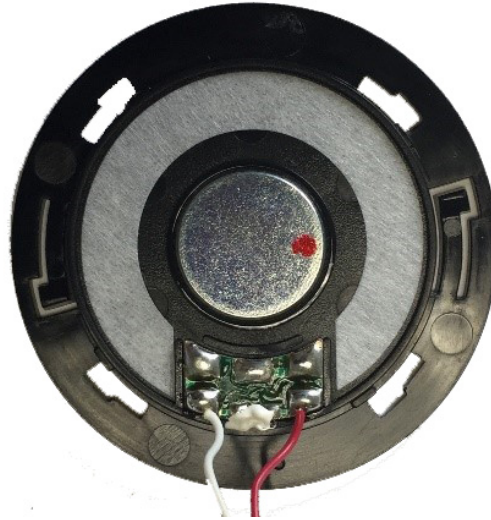

4. Route the **speaker wires through the housing and solder to the PCBA**.

J13	red
J14	white

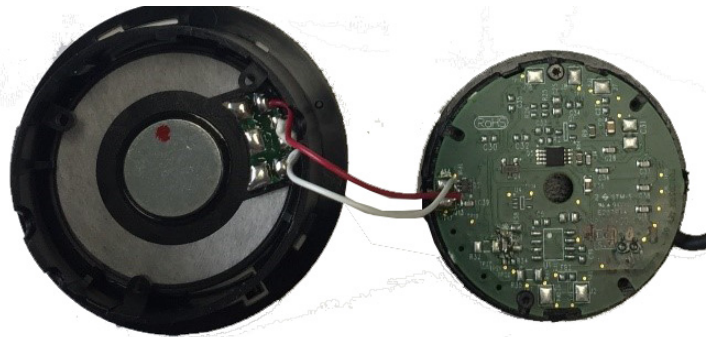

5. Place **yoke** on the housing.

**NOTE:** Take care to verify the orientation of the yoke, because it does not rotate 360°.



6. Place the **housing on the boom mic assembly**.

7. Place the cover on the housing.



8. Using a T-5 screwdriver, replace the **three screws** (as shown) to attach the yoke and housing to the PCBA.

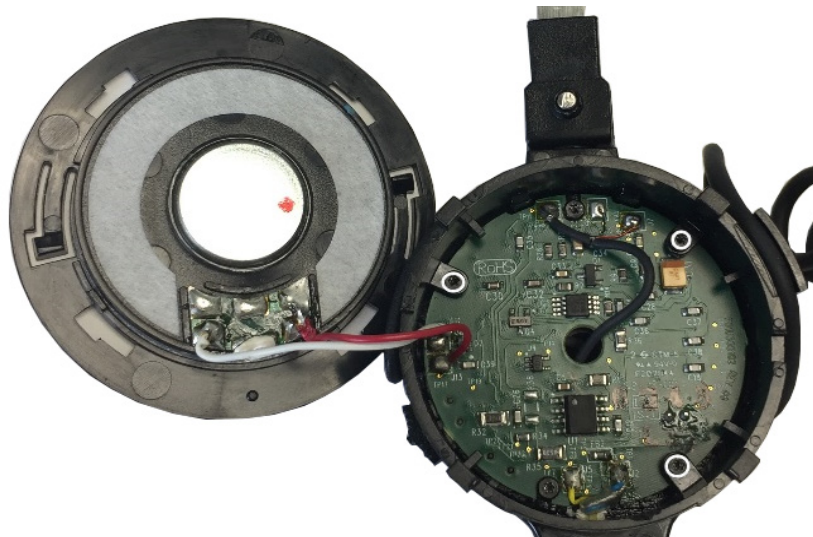

9. Position the **overhead cord in retaining clip** and align the **knob of the faceplate toward the bottom**.

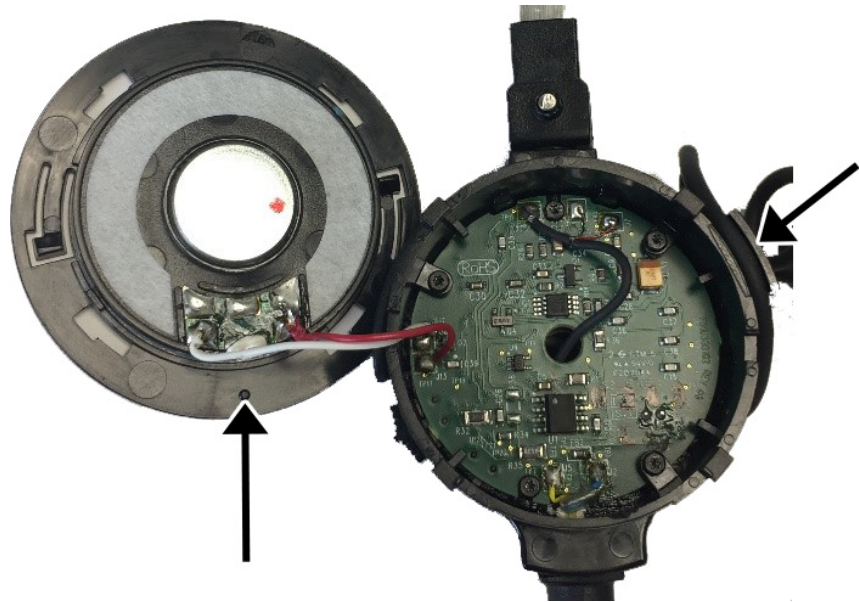

10. Align the **four tabs (shown)** on the faceplate, and then rotate **counterclockwise** to lock.

**NOTE:** Verify all four tabs are engaged and retaining tabs are in the groove.

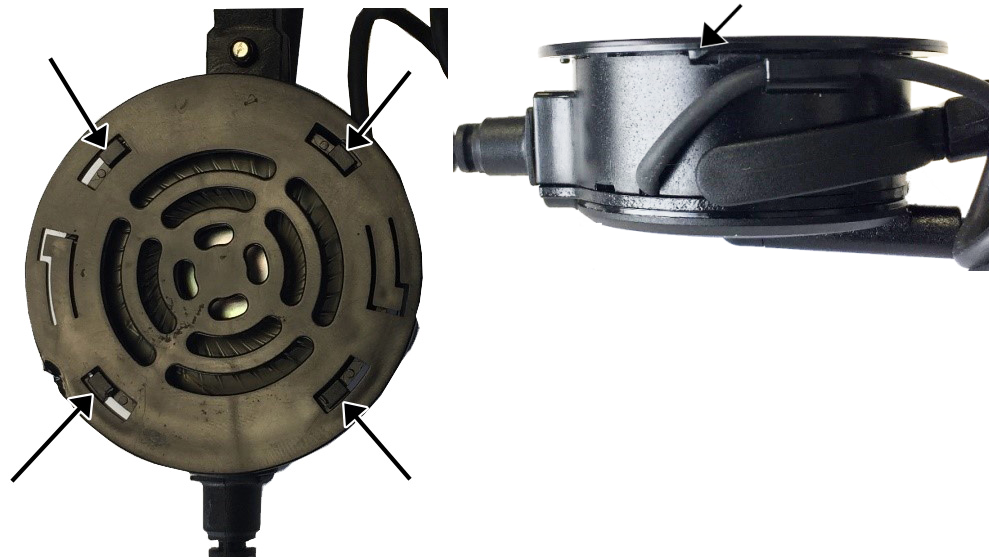

11. Carefully wind the **overhead cord around the glider**



### 2.3.2.3 Attach the mic prefilter

To **attach the prefilter**, do the following:

1. Carefully attach the **prefilter** to the mic.

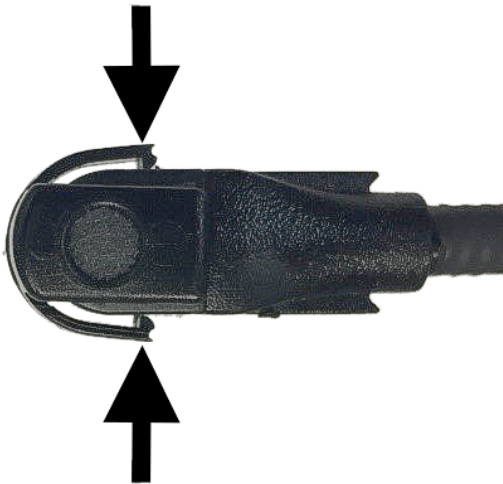

### 2.3.2.4 Reinstall the headband cover

To reinstall the headband cover, do the following:

1. Take care to verify the **overhead cord lays between the guides**.

2. Ensure the cover fully **encloses around the headband at both sides.**

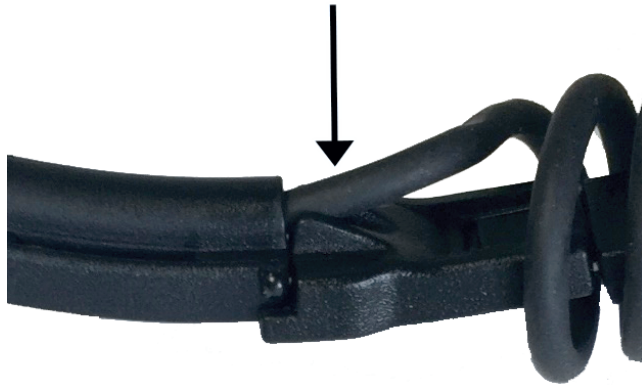

### 2.3.2.5 Replace the Yoke Assembly from the Headband Assembly

To **replace the yoke assembly on the headband assembly**, do the following:

1. Slide the **yoke assembly** onto the headband.
2. Place the **glider stop** in the appropriate hole on the glider.
3. Swivel the spacer in line with the glider, and then **click the bottom edge of the black plastic spacer** into the retaining hole.

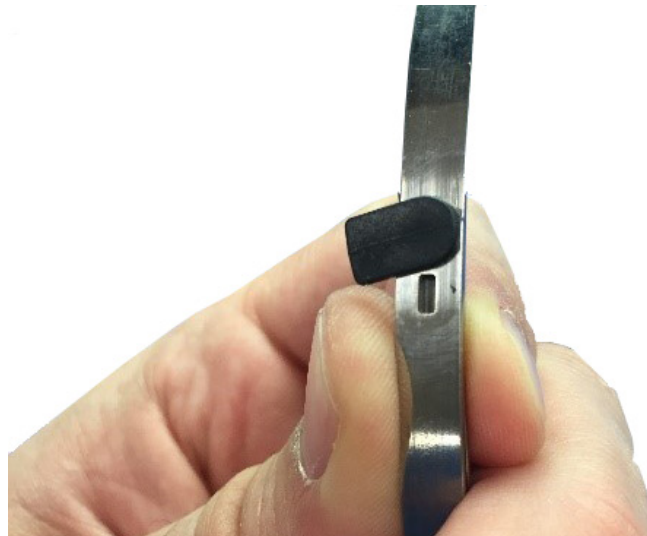

### 2.3.2.6 Replace the headband cover clips (if present)

To replace the headband cover clips, do the following:

1. Carefully snap the clip on to the headband.

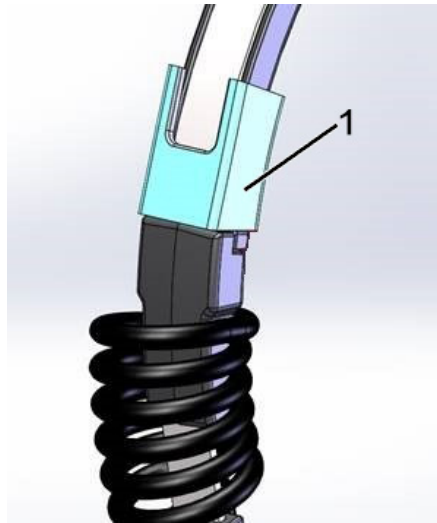

---

**IMPORTANT:** Some headsets a snap feature (2) at each end of the headband cover. If this feature (highlighted in white) is present, the external clips (1) are not used.

---

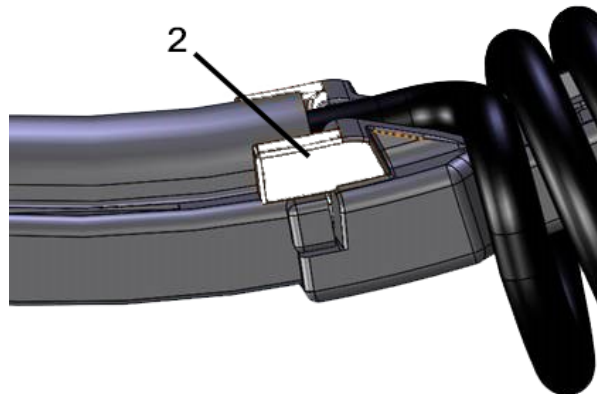

### 2.3.2.7 Replace Cushions and Windscreen

To ensure optimal product performance, it is recommended you replace ear cushions and headband pads periodically (every six months or sooner, if needed).

#### 2.3.2.7.1 Ear Cushion Replacement

To **replace the headband pads**, do the following:

##### Early Version Headband

1. Carefully remove the **headband clips** (see “Remove the headband cover clips (if present)” on page 11).
2. Gently pull the **headband cover away from the headband**.
3. Starting at the either side of the headband carefully work **the replacement cover** around the metal headband until it is in place.

##### Current Version Headpad Holder and Headpad

To **replace the headpad holder**, do the following:

1. At one end of the headpad holder, carefully **pry the holder** from the headband cover.

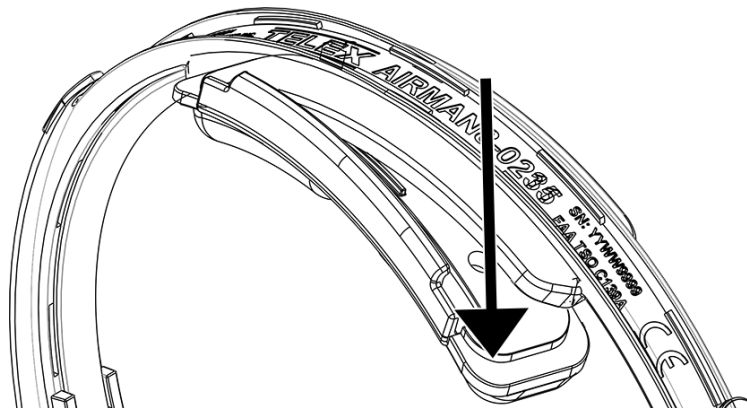

**NOTE:** Carefully twisting slightly on the headpad holder can help remove the piece easier.

2. With the new headpad holder, hook **one side of the headpad holder over the headband cover**.
3. Snap the **other side of headpad holder in place**. Be sure the headpad holder edge is over the headband cover.

To **replace the headpad**, do the following:

1. Grasp the **edge of the headband pad**.
2. Gently pull the **headband pad away** from the headpad holder.
3. Remove the **paper** from the sticky side of the new headband pad.
4. Align the **headband pad** with the recessed area on the headpad holder.



5. Firmly press the **headband pad** into place.

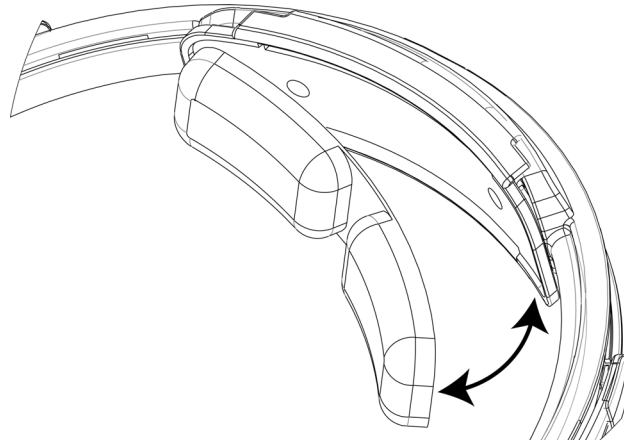



---

**IMPORTANT:** The Airman 8 headset was designed, tested, and approved to FAA TSO C139a. The TSO requires the headset meet the minimum performance specifications as defined in RTCA DO-214a. This document and specifications listed here reference the test procedures and equipment used as defined in these standards. Refer to the standard for details on how to perform individual tests.

---

### 3.1 Troubleshoot and Maintenance

The Airman 8 headset is designed so that ANR performance and boom microphone sensitivity can be adjusted as required to meet specification requirements. These are only adjustments that can be made to the headset in order to alter performance. All other maintenance requires replacement of parts, fixing open wires, or removing shorted wires. See specific instructions later in this section for ANR or boom microphone adjustment.

#### 3.1.1 Recommended Maintenance Schedule

**NOTE:** Ear cushions, headband pads, and microphone wind screens are considered wear items. For proper headset performance, these items need to be inspected and replaced at regular intervals. See the maintenance schedule below for more information. Headset performance diminishes if items are not replaced when deterioration or damage is apparent.

Task	Per Use	Monthly	6 Months
Check Boom Mic Placement	X		
Check Ear Cup Placement	X		
Check Headband Fit	X		
Inspect & Clean Connectors			X
Clean Ear Cushions		X	
Clean Headband Pad		X	
Check Connection Cable		X	
Inspect & Replace Windscreen			X
Inspect & Replace Ear Cushions			X
Inspect & Replace Headband Pad			X

# Basic Inspection

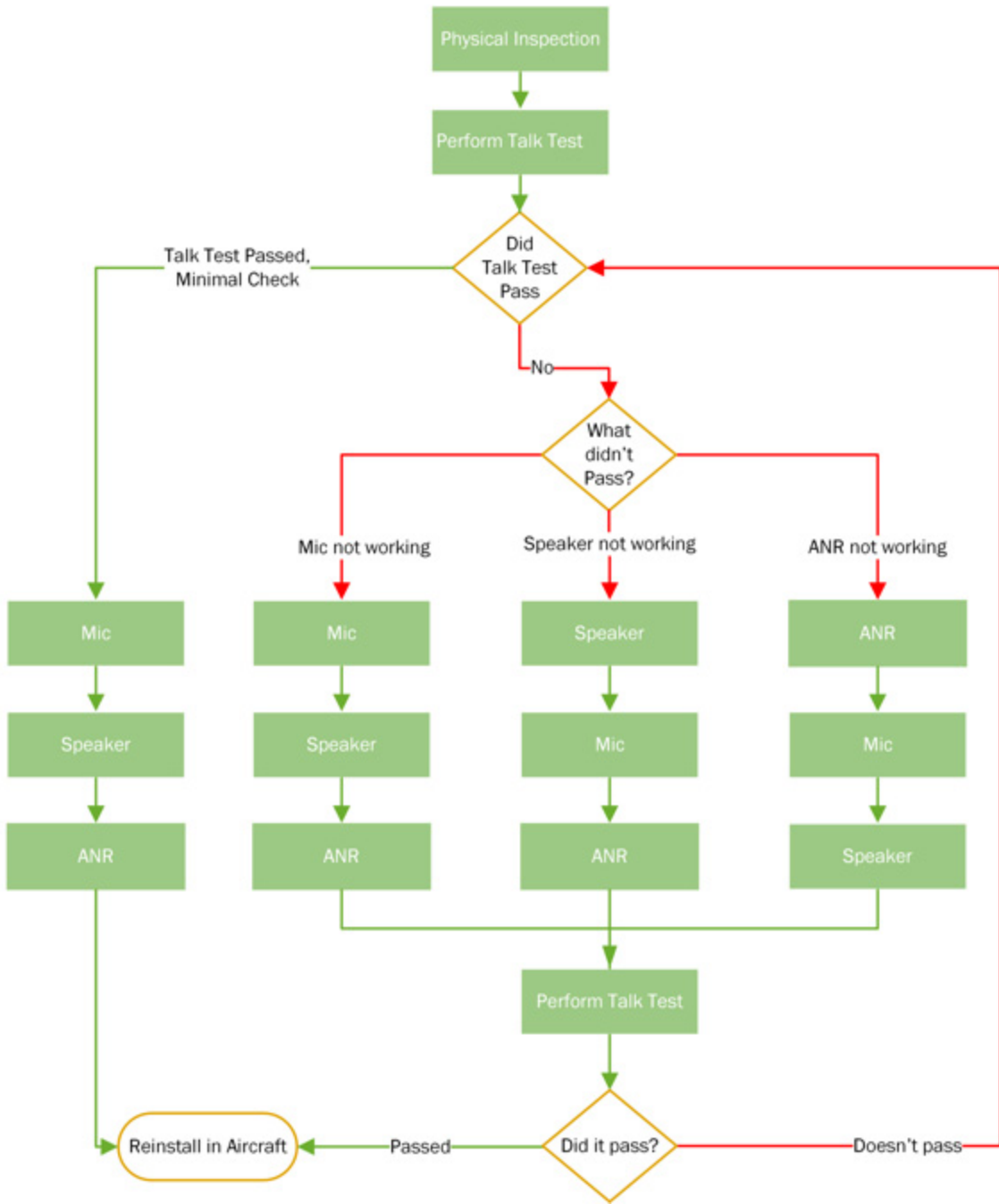

## 3.1.2 Physical Inspection

### 3.1.2.1 Review all plastic parts for cracks or breaks

To **review plastic parts**, do the following:

- Note any parts which need to be replaced

### 3.1.2.2 Review all cables for obvious signs of damage to the insulating materials

To **review cables**, do the following:

- Look for any cables which have been pulled out of the housings.
- Look for any cables with unnatural or unusual bends or breaks.
- Note any cable assemblies which need to be replaced.

### 3.1.2.3 Review user replaceable items

To **review user replaceable items**, do the following:

- Check ear cushions.
- Check headband pads.
- Check microphone windscreen.
- Check clothing clips.
- Note any replaceable items which need to be replaced. Talk Test

## 3.1.3 Talk Test

When performing a talk test, things to be aware of:

- Note any unusual or unexpected noises, static, and oscillations
- Note any distorted audio
- Turn ANR on and note noise reduction of fans, ambient noise etc.
- Turn ANR off and note noise levels return to normal.
- Verify sound is heard in both ears.

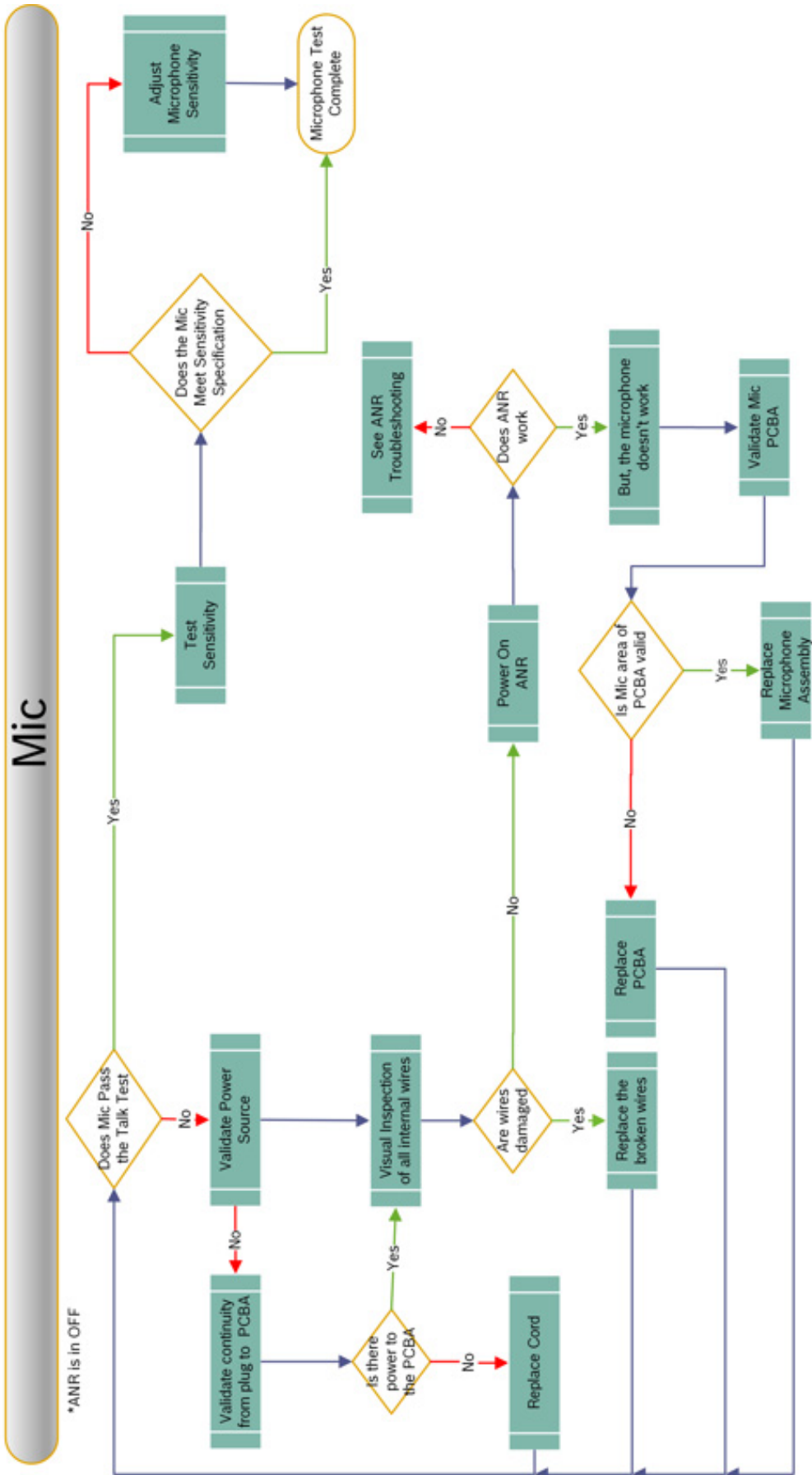

### 3.1.4 Microphone Troubleshooting and Workflow

#### 3.1.4.1 Validate Continuity From Plug to PCBA

To **validate continuity from the plug to the PCBA**, do the following:

1. Using an Ohmmeter, place **one probe on the ring terminal** of the plug.
2. Place the other probe at **J1** on the PCBA.
3. Record the **measurement**.
4. Using an Ohmmeter, place **one probe on the sleeve terminal** of the plug.
5. Place the other probe at **J2** on the PCBA.
6. Record the **measurement**.

*If the reading is approximately 0, continuity is good.*

*If any other reading is seen, the continuity is bad. Replace the cable.*

#### 3.1.4.2 Validate Mic PCBA

1. Construct a **test circuit**.

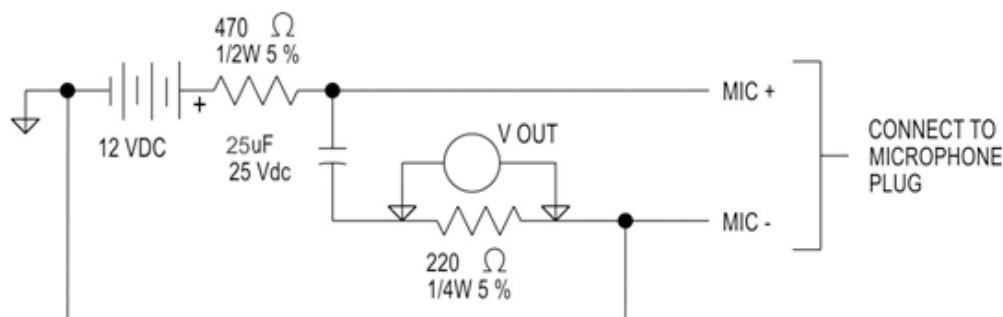

2. Connect the **test circuit** to the microphone plug of the headset.  
*For more information, see "Connectors" on page 50.*
3. Test for **an audio signal**.  
*If audio signal is detected, the board is valid.*  
*If audio signal is not detected, the board should be replaced.*

#### 3.1.4.3 Microphone/Amplifier Sensitivity Check

**IMPORTANT:** The Airman 8 headset was designed, tested, and approved to FAA TSO C139a. The TSO requires the headset meet the minimum performance specifications as defined in RTCA DO-214a. This document and specifications listed here reference the test procedures and equipment used as defined in these standards. Refer to the standard for details on how to perform individual tests.

To **test the sensitivity of the microphone**, do the following:

1. Calibrate an **artificial mouth**.
2. Using the test circuit from the Mic validation and TSO procedures, measure the **output of the headset microphone** with a digital volt meter.

### 3.1.4.4 Microphone Sensitivity Adjustment

The microphone gain has been factory-adjusted to the nominal level required for normal radio operation. Microphone sensitivity is adjusted by turning the gain adjustment control.

To **adjust the microphone**, do the following:

1. Rotate the **boom mic fully clockwise** until the microphone gain adjustment access hole is aligned and open.



2. Insert a **2mm x .5mm flat-bladed screwdriver** into the gain adjustment access hole.

**NOTE:** If gain adjustment access hole is properly aligned, the screwdriver can be inserted approximately 1/2 inch into the hole. If not properly aligned, the screwdriver only inserts approximately 1/8 inch into the hole.

3. Turn the **gain adjustment potentiometer clockwise** to increase the gain.  
OR  
Turn the **gain adjustment potentiometer counterclockwise** to decrease the gain.



### 3.1.5 Speaker Troubleshooting and Workflow

## Speakers – Airman 8

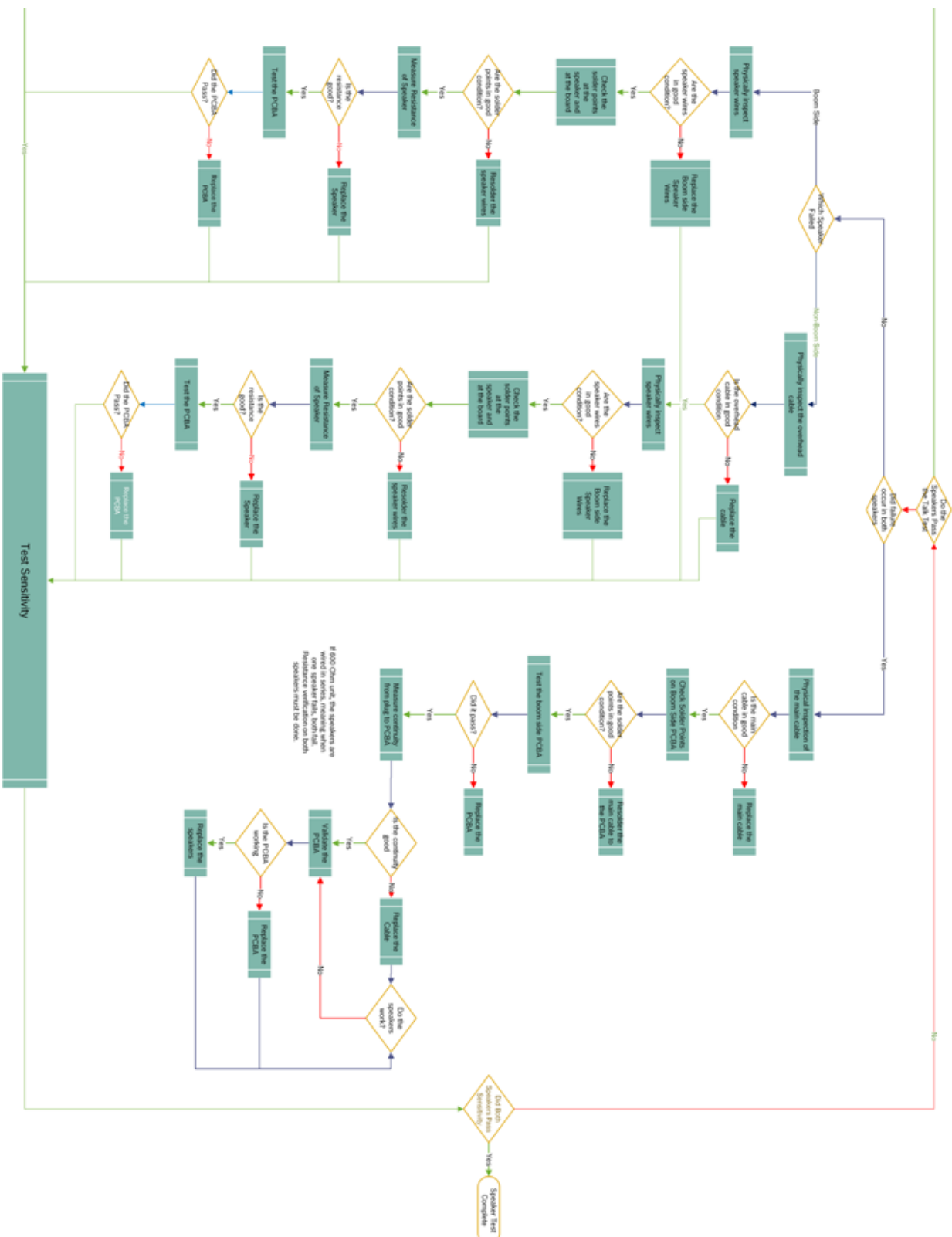

### 3.1.5.1 Speaker Sensitivity and Frequency Response Verification

**NOTE:** The Airman 8 headset was designed, tested, and approved to FAA TSO C139a. The TSO requires the headset meet the minimum performance specifications as defined in RTCA DO-214a. This document and specifications listed here reference the test procedures and equipment used as defined in these standards. Refer to the standard for details on how to perform individual tests.

All models tested, unless noted otherwise.

<b>Transducer type:</b>	Dynamic
<b>Transducer:</b>	600Ω
<b>Impedance (at the earphone plug):</b>	
<b>Sensitivity:</b>	Must meet standards outlined in the specifications table in either the technical manual or the technical data sheet.
<b>Frequency Response:</b>	

### 3.1.5.2 Measure the Resistance (Plug to PCBA)

To **measure the resistance**, do the following:

Using an Ohm Meter, place one probe on **J5** and the other probe on **J6** or **J17**.

*If measured 300Ω ±20%, continuity is good.*

*If measured at 600Ω, one of the speaker paths is defective.*

*If measured at 270Ω or less, there is a short in the speaker path.*

### 3.1.5.3 Validate the Boom Side PCBA

To **validate the boom side PCBA**, do the following:

1. On the boom side PCBA, send a **1kHz sine wave, 1Vrms signal from J5 to J6**.
2. Verify the **ANR switch is in the OFF position**.
3. Using an oscilloscope, place one probe at **J13** and place the other probe at **J14**.  
*If a signal is found, the board is good and if no sound is heard from the speaker, the speaker or wiring is bad. Determine if the speaker needs to be replaced or the wires need re-soldering.*  
*If a signal is not found, the board is not good and should be replaced.*

### 3.1.5.4 Validate the Non-boom Side PCBA

To **validate the non-boom side PCBA**, do the following:

1. On the boom side PCBA, send a **1kHz sine wave, 1Vrms signal from J5 to J6**.
2. Verify the **ANR switch is in the OFF position**.
3. On the non-boom side board using an oscilloscope, place one probe at **J13** and place the other probe at **J14**.  
*If a signal is found, the board is good and if no sound is heard from the speaker, the speaker or wiring is bad. Determine if the speaker needs to be replaced or the wires need re-soldering.*  
*If a signal is not found, the board is not good and should be replaced.*

### 3.1.6 ANR Troubleshooting and Workflow

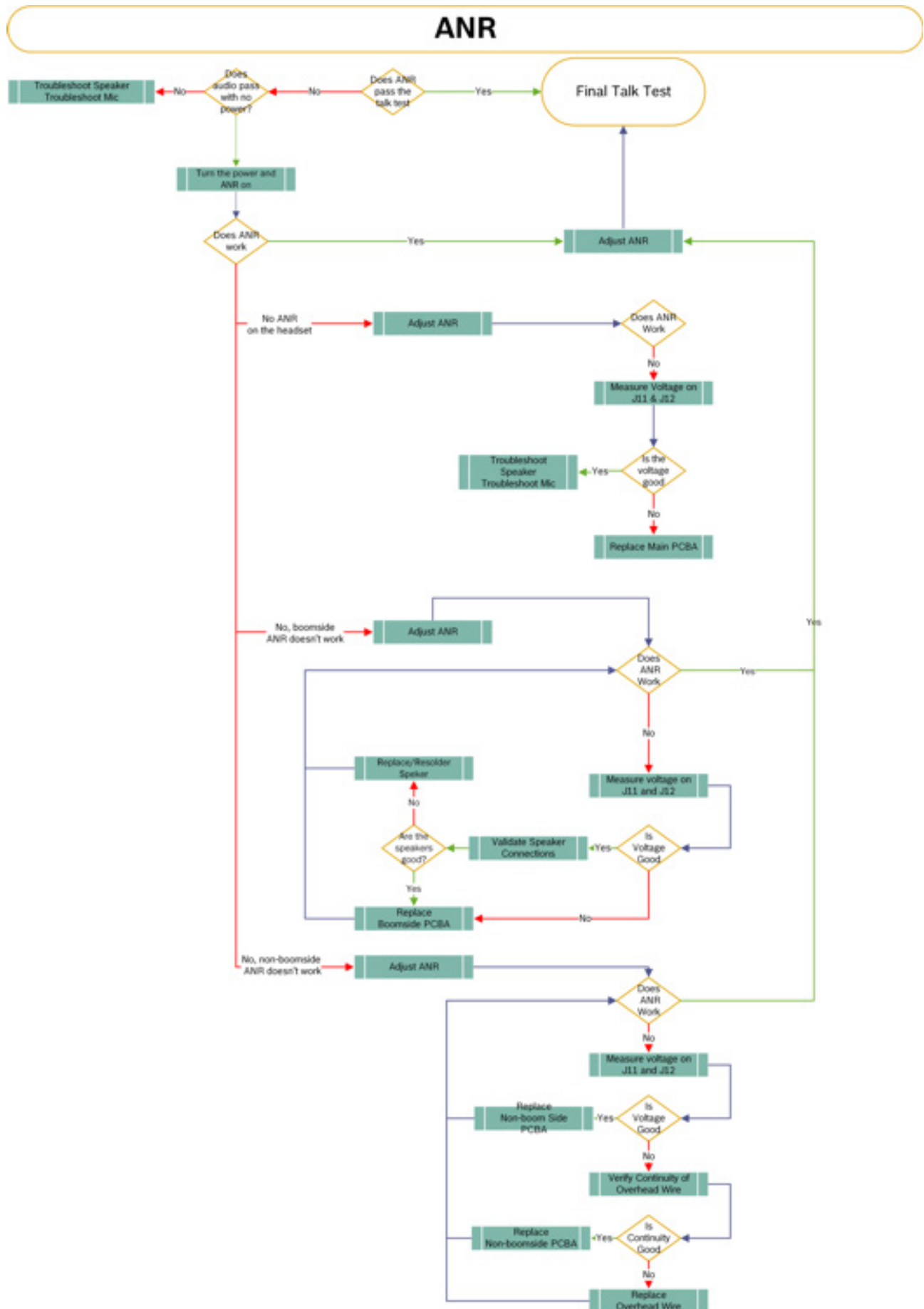

---

**IMPORTANT:** The Airman 8 headset was designed, tested, and approved to FAA TSO C139a. The TSO requires the headset meet the minimum performance specifications as defined in RTCA DO-214a. This document and specifications listed here reference the test procedures and equipment used as defined in these standards. Refer to the standard for details on how to perform individual tests.

---

---

**IMPORTANT:** Minimum attenuation requirements are not requirements of FAA TSO. To achieve the minimum attenuation, Bosch approved test system setup is required.

---

## ANR Test Procedure

### 3.1.6.0.1 Measuring ANR Circuit Voltages and Switch Function

To **measure voltage and switch function on boom-side**, do the following:

1. Verify the **headset main cable plugs are powered on**.
2. Using a voltmeter, place the **ground probe at J10**.
3. Place the **positive probe on TP 14**.  
*If measurement is +3.3Vdc, power regulator is good. If measurement is anything other than 3.3Vdc +/-10 power regulator is bad. Replace the board.*

To **measure the switch functionality on boom side**, do the following:

1. If regulator is good, verify the **ANR switch is in OFF position**.
2. Place the **positive probe at J11**.  
*If measure is near 0, switch is open.*
3. Move the switch to **On position**.  
*If measure is at 3.3Vdc +/- 10%, the switch is good. If measure at any other measurement, the switch is bad. Replace the board.*

To **measure the fail-safe control logic for ANR**, do following:

1. Verify the **ANR switch is in the On position**.
2. Place the voltage meter **probe at J12 on boom-side**.  
*If measurement is greater than -6Vdc the fail-safe logic is working properly. If the measurement is anything below -6Vdc, fail-safe logic is not working, replace the board.*

To **measure the switch and overhead cord functionality on non-boom side**, do the following:

1. If boom-side is good, place the **positive probe at J11**.  
*If measure is near 0, switch is open.*
2. Move switch to **On position**.  
*If measure is at 3.3V +/- 10%, the switch is good. If measure at any other measurement, the switch is bad. Replace the board.*

To **measure the fail-safe control logic for ANR**, do following:

1. Verify the **ANR switch is in the On position**.
2. Place the voltage meter **probe at J12 on boom-side**.  
*If measurement is greater than -6Vdc the fail-safe logic is working properly. If the measurement is anything below -6Vdc, fail-safe logic is not working, replace the board.*

---

**IMPORTANT:** If a board needs replacement due to ANR adjustment, contact Bosch ASA or Bosch certified facility for replacement and adjustment.

---

---

### 3.1.6.1 Cleaning the Headset and Connectors

---

**IMPORTANT:** Do not allow alcohol or any liquid to touch the speaker or microphone element directly.

---

To **clean the headset**, do the following:

- > Using a mild detergent with water and a soft towel, or isopropyl alcohol wipes, **clean the plastic and metal headset parts.**

---

**IMPORTANT:** Do not soak or allow liquid to puddle on the unit.

---

### 3.1.6.2 Cleaning the Ear Cushions and Headband Pads

---

**IMPORTANT:** Do not soak cushions or pads.

---

To **clean the ear cushions and headband pad**, do the following:

- > Using a damp (not wet) soft towel or isopropyl alcohol wipes, **gently wipe the ear cushions and headband pad thoroughly.**

### 3.1.6.3 Replacing Ear Cushions and Headband Pads

To ensure optimal product performance, it is recommended you replace ear cushions and headband pads periodically (every six (6) months, or sooner if needed). See “Ear Cushion Replacement” on page 12 and “Headband Pad Replacement” on page 12.

To **replace the ear cushions**, do the following:

1. Grasp the **edge of the ear cushion** where it folds into the slot on the ear cup.
2. Gently pull the **ear cushion up and away from the ear cup.**
3. Starting at the top of the ear cup (1), carefully work **the cushion** around the cup (2) until it is in place (3).

### 3.1.6.4 Installing and Replacing the Hygienic Covers

**NOTE:** Two hygienic covers are included with the headset. However, extra hygienic covers can be purchased separately.

To **replace the hygienic covers**, do the following:

1. Grasp the **edge of the hygienic cover** where it folds into the slot on the ear cup.
2. Gently pull the **hygienic cover up and away from the ear cup.**
3. Starting at the top of the ear cup, carefully work the cover around the ear cup until it is in place.

### 3.1.6.5 Replacing the Windscreen

The foam windscreen can be cleaned using low pressure air to blow contaminants off from the exterior. If low pressure air does not provide effective results the windscreen should be replaced.

---

**IMPORTANT:** Do not use any liquid on the foam windscreen.

---

To **remove the windscreen**, do the following:

- > Grasp the **microphone windscreen** and **gently pull away from microphone**.

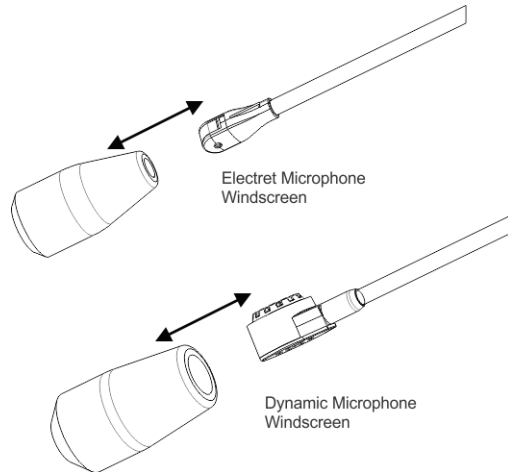

To **replace the windscreen**, do the following:

- > Slide **new windscreen** over microphone.

### 3.1.6.6 Headset Storage

To **store the headset**, do the following:

1. Move the **boom mic** above the headband.



2. Fold the **ear cups flat**.

3. Coil the **cord into a loop**.

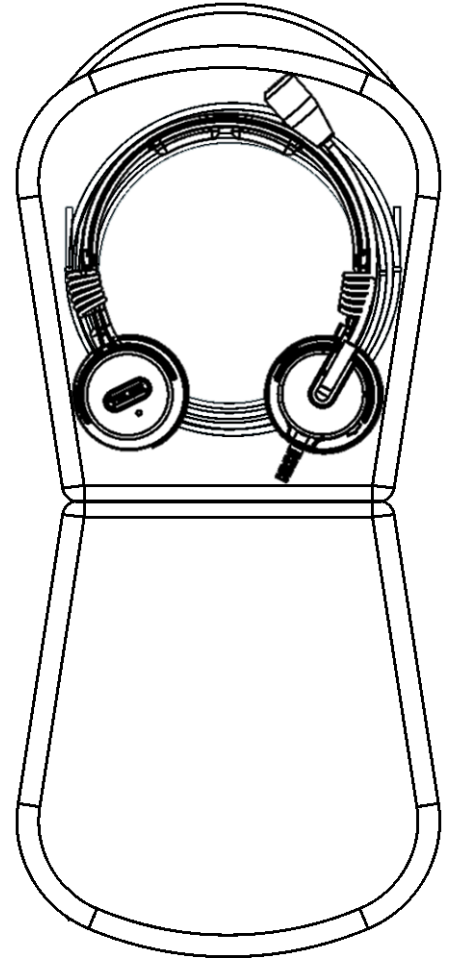

4. Place the **coiled cord and headset** in the carrying case.





# Wiring / Connectors

## 4.1 Wiring Diagrams

### 4.1.1 Wiring Diagram Airman8- 2010 and Airman8-0211

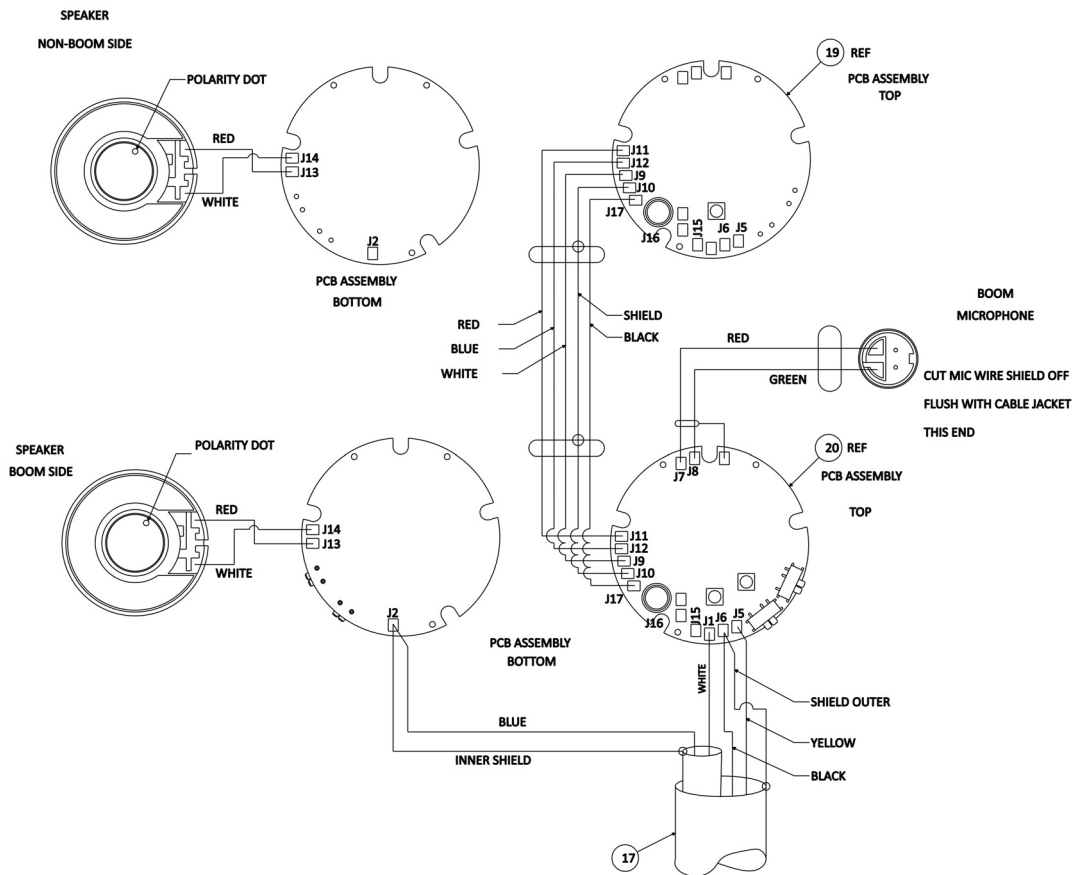

Wire	Notes	Wire	Notes
J15	no connection Outside (mic side)	J6	outer shield + black Inside
J1	white Outside (mic side)	J2	inner shield + blue Inside
J5	yellow Inside	J16	no connection Inside

## 4.2 Connectors

### 4.2.1 PJ-068/PJ055 Connector Diagram for Airman8-0210

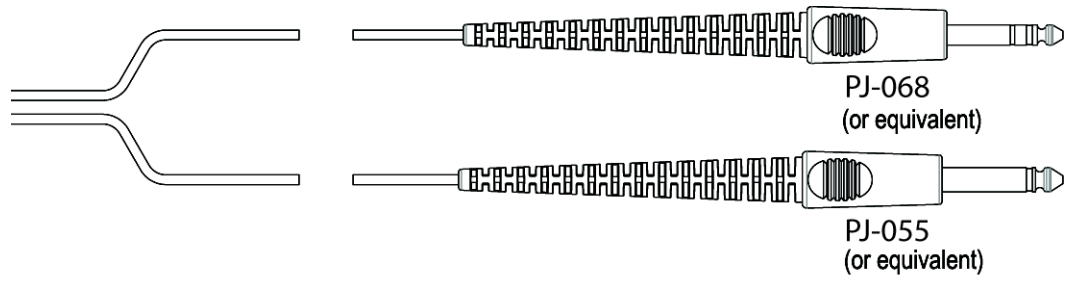

FIGURE 2. PJ-068 and PJ055 Connector Diagram Airman8-0210

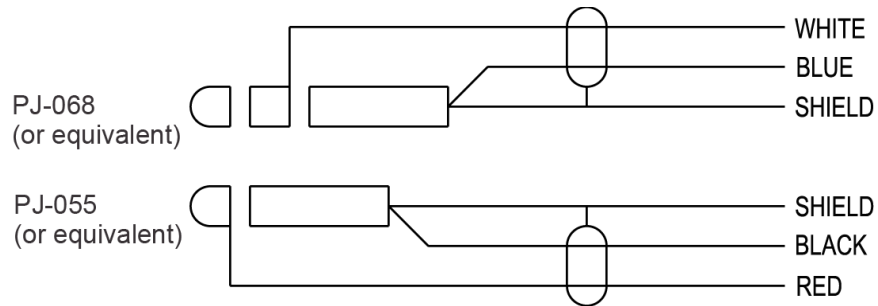

FIGURE 3. PJ-068 and PJ055 Wiring Diagram for Airman8-0210

PJ-068 or equivalent	Description	Wiring Color
Tip	Not Used	
Ring	Mic Signal	White
Sleeve	Mic GND	Blue/Shield

PJ-055 or equivalent	Description	Wiring Color
Tip	Headphone Signal	Red
Sleeve	Headphone GND	Black/Shield

### 4.2.2 XLR Connector Diagram for Airman8-0211

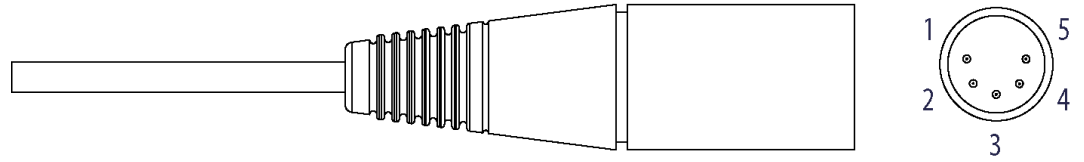

FIGURE 4. XLR Connector for Airman8-0211

Pin	Description	Wiring Color
1	Headphone Signal	Red
2	Headphone GND	Black/Outer Shield
3	Mic Power and Signal	White
4	Mic GND and ANR Return	Blue/Inner Shield
5	No Connection	

---

**Bosch Security Systems, Inc.**

12000 Portland Avenue South

Burnsville, MN 55337 U.S.A.

[www.boschcommunications.com](http://www.boschcommunications.com)