

NOTES: UNLESS OTHERWISE SPECIFIED

1. MANUFACTURED AND INSPECTED IAW AS9100 QUALITY SYSTEM REQUIREMENTS.
2. ABBREVIATION USED IN TITLE IS: VALVE REGULATED SEALED LEAD ACID (VRSLA).
3. SEE DRAWING NO. CB-00450 AND PROCEDURE P-1000 FOR ASSEMBLY AND TEST INSTRUCTION. PROCEDURES AND ASSEMBLY DRAWINGS ARE FOR INTERNAL USE ONLY.
4. BATTERIES ARE RATED IAW INTERNATIONAL ELECTROTECHNICAL COMMISSION STANDARD 60952-1 AND RTCA STANDARD DO-293A, UNLESS OTHERWISE NOTED.
5. DIMENSIONS ARE INCH [MILLIMETERS].

REVISIONS			
REV	DESCRIPTION	DATE	APPROVED
A	ADDED CENTER OF GRAVITY SYMBOLS WITH DIMS	4/13/17	PH

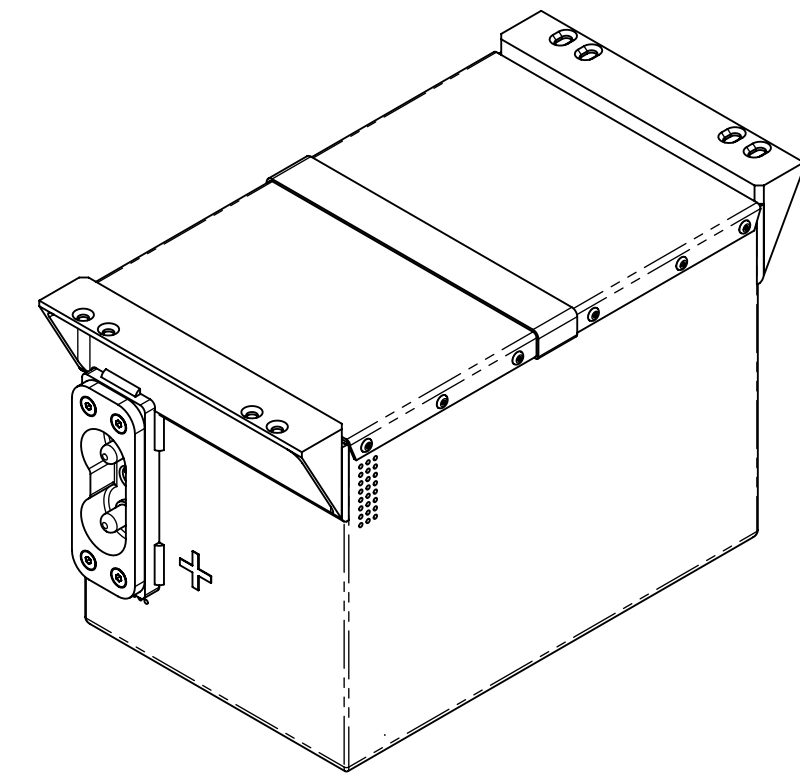
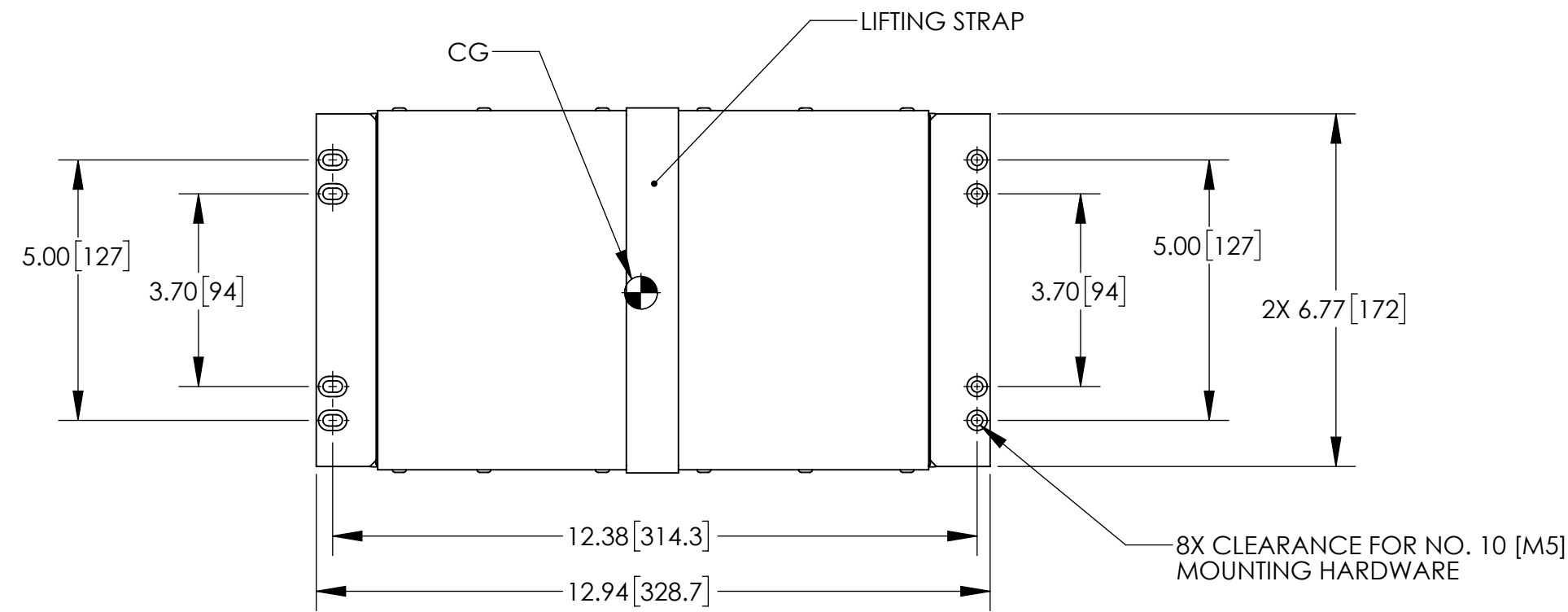

ISOMETRIC VIEW

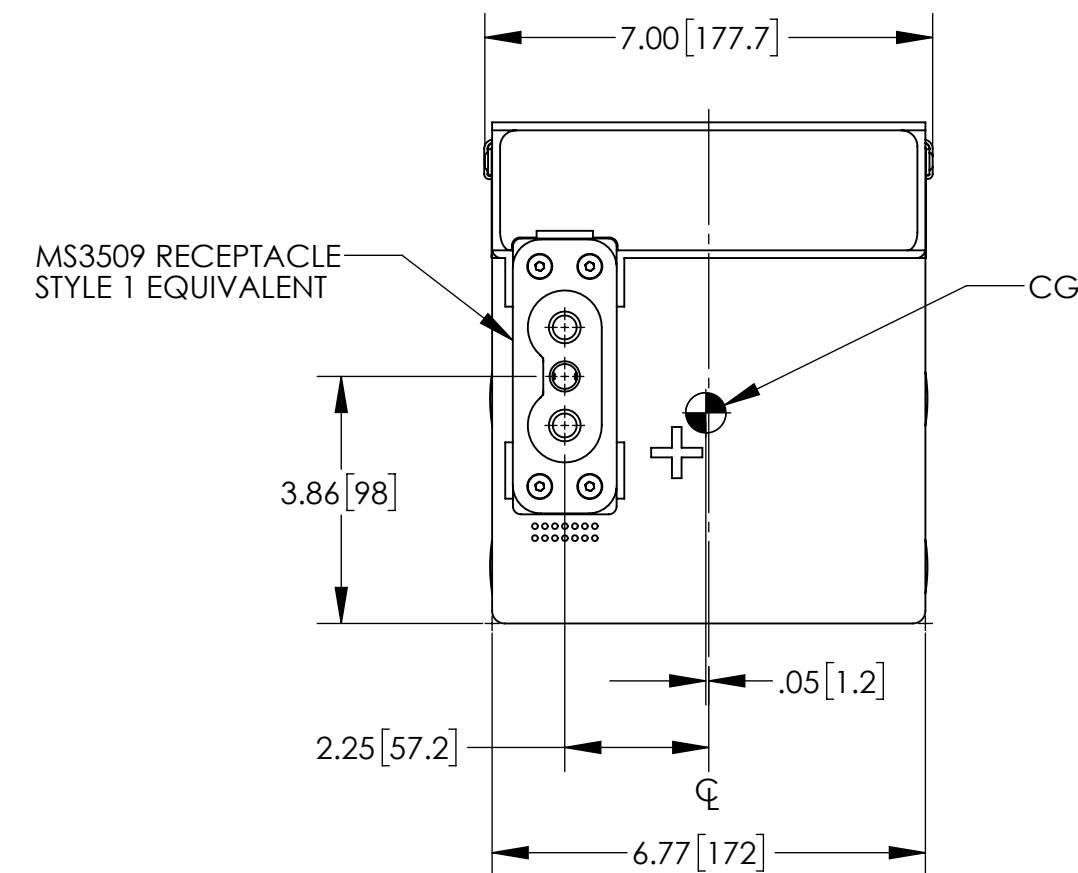
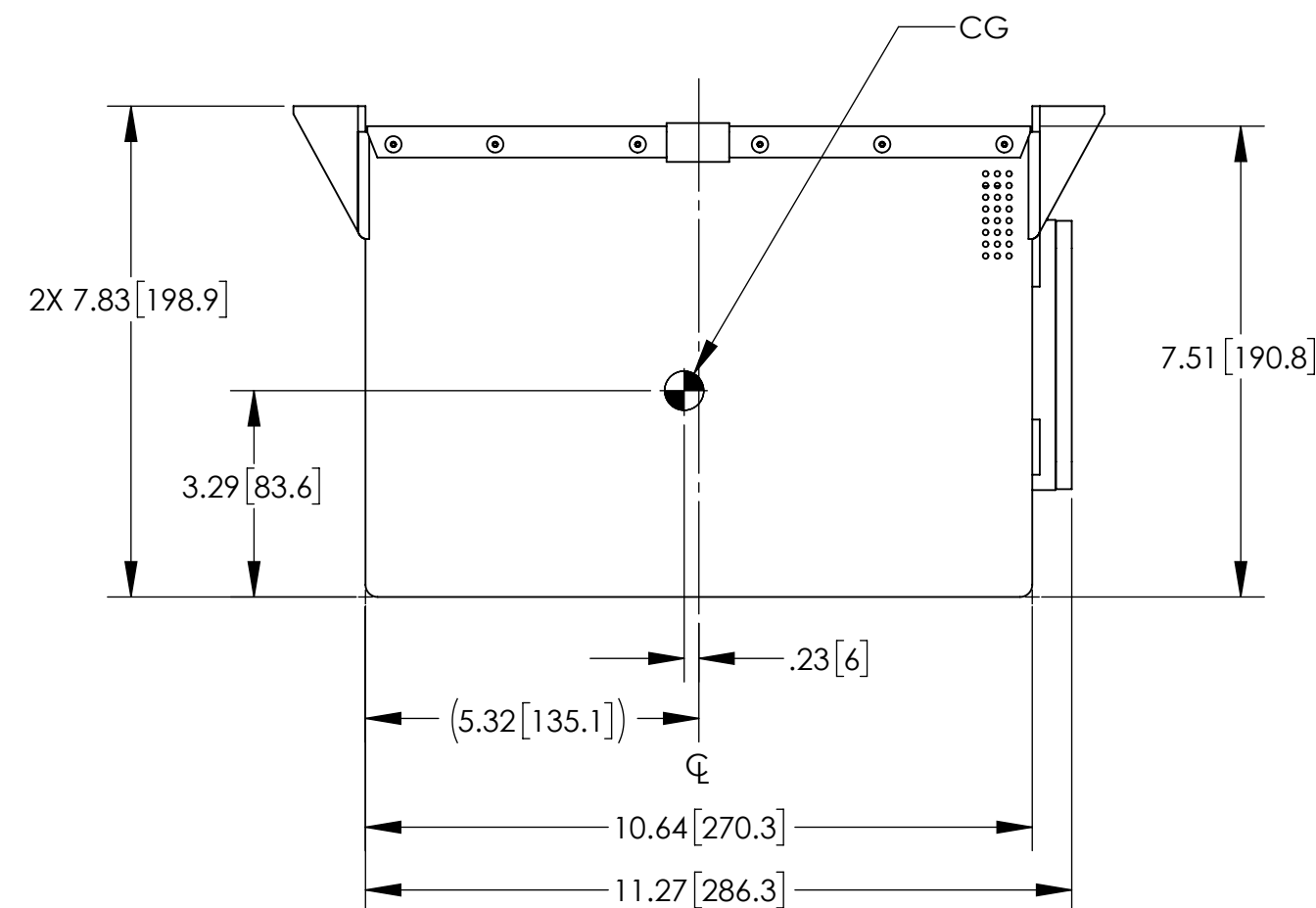

ENVELOPE DRAWING

PART NUMBER	RG-624
MAXIMUM WEIGHT	52 LBS [23.6 KG]
RATED CAPACITY, C ₁	24 AH
POWER RATING AT 23 °C	lpp 1025 A, lpr 650 A
POWER RATING AT -18 °C	lpp 725 A, lpr 500 A
POWER RATING AT -30 °C	lpp 575 A, lpr 400 A

UNLESS OTHERWISE SPECIFIED DIMENSIONS ARE IN INCHES TOLERANCES ARE:			CONTRACT NO.		CONCORDE BATTERY CORPORATION 2009 SAN BERNARDINO RD, W. COVINA, CA 91790		
FRACTIONS	DECIMALS	ANGLES	APPROVALS	DATE	TITLE		
±1/32	.XX ± .06 .XXX ± .030	±1	DRAWN	A. MISTRETTA	5/3/16	BATTERY, VRSLA, 24 VOLT	
TREATMENT	NONE	CHECKED	NS	10/7/16	SIZE	CAGE CODE	DWG NO.
FINISH	NONE	APPROVED	PH	10/10/16	C	63017	RG-624
SIMILAR TO	CALC WT	ISSUED	JG	4/13/17	SCALE	1:3	SHEET 1 OF 1