

Part # 45

The Pros and Cons of Oil Injection

by Mike Stratman

A great debate has begun to rage, fueled by bad information, about the pros and cons of fuel injection. These new systems make premixing and ratio figuring of two cycle lubricants a thing of the past by automatically injecting the oil from a separate reservoir. Most new engines from Rotax include an oil injection system, a rather expensive option, for some very good reasons. This month we'll take an in depth look at oil injection. Why it's included, how it works, how to set it up properly including reservoirs and cabling, and the advantages you can expect from the extra hardware.

Oil injection is not something new, it has been used on two cycle engines since the early 60's. It is currently being produced in excess of 200,000 units for use on different engine applications over the last five years. Oil injection was first introduced on the Rotax 582 in 1989, so it is not something new or untested.

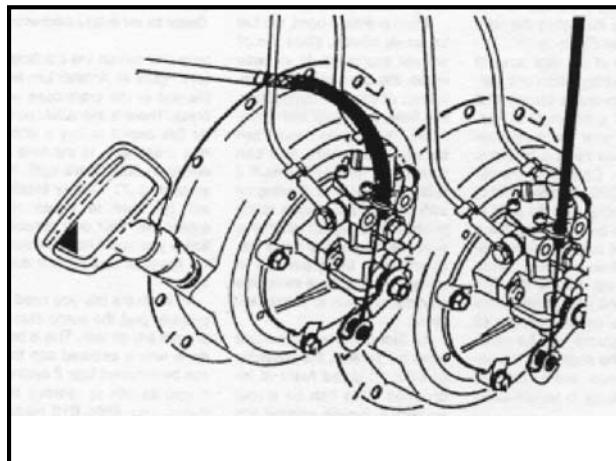

Figure #1 - The oil injection pump must be linked to the throttle opening to regulate the oil flow versus the engine's rpm.

What is Oil Injection and Why is it Standard Equipment: Oil injection has the ability to regulate the flow of oil to the engine by rpm range from a dedicated reservoir. The pump is gear driven and regulated by separate throttle type cable. Below 3000 rpm the ratio drops to 70 to 1 or less. This has the ability to reduce exhaust emissions considerably. Two cycle engines are not exactly the cleanest burning type of motor. They are basically dirty little engines that

sacrifice combustion efficiency for simplicity and lightweight. In many regions they do not meet US Clean Air Standards for exhaust emissions.

The use of oil injection has enabled manufacturers to receive special exemptions from these standards, prolonging sales exclusion in some US States. The day may be growing near where even this will not satisfy the bureaucrats.

You may be dealing with catalytic converters at some future date, not exactly something to look forward to!

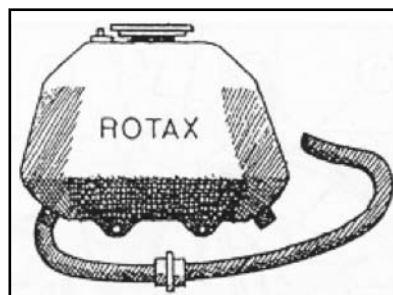

Figure #2 - Rotax part # 881-465 is a factory oil reservoir that includes mounting hardware to locate the unit right off the head studs. Also includes a low level sensor that lights a dash idiot light.

What Are The Advantages Of Oil Injection?: In order to understand the advantages you need to know some of the drawbacks of pre-mixing at 50 to 1 only. All pre-mix engines have a tendency to over lubricate at the low throttle area. The problem stems from the propeller loading being very light and the engine not needing a 50 to 1 ratio. There is no real "work" being done. The engine will also be in a fuel rich state to allow for easier acceleration into the mid and high ranges since we do not have the advantage of an accelerator pump. There are other several problems can be expected. Internally the engine will trend toward premature sticking of the lower ring when run at low RPM's for extended periods. Extensive idling will also create excessive carbon build-up requiring a shorter decarbon period. Also the exhaust output will usually supply the prop and nearby sail cloth with a nasty black spray that is nearly impossible to remove without harsh chemicals. Spark plugs also take a beating at the lower RPM's. You can expect to replace plugs more often with pre-mix engines.

How Does Oil Injection Work?: Oil from a separate reservoir is injected into each intake manifold directly after the Carburetor using a gear driven pump. The pump is governed by a regulator arm that linked to the throttle opening with an additional cable. See Figure # 1. When properly adjusted the pump drops the ratio to 70 to 1 or less below 3000 rpm. Over this rpm the oil injects the standard 50 to 1 or 2% mix. This requires some special hardware when setting up the system. The remote reservoir must be located at a higher or gravity feed position in relation to the pump. The pump does not have the ability to pull the oil from a lower position. This requirement is a potential problem in some aircraft designs and some OEM's will have the

builder disable the system and go pre-mix. Not hard to do if you know how. More about this a little later.

How To Set Up An Oil Injection System: As already mentioned, the oil reservoir must be mounted so that the lowest point in the tank is above the pump. Several reservoirs are available from around \$12 to well over \$100. What is most important is make sure that the size, position, and visibility of the reservoir is both adequate and easy to monitor. What you have to fully realize is that if this tank goes dry you will be looking at cooked Rotax unless you are quick to see your CHT go ballistic. A white plastic

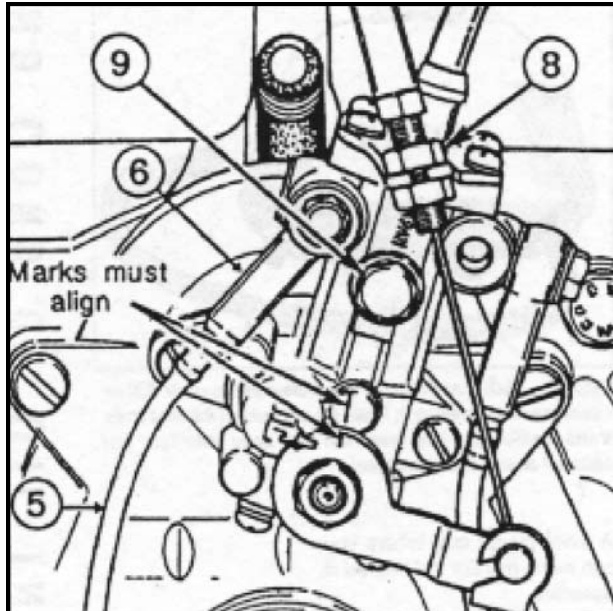

Figure #3 - The mark on the pump arm must be aligned with the cast mark at around 3000 rpm.

tank where you monitor the oil level easily is essential. The theory that bigger is better making refilling infrequent may not be best. This may give you the false security that you may not fill the tank whenever refueling. Rotax makes a 2 liter white plastic reservoir that includes a low level sensor that lights a dash "idiot" light. It mounts either on the firewall or right off the head studs on the liquid cooled motors. See Figure #2. This takes care of the gravity requirement nicely. An oil filter is included with this system as well, a requirement regardless of what is used for a reservoir. The unit also has a low level sensor that actuates a red dash light (not included) to warn the operator with plenty of reserve.

Once you have the tank in place the pump requires a "Bowden" or throttle cable to actuate the regulator arm. As always, Rotax includes no throttle or oil pump cabling with new engines. This is best done with a dedicated cable working in unison with the throttle wire(s). A triple splitter junction block is the easiest way to accomplish this. With the use of a single cable from the throttle handle the triple junction block moves all three cables in unison. When properly adjusted the cable will allow the marks on the arm and the pump to pass at around 3000 rpm. The engine's operators manual does a good job of illustrating this relationship. See Figure #3. Because of the vast array of engine mounting situations, getting custom made cables that provide for a minimum of spaghetti for your particular application has been a problem. This year CPS has installed a lot of custom tooling and did a lot of research to be able to provide a huge selection of custom cabling options. See Figure #4. Because engines mounted inverted or plugs up require different cabling. While the carburetors are always pointed up, the oil injection pump will be positioned as the engine is. This requires even more special cabling options to handle every situation. Another thing to note that the regulator arm on the liquid cooled motors

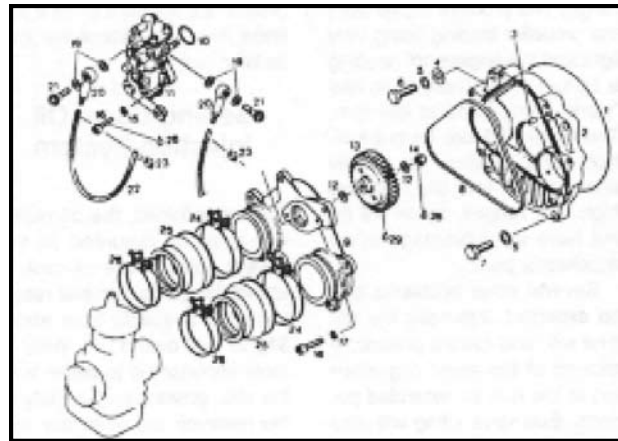

Figure #4 - Due to a vast array of engine mounting situations the '95 CPS Catalog includes dozens of cabling options such as you see here.

and the 503 are not the same requiring different size cable end barrels. CPS also offers custom cables made to the customer's specifications for obvious reasons. Even with a dozen or so options in our '95 Catalog, it is not possible to anticipate every situation.

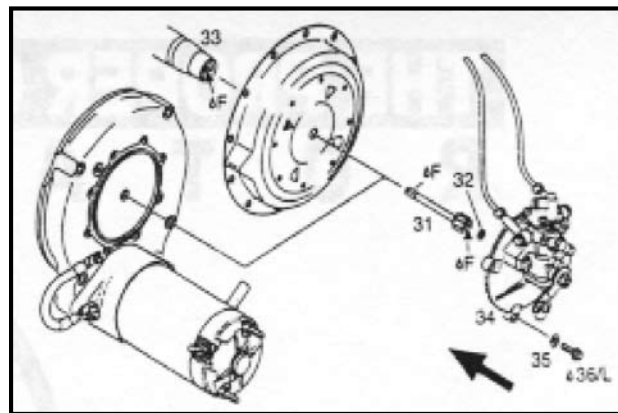

Figure #5 - So disable the oil injection system it is best to remove the white plastic gear. Extreme care must be taken when reinstalling the RV Cover Pate. Consult the text or risk a costly error.

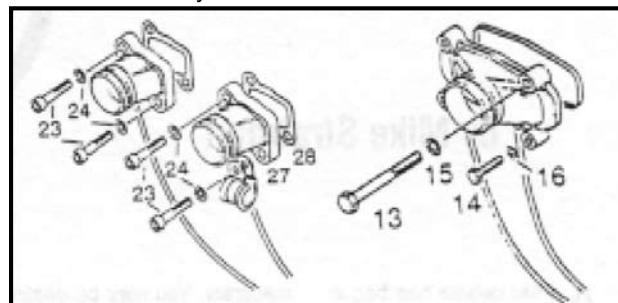

Figure #6 - On all new Rotax 503's the crankshaft end is modified to accept the oil pump drive gear. The pump is mounted on the starter cover as shown.

What Are The Advantages Of Pre-Mix?: We already discussed the drawbacks of running pre-mix so you have a good idea of what you will be dealing with when using pre-mix. Simplicity is the main argument for pre-mix. No special cabling, reservoirs, and added expense. In some applications the added weight could also be an important consideration. These include a Part 103 Ultralight or racing applications where the extra weight may not be a part

of the equation. In racing applications the time spent at idle is considered minimal. It is quite common to see racing applications running pre-mix for these reasons.

How Is The Fuel Effected By Either System: Fuel plays an important role in how well an oil injection or premix engine will work. When fuel is left in storage, evaporation and octane bleed off occurs. This evaporation can cause detonation due to insufficient octane. This can cause intense heat and eventual penetration of the piston dome especially in higher compression engines. See Part #27 "Blown Pistons Tell the Story". When premix is used fuel becomes oil-rich since the oil will not evaporate. In extreme cases this can result in contamination of the fuel tank, filters, fuel lines, fuel pump, and carburetors. This varnish deposit can be extremely hard and can cause fuel flow problems if left to build up over time. Starting off with the highest octane rating available (usually 92 octane) is essential if you are not a frequent flyer. Long periods in storage are therefore more of a potential problem in premix engines.

As fuel becomes more and more oxygenated the possibility of ethanol laced fuels is increased. This can be a real problem in two cycle engines and should be avoided if at all possible. See Part # 37 "The Good, The Bad, and the Ugly of Oxygenated Fuels". Oil injection is preferred when fuel containing ethanol is used since the "blending" is accomplished in the turbulence of the incoming fuel at the latest possible instant before combustion. Direct competition of the alcohol and the lubricate can lead to big problems in ring fouling. This is, of course, not possible in the oil injection engine.

What To Do If You Want Disable The System: In these cases it is best to disable the oil injection system properly. On the liquid cooled engines you have to remove the large white plastic gear just inside the Rotary Valve cover plate assembly. This is a fairly simple job requiring a minimal selection of metric sockets. Two things to be aware of when doing this work. First, be sure to not disturb the rotary valve plate when removing the RV Cover assembly. If you remove the plate it will have to be retimed. See Part #30 "The Final Teardown". of "The Proper Care & Feeding of the Rotax Motor" for proper RV plate timing. Also be extremely careful when reinstalling the 8mm bolts holding the RV Cover. If the longer of the two size bolts are installed in the wrong location they will go thru the boss and contact the crankcase. See Figure #5. Another turn and the ear of the crankcase will break. There is absolutely no fix for this except to buy a whole new crankcase to the tune of nearly \$1000!. That's right!, no amount of JD Weld or brazing will be able to repair the crankcase. Your only consolation being you would not be the first poor soul to do this. To finish the job you need to properly plug the pump inlet to prevent any air leak. This is best done with a secured cap that can be removed later if desired. If you decide to remove the pump, use #860-610 rubber caps to plug the intake manifold ports. These are the same caps supplied with Bing Carbs to cap the primer port when not used. However you choose to plug the potential air leaks include them in your daily pre-flight checklist.

On the Rotax 503 the pump is driven from a special gear shaft that runs off the magneto end of the crank. To disable remove the starter cover with pump and slide this gear from the end of the crank. Engines with oil injection will have a special crank that is modified to accept this drive gear. See Figure #6. All Rotax 503's after serial #4103549 include cranks that are oil injection ready. The intake manifolds are also modified with special ports to inject the oil properly. See Figure #7. These ports can be capped with the same #860-610 Rubber Cap is necessary.

Other Things To Know About Oil Injection: Contrary to some misleading information being circulated, oil injection failures are extremely rare. It is true that some types of two cycle lubricants using a high viscosity or molasses type formula cannot be used with oil injection pumps. I find it more than just coincidence that the same people promoting this type of oil are the same suppliers that are claiming "multiple failures", "just too many moving parts" and encouraging customers to remove their oil injection. A classic case of buyer beware. The fact of the matter is that there is a far higher rate of failures associated with blown ratios, "I forgot to add the oil", "Sorry, buddy.....I didn't know this was a two stroke!?", and other operator blunders when running premix.

When running oil injection a lot of people prefer to run the first tank of fuel on a new engine at 100 to 1 premix as well. This does two things. Any air in the system has time to be purged plus there is some extra oil available to flush the break-in material from the piston rings. Subsequent small bubbles in the delivery lines are passed easily and are no cause for alarm.

Conclusions: As you can see both systems have advantages and drawbacks. For reasons outlined earlier, oil injection is a necessity that will be included on most new model engines in the future. Economically it is safe to say that retrofitting an older premix engine with oil injection is probable cost prohibitive. As with many decisions on aircraft, there are compromises to be made. Knowing the pros and cons should make your decision one you can feel confident with.