

# Part #50 – Curing Rotary Valve Shaft Problems

By Mike Stratman

You doing your regular preflight and everything is looking good. You remove the cap from the RV Fluid reservoir and here's water mixed with the fluid! Where did this come from!!!!? Can I still fly with it like this or am I grounded!!!!? Unfortunately this scenario is not that uncommon. Problems associated with the RV Shaft have been the subject of countless production changes, tons of hangar talk, aftermarket fixes, and general hair pulling. This month we'll look at the problems and solutions for the premature failure of the Rotary Valve / Water Pump Shaft Area. We'll outline what's needed to do repairs and reset the timing plate. We'll also discuss the things to do to make sure your next fix takes you to TBO and beyond. Surprisingly enough the fix is a fairly simple one arrived at after much trial and error.

**What are the signs to look for and what causes this failure:** On all liquid cooled Rotax there is a shaft that runs perpendicular to the crankshaft. This shaft has two functions. The intake side runs the rotary valve plate that acts as an intake valve that times the gases entering the lower crankcase. The other end runs the water pump impeller. In between is a cavity that contains a brass running gear that works at 90 degrees to the crankshaft. This area needs to be lubricated by lightweight gear oil. With few exceptions the same fluid used to mix with the fuel is used in this bath reservoir. The shaft seals that separate this cavity from the water pump are where most of the failures occur. Commonly the seals will cut the shaft causing an exchange of fluids. Because the coolant system works under pressure, the coolant will be forced into the RV cavity. In excessive cases the coolant will also be contaminated with the RV fluid. If left long enough the coolant will turn to "milk" with the RV fluid thoroughly mixed into the coolant.

**What causes this to happen:** Originally the causes were not obvious. Smaller shaft diameters (reducing speeds between shaft and seals) were tried with inconsistent success. The hardness of the shaft was changed, again with mixed results. Soon the coolant itself came under suspicion. Test showed that the minerals in tap water were being attracted to the friction between the shaft and seals causing an abrasion to set up. This abrasion would actually cut the shaft causing the exchange of fluids. Distilled water mixed at 50% with coolant showed much improved longevity. But even this did not take the parts to overhaul time. More about this later.

**Production Variations:** In an effort to solve the shorten life span on these parts the factory made a number of changes. First, way back in the 532 series engines, the shaft diameter was reduced from 12mm to 10mm to reduce the speed on the shaft and seal. This required the shaft and the seal to be changed. 10 years and factory replacement parts makes running into this 12mm set-up extremely rare. The major changes can when the weep hole or witness passage was plugged off. A passage cast into the crank allows for the vented of the gap between the two facing seals directly behind the water pump impeller. Once either of the seals failed a fluid drip would signify which seal had failed. Unfortunately some operators would mistake this for a water pump housing gasket or crankcase leak and start torquing the water pump bolts or replacing the gasket. This of course did nothing to stop the leak and often times resulted in stripped threads in the crankcase. The photo in Figure #1 shows the passage with a setscrew plug. You can do this yourself with the right size set screw and a little tap and thread savvy. See figure #1



Figure #1 – A setscrew plugs the cast passage in the upper case half that leads to the area between the two shaft seals. See arrow for setscrew.



Figure #3 – Removing the RV Shaft can be done with the engine still in the aircraft in most cases. Rotax Tool #876-612 threads nicely onto end of the shaft.

The setscrew plug also made it necessary for both seals to fail before there could be an exchange of fluids. But the cavity **must be** filled with a lithium or silicone grease to prevent thermal expansion. I have personally seen the seals be forced out the hole in the freeze plug the first time the newly assembly area came to operating temperature. More about this when we talk about re-assembling the parts.

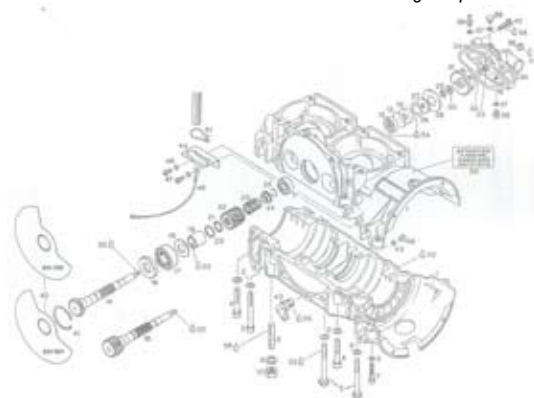

Figure #2 – Shows the order in which the parts located in the 532-582-618 engines. Be sure #16 snap ring is removed before pushing the shaft out from the opposite side of the engine.



Figure #4 – With the shaft removed inspect the area where the two #17 seals have been operating. Replace if worn or grooved.

**Removing the RV Shaft:** Surprisingly enough repairing this area can be accomplished in most cases with the engine in the aircraft. You need to remove the water pump housing and impeller as well as the RV cover behind the carburetors. Remove the snap ring #41 in Figure #2. You may also find a metal "freeze plug" #28 guarding the shaft seals. This will have to be destroyed for removal. At this point you can, only with the right tool, hammer the shaft out from the water pump side. See figure #3. Don't ever think about using a hammer on the naked end of the shaft. Part #876-612 is an inexpensive (for Rotax) tool that threads onto the end of the shaft and allows you to hammer the shaft out. The spring #23 may compress in the process.

Once the shaft is removed you will find a number of parts assembled shish-a-bob style on the shaft. See Figure #4. Compress the spring and remove all parts for inspection. What you need to look for carefully is any cutting or grooving of the shaft in the area where the #12 seals have been running. Replace shaft if wear is present. Removing the #12 seals means destroying them with a seal hook. Take care not to damage the seal passage.

**Reassembling the Shaft:** It is advisable to replace all the seals and to inspect the brass gear thoroughly for wear. You can buy the RV Shaft with all the parts already assembled as shown in Fig. #4 Ask for Part #1351. It comes assembled for the price of the parts only. Install the first #12 seal into passage with the flat side facing out. Rotax makes some very nice and very expensive pushers for installing these seals but generally just the right size deep socket will work fine. Apply lithium or silicone grease liberally to the face of the first seal. This is needed to prevent thermal expansion if an air pocket was left between the seals. Install the second seal with the flat side in. Install the shaft back from the intake side making sure the gears mesh without force. Another inexpensive tool from Rotax # 876-980 can be threaded onto the shaft that protects the seals as the shaft is inserted. See Figure #5. Wipe excess grease from area.



Figure #5 – Rotax makes some inexpensive tools for easy shaft removal and insertion. Both thread onto the end of the shaft.



Figure #6 – Several parts after seal pair are now considered optional. The freeze plug and associated parts help prevent seal walk.

There is a progression of parts that are optional after the seals are installed. A shim, rubber disc, and metal freeze plug can be tapped into cavity for extra support to prevent seal walk. See Figure #6 for parts progression. Reinstall water pump impeller and housing.

**Timing the Rotary Valve Plate:** With the Mag side piston at TDC install the valve plate as shown in Figure #7 with the plate right at or just above the bottom of the Mag side port. Flipping the plate over will give a slightly different positioning.



Figure #7 - With the Mag side piston at TDC install the valve plate as shown with the plate right at or just above the bottom of the Mag side port. Flipping the plate over will give a slightly different positioning.



Figure #8 – The new blue head engines have done away with the rubber seals in favor of a new rotary seal and RV shaft. This combination seems to have no problems reaching the 300 hour TBO mark. Order #8777-258 Seal Tool to install delicate ceramic seal.

**Rotax 582 Model 99:** The new blue head 582 is equipped with a new style ceramic Rotary Seal that takes the place of the old rubber seal pair used on previous engines. This set up uses a completely different RV shaft and is not retrofit able to older engines without extensive machining of the seal passage. See Figure #8.

**Aftermarket Solutions:** Failures of the RV area are common enough for an aftermarket solution to appear. The designer here has come up with an elaborate set up that includes a completely different longer shaft that allows the regular block seals to remain in place and adds an extra pair of seals in a special extension housing. In order for this system to leak you need to loose no less than four seals before a fluid exchange takes place. The other advantage is that to change the outer seals all you need to do is remove the block. The shaft stays put unless it has been grooved. Not a bad fix but with all the new parts you need the conversion is on the expensive side. See Figure #9 for most of the new parts needed for this conversion.



Figure #9 – This aftermarket kit uses a longer shaft plus an extension block to add an extra pair of seals. To change these seals all you have to do is remove the block.



Figure #10 – Havoline Dex-Cool is a patented formula that is silica free. Mix only with mineral free or distilled water to reduce contaminants.

**The Trouble with Silica:** What's silica? Most antifreeze formulas include a small amount of a substance known as "Silica" or SiO<sub>2</sub>. Webster's Dictionary states "Silica is a white or colorless crystalline compound. Occurring as a quartz, sand, flint, agate, and many other minerals and used to make glass or concrete." In short silica is an abrasive compound. Silica will come out of solution during temperature spikes in the cooling system. Silica will then collect on the RV shaft at the seals and acts as an abrasive to allow the contact to cut the shaft. Ever look at the bottom of your radiator cap and see a gel like substance, this is silica. Or if you pour the fluid out and you find a flake like film, that is also silica. In order to get a silica free coolant you need to look for Havoline Dex-Cool® or extended life coolant. This formula is usually an orange color and needs to be mixed 50/50 with mineral free or distilled water as shown in Figure #10. Some Dex-Cool formulas may be already mix 50/50, so check the label carefully. Wouldn't you know it, the black gallon container shown here makes no mention of the word "silica". According to what I understand Dex-Cool® is a patented formula and a closely guard brand name. These products can be found at most automotive parts stores.

**Test have shown that once silica and other contaminants are removed from the coolant the shaft seal cutting problems literally cease to be a factor.** Snowmobiles using the same engines have had little trouble with RV seal because the original equipment comes from the factory with the right coolant. Obviously this is not the case for our industry as most aircraft are supplied in kit form allowing the operator to use most anything for coolant.

**Conclusions:** We posed the question in the beginning "What do I do if water is in the RV Fluid, Can I still fly it?" The answer is a cautious yes. If you are near the 150 or 300 hour inspections, go ahead and change the fluid by pulling the drain plug (#49 in figure #2) and nurse it to your next service interval where you will use the knowledge gained here to service this area properly. Check the fluid often to see the severity of the leakage. Remember that the coolant is under pressure while the RV is just a bath so the RV fluid should be contaminated first. Only in severe cases will the coolant be contaminated as well. If completely neglected the fluids will coagulate or "milk" which will eventually pit the bearings.

For a lot of reasons the fix for this persistent problem was not as obvious as it should have been from the beginning. Silica free coolants are a fairly new product and are fast replacing the more inexpensive products that contain a certain amount of silica. According to factory technicians use of Dex-Cool or any other silica free coolant will allow the RV shaft and seals to last up to and past the recommended 300 hour TBO. A bit on the expensive side, I found it for \$8.00 at the local PEP Boys Store. A gallon of mineral free water was a \$1.50. If you are using tap water or plain antifreeze you might think about investing a few bucks in a coolant change. The savings could be considerable.

**END**

SOURCE: PART 50