



OPERATORS MANUAL

FOR ENGINE TYPES

ROTAX® 447 UL SCDI



ROTAX® 503 UL DCDI



ROTAX® 582 UL DCDI



ROTAX® 447 UL SCDI

ROTAX® 503 UL DCDI

ROTAX® 582 UL DCDI Mod. 90

ROTAX® 582 UL DCDI Mod. 99

 **WARNING**

Before starting the engine, read the Operators Manual, as it contains important safety relevant information. Failure to do so may result in personal injuries including death. Consult the original equipment manufacturer's handbook for additional instructions!

These technical data and the information embodied therein are the property of BRP-Powertrain GmbH & Co KG, Austria, acc, BGBl 1984 no. 448, and shall not, without prior written permission of BRP-Powertrain GmbH & Co KG, be disclosed in whole or in part to third parties. This legend shall be included on any reproduction of these data, in whole or in part. The Manual must remain with the engine/aircraft in case of sale.

Copyright 2010 © - all rights reserved.

ROTAX[®] is a trade mark of BRP-Powertrain GmbH & Co KG. In the following document the short form of BRP-Powertrain GmbH & Co KG = BRP-Powertrain is used.

Other product names in this documentation are used purely for ease of identification and may be trademarks of the respective company or owner.

Approval of translation has been done to best knowledge and judgement - in any case the original text in german language is authoritative.

| | | |
|----|---|-------|
| 1) | Table of contents | 1 - 3 |
| 2) | Index | 2 - 1 |
| 3) | Introduction | 3 - 1 |
| | 3.1) Remarks | 3 - 2 |
| | 3.2) Engine serial number | 3 - 2 |
| 4) | Safety | 4 - 1 |
| | 4.1) Repeating symbols | 4 - 1 |
| | 4.2) Safety information | 4 - 2 |
| | 4.3) Technical documentation | 4 - 6 |
| 5) | Index of pages | 5 - 1 |
| 6) | List of amendments | 6 - 1 |
| 7) | Description of design | 7 - 1 |
| | 7.1) 447 UL SCDI, 503 UL DCDI | 7 - 1 |
| | 7.2) 582 UL DCDI and 582 UL DCDI mod. 99 | 7 - 2 |
| | 7.3) Type description | 7 - 3 |
| | 7.3.1) For 503 UL DCDI, 447 UL SCDI | 7 - 3 |
| | 7.3.2) For ROTAX 582 UL DCDI | 7 - 3 |
| | 7.3.3) For ROTAX 582 UL DCDI mod. 99 | 7 - 3 |
| | 7.4) Engine views | 7 - 4 |
| | 7.4.1) 447 UL DCDI | 7 - 4 |
| | 7.4.2) 503 UL DCDI | 7 - 5 |
| | 7.4.3) 582 UL DCDI and 582 UL DCDI mod. 99 | 7 - 6 |
| 8) | Technical data | 8 - 1 |
| | 8.1) Dimensions | 8 - 1 |
| | 8.2) Weights | 8 - 1 |
| | 8.3) Fuel consumption | 8 - 2 |
| | 8.4) Direction of rotation | 8 - 2 |
| 9) | Description of systems | 9 - 1 |
| | 9.1) Cooling system | 9 - 1 |
| | 9.1.1) Cooling system of ROTAX 447 UL SCDI and of ROTAX 503 UL DCDI | 9 - 1 |
| | 9.1.1.1) Free air cooling | 9 - 1 |
| | 9.1.1.2) Fan cooling | 9 - 1 |
| | 9.1.2) Cooling system of the ROTAX 582 UL DCDI | 9 - 2 |
| | 9.1.3) Cooling system of the ROTAX 582 UL DCDI mod. 99 | 9 - 3 |
| | 9.2) Fuel system | 9 - 4 |
| | 9.3) Lubrication system | 9 - 5 |
| | 9.3.1) Lubrication | 9 - 5 |
| | 9.3.2) Oil injection lubrication of ROTAX 503 UL DCDI, 582 UL DCDI and 582 UL DCDI mod. 99 | 9 - 5 |
| | 9.3.3) Lubrication of the rotary valve drive at 582 UL DCDI and 582 UL DCDI mod. 99 | 9 - 6 |
| | 9.3.4) Gearbox lubrication | 9 - 6 |

d04495

| | |
|--|----------------|
| 9.4) Electric system | 9 - 7 |
| 9.5) Propeller gearbox | 9 - 8 |
| 9.5.1) Type "B" gearbox | 9 - 8 |
| 9.5.2) Type "C" gearbox | 9 - 8 |
| 9.5.3) Type "E" gearbox | 9 - 8 |
| 10) Operating parameters | 10 - 1 |
| 10.1) Performance graphs for stand. conditions (ISA) | 10 - 3 |
| 10.2) Operating media | 10 - 7 |
| 10.2.1) Coolant | 10 - 7 |
| 10.2.2) Fuel | 10 - 8 |
| 10.2.3) Lubricants | 10 - 10 |
| 10.3) Standard operation | 10 - 11 |
| 10.3.1) Before engine start | 10 - 11 |
| 10.3.2) Daily checks | 10 - 12 |
| 10.3.3) Pre-flight checks | 10 - 13 |
| 10.3.4) Engine start | 10 - 14 |
| 10.3.5) Prior to take-off | 10 - 15 |
| 10.3.6) Checking of ignition unit (not possible for 447 UL SCDI) ... | 10 - 15 |
| 10.3.7) Operation in flight | 10 - 15 |
| 10.3.8) Special operating conditions: | 10 - 16 |
| 10.4) Abnormal operation | 10 - 18 |
| 10.4.1) Engine stop - Start during flight | 10 - 18 |
| 10.4.2) Exceeding of max. admissible engine speed | 10 - 18 |
| 10.4.3) Exceeding of max. admissible cyl. head temperature ... | 10 - 18 |
| 10.4.4) Exceeding of max. admissible exhaust gas temperature | 10 - 18 |
| 10.4.5) Too low fuel pressure | 10 - 18 |
| 11) Checks | 11 - 1 |
| 11.1) Engine preservation | 11 - 1 |
| 11.1.1) After each flight | 11 - 1 |
| 11.1.2) At engine stoppage of 1 to 4 weeks | 11 - 1 |
| 11.1.3) At out of service periods or storage of engine for longer than 4 weeks up to 1 year | 11 - 2 |
| 12) Trouble shooting | 12 - 1 |
| 13) ROTAX® authorized Distributors | 13 - 1 |

d04495

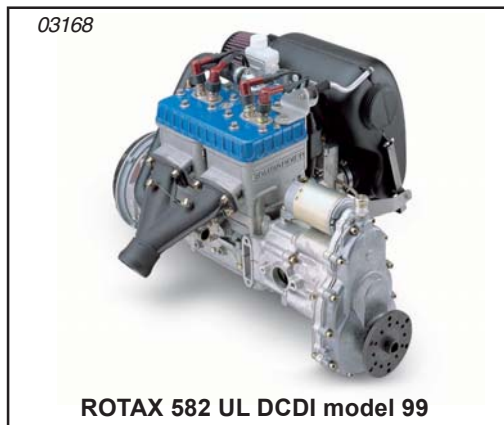
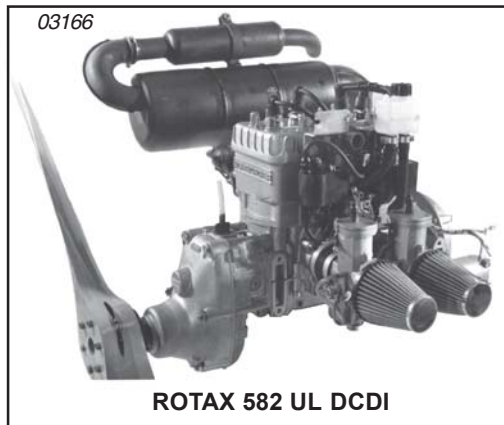

d04495

NOTES

2) Index

A

Abnormal operation 10 - 18

C

Carburetor icing 10 - 16
Checking of ignition 10 - 15
Checks 11 - 1
Coolant 10 - 7
Cooling system 9 - 1, 9 - 2
Cylinder head temperature 10 - 1

D

Daily checks 10 - 11, 10 - 13
Denomination of cylinders 7 - 4
Description of design 7 - 1
Dimensions 8 - 1
Direction of rotation 8 - 2
Dry spark plugs 10 - 14

E

Electric system 9 - 7
Engine lubrication 10 - 10
Engine start 10 - 11, 10 - 14
Engine stop 10 - 18
Engine stoppage of 1 to 4 weeks 11 - 1
Exceeding of max. admissible cyl. head temperature 10 - 18
Exceeding of max. admissible engine speed 10 - 18
Exceeding of max. admissible exhaust gas temperature 10 - 18
Exhaust gas temperatures 10 - 1

F

Fan cooling 9 - 3
Free air cooling 9 - 3
Fuel 10 - 8
Fuel consumption 8 - 2
Fuel system 9 - 4

G

Gearbox lubrication 9 - 6, 10 - 10

H

High air humidity 10 - 16

I

Index 2 - 1
Index of pages 5 - 1
Introduction 3 - 1

L

List of amendments 6 - 1
Lubricants 10 - 10
Lubrication 9 - 5

M

Mixing procedure 10 - 9
Mixture lubrication 10 - 10

N

Noise 10 - 16

O

Oil capacity 10 - 1
Oil injection lubrication 9 - 5, 10 - 10
Operating media 10 - 7
Operating parameters 10 - 1
Operation in flight 10 - 15

P

Performance graphs 10 - 3
Pre-flight checks 10 - 11, 10 - 12
Preservation 11 - 1
Propeller gearbox 9 - 8

R

Rotary valve drive 9 - 6
Rotary valve drive lubrication 10 - 10
ROTAX[®] authorized Distributors 13 - 1

d04496

S

Safety 4 - 1
Safety information 4 - 2
Special operating conditions 10 - 16
Start 10 - 11
Start during flight 10 - 18
Storage of engine for longer than 4 weeks up
to 1 year 11 - 2
Systems 9 - 1

T

Technical data 8 - 1
Technical documentation 4 - 6
Too low fuel pressure 10 - 18
Trouble shooting 12 - 1
Type "B" 9 - 8
Type "C" 9 - 8
Type description 7 - 3
Type "E" 9 - 8

W

Water 10 - 16
Water in fuel 10 - 16
Weights 8 - 1
Wet spark plugs 10 - 14
Winter 10 - 16

3) Introduction

Congratulations on your decision to use a ROTAX aircraft engine.

Before operating the engine, carefully read this Operator's Manual. The Manual provides you with basic information on the safe operation of the engine.

If any passages of the Manual are not understood or in case of any questions, please, contact an authorized Distribution- or Service Center for ROTAX aircraft engines.

We wish you much pleasure and satisfaction flying your aircraft with this ROTAX engine.

3.1) Remarks

This Operator's Manual is provided to familiarize the owner/user of this aircraft engine with basic operating instructions and safety information.

For more detailed maintenance, safety and flight information, consult the documentation provided by the aircraft manufacturer and dealer.

For further information on maintenance and spare parts service, contact the nearest ROTAX distributor (see Chapter 13).

3.2) Engine serial number

On all enquiries or spare parts orders, always indicate the engine serial number, as the manufacturer makes product improvement modifications to the engine. The engine serial number should always be used when ordering parts to ensure correct part selection prior to shipment.

The engine serial number is located on the top of the crankcase, magneto side or ignition cover.

4) Safety

Although the mere reading of these instructions will not eliminate a hazard, the understanding and application of the information herein will promote the proper use of the engine.

The information and components-/system descriptions contained in this Operator's Manual are correct at the time of publication. BRP-Powertrain however, maintains a policy of continuous improvement of its products without imposing upon itself any obligation to install them on its products previously manufactured.

BRP-Powertrain reserves the right at any time to discontinue or change specifications, designs, features, models or equipment without incurring obligation.

The illustrations in this Manual show the typical construction. They may not represent in full detail or the exact shape of the parts which have the same or similar function.

Specifications are given in the SI metric system with the USA equivalent in parenthesis. Where precise accuracy is not required, some conversions are rounded off for easier use.

This document has been translated from the German language and the original German text shall be deemed authoritative.

4.1) Repeating symbols

This Manual uses the following symbols to emphasize particular information:

- ▲ WARNING:** Identifies an instruction which, if not followed, may cause serious injury including the possibility of death.
- CAUTION:** Denotes an instruction which, if not followed, may severely damage the engine or other component.
- ◆ NOTE:** Indicates supplementary information which may be needed to fully complete or understand an instruction.
-  A revision bar outside of page margin indicates a change to text or graphic.

4.2) Safety information

▲ **WARNING:** This engine, by its design, is subject to sudden stoppage. Engine stoppage can result in crash landings, forced landings or no power landings. Such crash landings can lead to serious bodily injury or death

▲ **WARNING:** This is not a certificated aircraft engine. It has not received any safety or durability testing, and conforms to no aircraft standards. It is for use in experimental, uncertificated aircraft and vehicles only in which an engine failure will not compromise safety.

User assumes all risk of use, and acknowledges by his use that he knows this engine is subject to sudden stoppage.

▲ **WARNING:** Never fly the aircraft equipped with this engine at locations, airspeeds, altitudes, or other circumstances from which a successful no-power landing cannot be made, after sudden engine stoppage.

Aircraft equipped with this engine must only fly in DAYLIGHT VFR conditions.

- This engine is not suitable for acrobatics (inverted flight, etc.).
- It should be clearly understood that the choice, selection and use *of this* particular engine on any aircraft is at the sole discretion and responsibility of the aircraft manufacturer, assembler and owner/user.
- Due to the varying designs, equipment and types of aircraft, ROTAX grants no warranty or representation on the suitability of its engine's use on any particular aircraft. Further, BRP-Powertrain grants no warranty or representation of this engine's suitability with any other part, component or system which may be selected by the aircraft manufacturer, assembler or user for aircraft application.
- Whether you are a qualified pilot or a novice, complete knowledge of the aircraft, its controls and operation is mandatory before venturing solo. Flying any type of aircraft involves a certain amount of risk. Be informed and prepared for any situation or hazard associated with flying.

A recognized training program and continued education for piloting an aircraft is absolutely necessary for all aircraft pilots. Make sure you also obtain as much information as possible about your aircraft, its maintenance and operation from your dealer.

- You should be aware that any engine may seize or stall at any time. This could lead to a crash landing and possible severe injury or death. For this reason, we recommend strict compliance with the maintenance and operation and any additional information which may be given to you by your dealer.
- Respect all government or local rules pertaining to flight operation in your flying area. Fly only when and where conditions, topography, and airspeeds are safest.
- Select and use proper aircraft instrumentation. This instrumentation is not included with the BRP-Powertrain engine package. Only approved instrumentation may be installed.
- Before flight, ensure that all engine controls are operative. Make sure all controls can be easily reached in case of an emergency.
- Unless in a run up area, never run the engine with the propeller turning while on the ground. Do not operate engine if bystanders are close.
- In the interest of safety, the aircraft must not be left unattended while the engine is running.

- Keep an engine log and respect engine and aircraft maintenance schedules. Keep the engine in top operating condition at all times. Do not operate any aircraft which is not properly maintained or has engine operating irregularities which have not been corrected.
- Keep an engine log and enter any unusual engine behaviour. Do not fly unless you have corrected a given problem and recorded the correction in the log.
- Since special tools and equipment may be required, engine servicing should only be performed by an authorized ROTAX engine dealer or a qualified trained mechanic approved by the local airworthiness authority.
- To eliminate possible injury or damage, ensure any loose equipment or tools are properly secured before starting the engine.
- Never leave your aircraft or other vehicle unattended while the engine is running. If operated by someone else you could be sued even if the use was unauthorized by you.
- When in storage protect the engine and fuel system from contamination and exposure.
- Certain areas, altitudes and conditions present greater risk than others. The engine may require carburetor recalibration or humidity or dust/sand preventative equipment, or additional maintenance may be required.
Consult your aircraft dealer or manufacturer and obtain the necessary information, especially before flying in new areas.
- Never operate the engine and gearbox without sufficient quantities of lubricating oil.
- Periodically verify level of coolant at 582 UL and 582 UL mod. 99.
- Never exceed maximum rated r.p.m.
Allow the engine to cool at idle for several minutes before turning off the engine.
- Maintain your engine in top condition and assume it's going to quit running at any time. Leave yourself a way out in the event of unexpected failure.
- Never mix fuel in an enclosed area, or where fumes could reach an ignition point.

d04498

- Make sure all engine controls are operative, that you know ON and OFF positions of throttle and ignition, that they are easily accessible, and that you can operate them instinctively without hesitation.
- Never refuel if fuel could be spilled on hot engine components. Use only safety approved fuel containers and never transport fuel in an unsafe manner.
- Check engine suspension frequently as well as the drive components, fuel lines, wiring, and fuel and air filters.
- Check for fuel contamination, air cleaners, etc. Protect engine while not in use from any contamination entering fuel or carburetion system, but be sure to remove storage protection before starting engine.

4.3) Technical documentation

- ◆ NOTE: The information given in the
- Installation Manual
 - Operator's Manual
 - Maintenance Manual
 - Spare parts List
 - Service Informations

are based on data and experience that is considered applicable for professionals under normal conditions.

Any reference to a document refers to the latest edition issued by BRP-Powertrain if not stated otherwise.

- ◆ NOTE: The status of Manuals can be determined by checking the table of amendments of the Manual. The 1st column of this table is the revision status. Compare this number to that listed on the ROTAX WebSite: www.rotax-aircraft-engines.com. Updates and current revisions can be downloaded for free.

The fast technical progress and variations of installation might render present laws and regulations inapplicable or inadequate.

The illustrations in this Manual are mere sketches and show a typical arrangement. They might not represent the actual part in all its details but depict parts of the same or similar function. Therefore deduction of dimensions or other details from illustrations is not permitted.

All necessary documentation is available from the ROTAX Distribution- and Service Centers (see Chapter 13).

- ◆ NOTE: The Illustrations in this Operator's Manual are stored in a graphic data file and are provided with a consecutive irrelevant number.
- This number (e.g. 00277) is of no significance for the content.

d04498

5) Index of pages

09155

| Chapter | Page | Date | Chapter | Page | Date |
|---------|------------|------------|---------|-----------|------------|
| | cover page | | | | |
| 1 | 1 - 2 | 01 09 2010 | 9 | 9 - 1 | 01 09 2010 |
| | 1 - 3 | 01 09 2010 | | 9 - 2 | 01 09 2010 |
| | 1 - 4 | 01 09 2010 | | 9 - 3 | 01 09 2010 |
| 2 | 2 - 1 | 01 09 2010 | | 9 - 4 | 01 09 2010 |
| | 2 - 2 | 01 09 2010 | | 9 - 5 | 01 09 2010 |
| 3 | 3 - 1 | 01 09 2010 | | 9 - 6 | 01 09 2010 |
| | 3 - 2 | 01 09 2010 | | 9 - 7 | 01 09 2010 |
| 4 | 4 - 1 | 01 09 2010 | 10 | 9 - 8 | 01 09 2010 |
| | 4 - 2 | 01 09 2010 | | 10 - 1 | 01 09 2010 |
| | 4 - 3 | 01 09 2010 | | 10 - 2 | 01 09 2010 |
| | 4 - 4 | 01 09 2010 | | 10 - 3 | 01 09 2010 |
| | 4 - 5 | 01 09 2010 | | 10 - 4 | 01 09 2010 |
| | 4 - 6 | 01 09 2010 | | 10 - 5 | 01 09 2010 |
| 5 | 5 - 1 | 01 09 2010 | | 10 - 6 | 01 09 2010 |
| | 5 - 2 | 01 09 2010 | | 10 - 7 | 01 09 2010 |
| 6 | 6 - 1 | 01 09 2010 | | 10 - 8 | 01 09 2010 |
| | 6 - 2 | 01 09 2010 | | 10 - 9 | 01 09 2010 |
| 7 | 7 - 1 | 01 09 2010 | | 10 - 10 | 01 09 2010 |
| | 7 - 2 | 01 09 2010 | | 10 - 11 | 01 09 2010 |
| | 7 - 3 | 01 09 2010 | | 10 - 12 | 01 09 2010 |
| | 7 - 4 | 01 09 2010 | | 10 - 13 | 01 09 2010 |
| | 7 - 5 | 01 09 2010 | | 10 - 14 | 01 09 2010 |
| | 7 - 6 | 01 09 2010 | | 10 - 15 | 01 09 2010 |
| 8 | 8 - 1 | 01 09 2010 | | 10 - 16 | 01 09 2010 |
| | 8 - 2 | 01 09 2010 | | 10 - 17 | 01 09 2010 |
| | | | | 10 - 18 | 01 09 2010 |
| | | | 11 | 11 - 01 | 01 09 2010 |
| | | | | 11 - 02 | 01 09 2010 |
| | | | 12 | 12 - 01 | 01 09 2010 |
| | | | | 12 - 02 | 01 09 2010 |
| | | | 13 | 13 - 01 | 01 09 2010 |
| | | | | 13 - 02 | 01 09 2010 |
| | | | | 13 - 03 | 01 09 2010 |
| | | | | 13 - 04 | 01 09 2010 |
| | | | | rear page | |

d04499

NOTES

6) List of amendments

Approval*

The technical content of this document is approved
under the authority of DOA Nr. EASA.21J.048.

09157

| Currt. no. | Chapter | Pages | Date of modification | Note of approval | Date of approval by authority | Date of insertion | Marks/Signature |
|------------|---------|-------|----------------------|------------------|-------------------------------|-------------------|-----------------|
| 0 | 1÷13 | all | 01 09 2010 | DOA* | | | |

d04888

NOTES

7) Description of design

7.1) 447 UL SCDI, 503 UL DCDI

2 cylinder in line two stroke engine, piston ported, air cooled cylinder heads and cylinders, fan or free air version.

Mixture lubrication and on the 503 oil injection lubrication as an **optional extra**.

Double (503) or single (447) ignition of a breakerless, magneto capacitor-discharge design

◆ **NOTE:** 447 engine is only available with single ignition.

Carburation with one or two piston type carburetors.

One pneumatic fuel pump.

Propeller drive via flange connected gearbox with incorporated shock absorber.

Exhaust system.

Rewind starter.

Intergrated AC generator (12V 170 W) with external rectifier-regulator as **optional extra**.

Air filter.

Intake silencer, **optional extra**.

■ **CAUTION:** At refitting of this intake silencer the carburetor must be recalibrated by an authorized person.

After muffler, **optional extra**.

High Altitude Compensation kit (HAC), **optional extra**.

Electric starter, **optional extra**.

7.2) 582 UL DCDI and 582 UL DCDI mod. 99:

Two stroke engine, 2 cylinder in line with rotary valve inlet.

Liquid cooled cylinder head and cylinders.

Integrated water pump.

Mixture lubrication or oil injection lubrication.

Dual ignition of a breakerless magneto capacitor discharge design.

2 piston type carburetors.

1 pneumatic fuel pump.

Propeller drive via flange connected gearbox with incorporated torsional shock absorber.

Exhaust system: standard version (48 KW) or version of reduced noise emission (40 KW) as **optional extra only at 582 UL DCDI**.

Electric starter or rewind starter.

Integrated AC generator (12 V 170 W) with external rectifier-regulator as **optional extra**.

Air filter.

Intake silencer, **optional extra**.

■ CAUTION: At refitting of this silencer the carburetor has to be newly calibrated by an authorized person.

After muffler, **optional extra**.

High Altitude Compensation kit (HAC), **optional extra**.

Electric starter, **optional extra**.

Radiator (one-piece or two-piece radiator set)

◆ NOTE: 582 UL 40 DCDI and 582 48 DCDI are no longer available.
582 UL DCDI mod. 99 is only available as 48 KW version.

7.3) Type description:

◆ NOTE: The type designation is of the following composition.

7.3.1) For 503 UL DCDI, 447 UL SCDI

ROTAX UL

└──────────┘ └──────────┘

Type
(type)

Zündung
(ignition)

02929

e.g. ROTAX 503 UL DCDI

7.3.2) For ROTAX 582 UL DCDI

ROTAX 582 UL DCDI

└──┘

Leistung
power output

02932

Power output: 40 KW or 48 KW

e.g. ROTAX 582 UL DCDI 48

7.3.3) For ROTAX 582 UL DCDI mod. 99

ROTAX 582 UL DCDI mod. 99

02977

7.4) Engine views:

7.4.1) 447 UL SCDI

PTO view

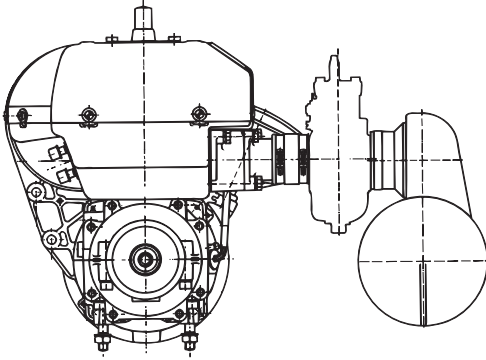

02781

fig. 1

lateral view

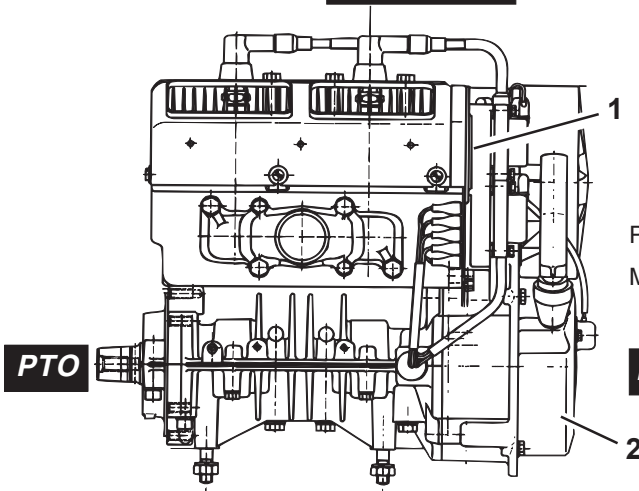

02782

PTO power take off side
MAG magneto side

- (1) engine number
- (2) rewind starter

fig. 2

◆ NOTE: Figure shows fan cooled version with intake silencer.

PTO view

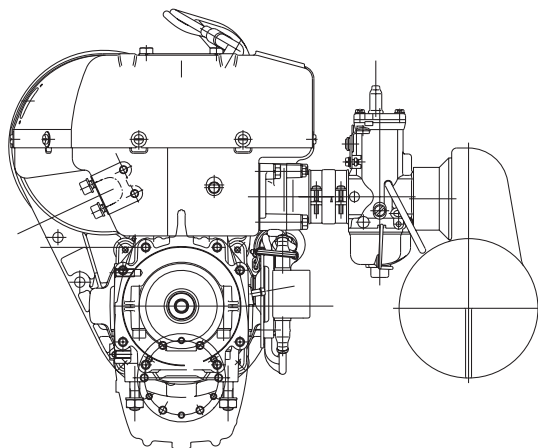

lateral view

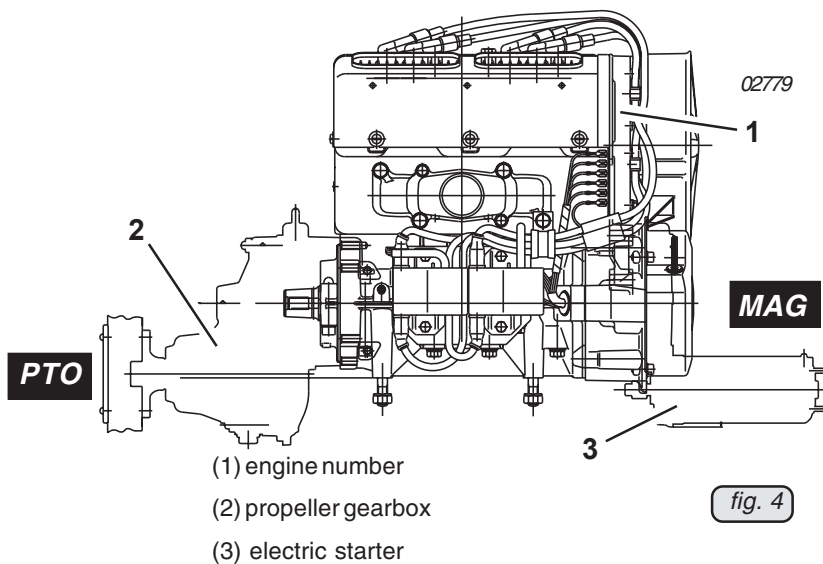

- (1) engine number
- (2) propeller gearbox
- (3) electric starter

◆ NOTE: Figure shows fan cooled version with intake silencer.

PTO view

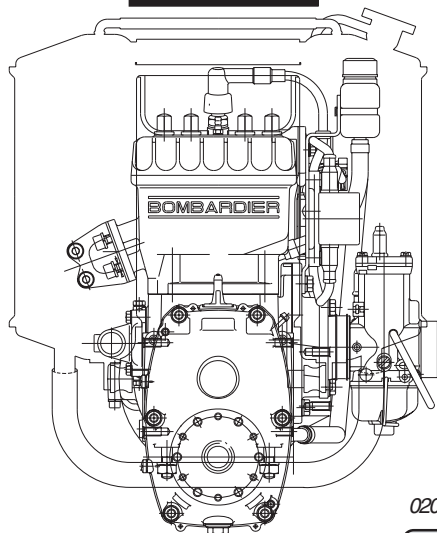

02042

fig. 5

lateral view

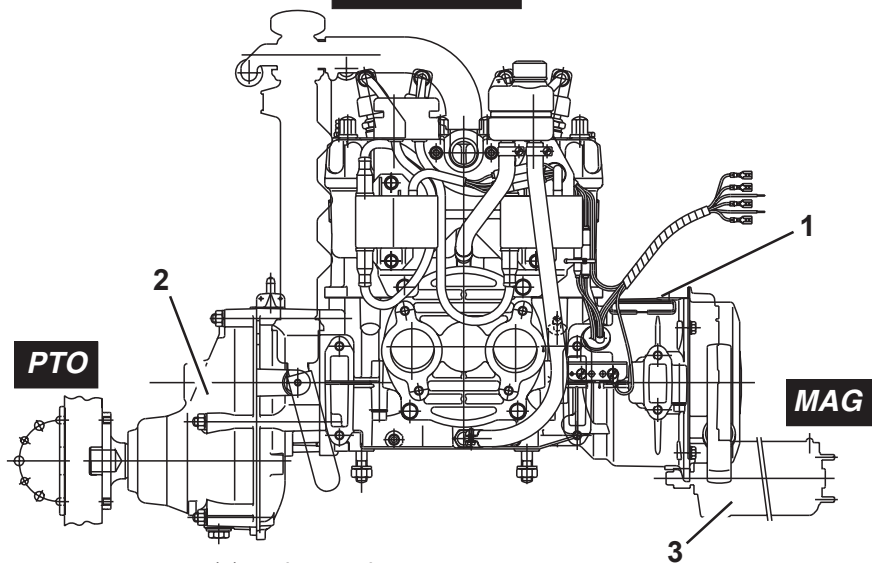

- (1) engine number
- (2) propeller gearbox
- (3) Electric starter

02043

fig. 6

◆ NOTE: Figure shows 582 UL DCDI engine with B-gearbox.

041889

8) Technical data

8.1) Dimensions

| description | 447 UL SCDI | | 503 UL DCDI | | 582 UL DCDI / mod. 99 | |
|--------------------------------|-------------------------------------|-----------|-------------------------------------|-----------|-------------------------------------|-----------|
| bore | 67,5 mm | (2,66 in) | 72 mm | (2,84 in) | 76 mm | (2,99 in) |
| stroke | 61 mm | (2,4 in) | 61 mm | (2,4 in) | 64 mm | (2,52 in) |
| displacement | 436,5 cm ³ (26,64 cu.in) | | 496,7 cm ³ (30,31 cu.in) | | 580,7 cm ³ (35,44 cu.in) | |
| comp. ratio theoretical | 9,6 : 1 | | 10,8 : 1 | | 11,5 : 1 | |
| comp. ratio effective | 6,3 : 1 | | | | 5,75 : 1 | |

02935

8.2) Weights

◆ NOTE: The stated weights are dry weights (without operating fluids)

without: exhaust system, radiator

| Type | 447 UL SCDI | | 503 UL DCDI | | 582 UL DCDI mod. 99 | | 582 UL DCDI | |
|--------|-------------|----|-------------|----|---------------------|------|-------------|------|
| | kg | lb | kg | lb | kg | lb | kg | lb |
| Weight | 26,8 | 59 | 31,4 | 69 | 29,3 | 64,6 | 27,4 | 60,4 |

02936

| | 447 UL SCDI | | 503 UL DCDI | | 582 UL DCDI / mod. 99 | |
|------------------|-------------|------|-------------|------|-----------------------|------|
| | kg | lb | kg | lb | kg | lb |
| exhaust system | 4,9 | 11 | 5,1 | 11,2 | 5,1 | 11,2 |
| 1 carburetor | 0,9 | 2 | 0,9 | 0,9 | 0,9 | 2 |
| "B" gearbox | 4,5 | 9,9 | 4,5 | 9,9 | 4,5 | 9,9 |
| "C" gearbox | 8 | 17,6 | 8 | 17,6 | 8 | 17,6 |
| "E" gearbox | 11,2 | 24,6 | 11,2 | 24,6 | 11,2 | 24,6 |
| Electric starter | 3,5 | 7,7 | 3,5 | 7,7 | 3,5 | 7,7 |

02968

d04890

8.3) Fuel consumption

| | | | |
|------------------------------------|------------------------|------------------------|-------------------------|
| Fuel consumption in l/h (US gal/h) | 447 UL SCDI | 503 UL DCDI | 582 UL DCDI mod. 99 |
| at take-off performance | 20 l/h (5,3 US gal/h) | 25 l/h (6,6 US gal/h) | 26,5 l/h (7 US gal/h) |
| at 75 % continuous performance | 11 l/h (3 US gal/h) | 15 l/h (4 US gal/h) | 20,5 l/h (5,4 US gal/h) |
| specific fuel consumption | 500 g/kWh (0,8 lb/hph) | 550 g/kWh (0,9 lb/hph) | 425 g/ kwh (0,7 lb/hph) |

02969

8.4) Direction of rotation

Direction of rotation on propeller shaft: clockwise, looking at p.t.o. side of engine.

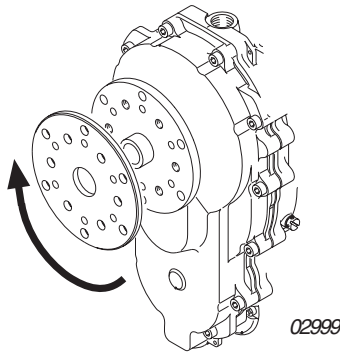

fig. 7

9) Description of systems

9.1) Cooling system

9.1.1) Cooling system of ROTAX 447 UL SCDI and of ROTAX 503 UL DCDI

Two versions of air cooling are available.

9.1.1.1) Free air cooling

Engine cooling by air-stream generated by aircraft speed and propeller.

9.1.1.2) Fan cooling

Cooling in air-stream generated by fan.

The fan is permanently driven from the crankshaft via a V-belt.

9.1.2) Cooling system of the ROTAX 582 UL DCDI

The cooling liquid is supplied by a integrated pump in the engine through the cylinders and the cylinder head to the radiator. The cooling system must be installed such that vapour coming from the cylinders and the cylinder head can escape to top via a hose either into the water tank of the radiator or to an expansion chamber.

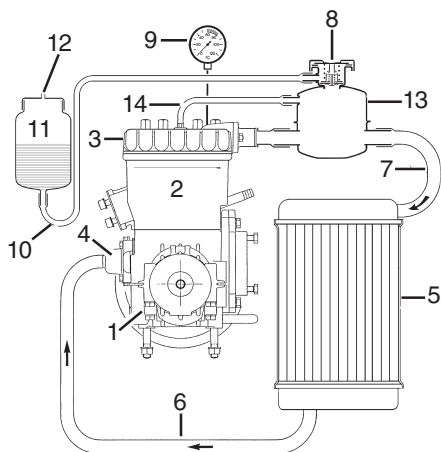

- 1 crankcase
- 2 cylinder
- 3 cylinder head
- 4 water pump
- 5 radiator
- 6 hose from radiator to water pump
- 7 hose from cylinder head to radiator
- 8 radiator screw cap, with excess pressure valve and return valve
- 9 temperature gauge for cooling water
- 10 overflow hose
- 11 overflow bottle
- 12 bottle venting
- 13 expansion tank
- 14 cylinder head venting hose

fig. 8

09177

9.1.3) Cooling system of the ROTAX 582 UL DCDI mod. 99

Engine cooling is performed by liquid cooled cylinder and cylinder head.

The cooling system is in a two circuit arrangement.

The cooling liquid is supplied by a integrated pump in the engine through the cylinders and the cylinder head to the radiator. The cooling system has to be installed such that vapour coming from the cylinders and the cylinder head can escape to top via a hose either into the water tank of the radiator or to an expansion chamber.

The expansion tank is closed by a pressure cap (with excess pressure valve and return valve). At temperature rise of the coolant the excess pressure valve opens and the coolant will flow via a hose at atmospheric pressure to the transparent overflow bottle. When cooling down, the coolant will be sucked back into the cooling circuit.

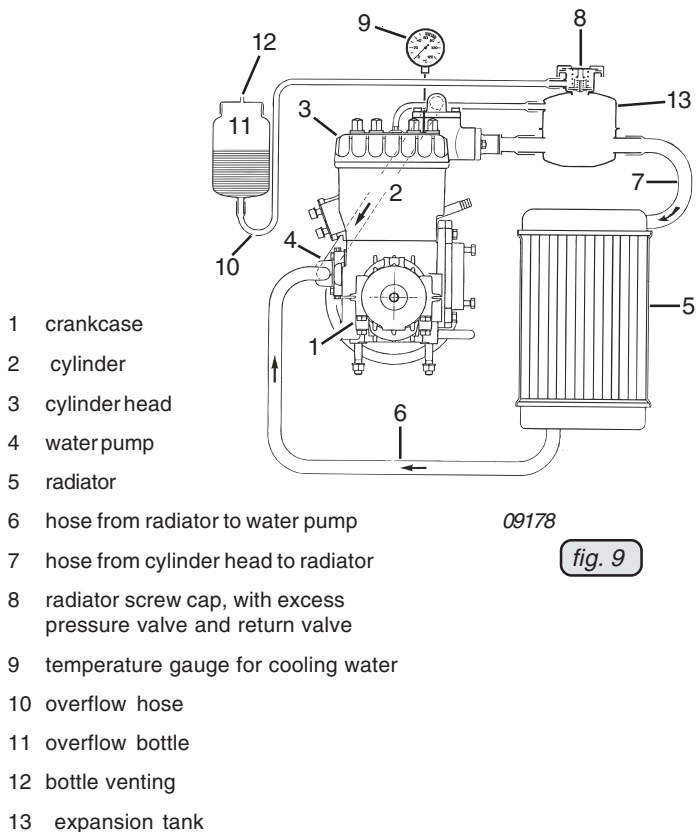

9.2) Fuel system

Generally, the engines are planned to run on a oil-gasoline mixture of 1 : 50. This mixture also supplies proper engine lubrication.

If the engine has been assembled for oil injection lubrication, the engine will be run on pure gasoline.

The integrated oil pump will deliver the exact amount of oil required for engine lubrication.

Make sure that adequate amount of oil is in the oil tank before putting engine into service.

◆ NOTE: For fuel refer to section 10.2.2.

9.3) Lubrication system

9.3.1) Lubrication

Generally the engines are designed to run on a mixture of gasoline and 2 % oil.

For preparation of fuel-oil mixture refer to section 10.2.2.

9.3.2) Oil injection lubrication of ROTAX 503 UL DCDI, 582 UL DCDI and 582 UL DCDI mod. 99

The oil pump (1) driven by the crankshaft (2) via the pump gear (3) (or via cross shaft at 582 UL DCDI and 582 UL DCDI mod.99) feeds the engine with fresh oil. The oil pump is a piston type pump with metering system. Via diffuser jets in the intake cover respectively intake socket each cylinder is supplied with exactly proportioned quantity of Super two-stroke oil. The oil quantity is defined by the engine r.p.m and the oil pump lever position. This lever is actuated via a Bowden cable connected to the throttle cable. The oil comes to the pump from an oil tank by gravity.

▲ **WARNING:** In case of fresh oil lubrication, the carburetors are fed with pure gasoline (no oil/gasoline mixture).

◆ **NOTE:** Figure shows version 503. Oil pump is driven by pump gear.

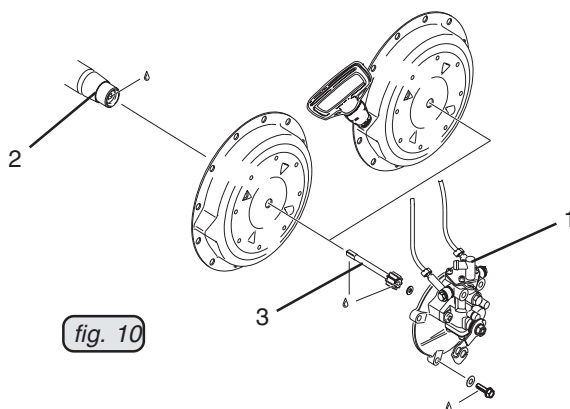

02783

c04891

9.3.3) Lubrication of the rotary valve drive at 582 UL DCDI and 582 UL DCDI mod. 99

A 90° spiral gear situated in the crankcase and running in oil bath drives the rotary valve.

9.3.4) Gearbox lubrication

Gearbox lubrication operates with its own oil filled into gearbox housing.

Never operate engine with a dry gearbox.

◆ NOTE: For lubricants refer to section 10.2.3.

d04891

9.4) Electric system

The engine types 503 UL DCDI, 582 UL DCDI and 582 UL DCDI mod. 99 are equipped with a breakerless dual capacitor discharge ignition unit with integrated generator.

The engine 447 UL SCDI is equipped with a breakerless, single capacitor discharge ignition unit with integrated generator.

The ignition unit is completely free of maintenance and needs no external power supply.

Two charging coils fitted on the generator stator and independent from each other feed one each ignition circuit. The energy supplied is stored in the ignition capacitor. At the moment of ignition the external triggers supply an impulse to the control circuits and the ignition capacitors are discharged via the primary winding of the ignition coil. The secondary winding supplies the high voltage for the ignition spark.

◆ NOTE: The grey cable is planned for a rev-counter signal.

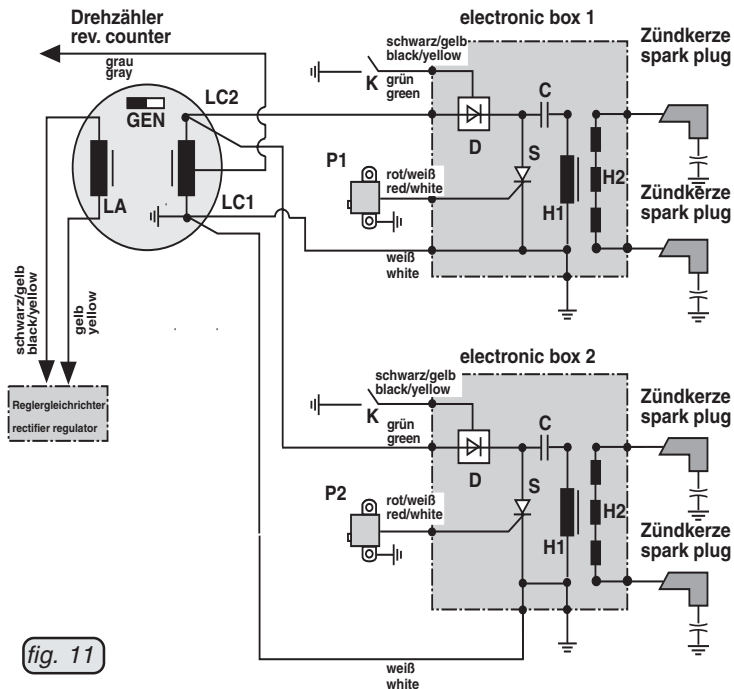

fig. 11

◆ NOTE: The lighting generator can also be incorporated in the gearbox EL or CL as an optional extra.

9.5) Propeller gearbox

There are three different gearboxes available as optional extras:

9.5.1) Type "B" gearbox

available gear ratios

| | |
|------------------------------|----------|
| crankshaft : propeller shaft | 2,00 : 1 |
| | 2,24 : 1 |
| | 2,58 : 1 |

9.5.2) Type "C" gearbox

available gear ratios

| | |
|------------------------------|----------|
| crankshaft : propeller shaft | 2,62 : 1 |
| | 3,00 : 1 |
| | 3,47 : 1 |
| | 4,00 : 1 |

◆ NOTE: This gearbox is not planned for 447 UL SCDI

◆ NOTE: This type of gearbox designated as CL is also available with an incorporated lighting generator.

9.5.3) Type "E" gearbox

available gear ratios

| | |
|------------------------------|----------|
| crankshaft : propeller shaft | 2,62 : 1 |
| | 3,00 : 1 |
| | 3,47 : 1 |
| | 4,00 : 1 |

◆ NOTE: This gearbox is not planned for 447 UL SCDI

◆ NOTE: This type of gearbox designated as EL is also available with an incorporated lighting generator.

c04891

10) Operating parameters

1. Speed:

Take-off speed 6800 RPM max. 5 min
 Take-off speed at 582 UL DCDI 40 6400 RPM max. 5 min
 cruising speed 6500 RPM
 cruising speed at 582 UL DCDI 40 6000 RPM
 Idle speed ca. 2000 RPM

2. Take off Performance (ISA): (International Standard Atmosphere)

| | | | | |
|-------------|-------------|-------------|---------------------|-------|
| 447 UL SCDI | 503 UL DCDI | 582 UL DCDI | 582 UL DCDI mod. 99 | 02846 |
| 29,5 kW | 37 kW | 40 kW | 48 kW | |

3. Oil capacity of oil injection lubrication at 1500 rpm pump speed per outlet

| 503 UL DCDI | | 582 UL DCDI / mod. 99 | | 02970 |
|--------------------|---------|-----------------------|---------|-------|
| cm ³ /h | cu.in/h | cm ³ /h | cu.in/h | |
| max. 192 | 11,7 | max. 135 | 8,2 | |

4. Cylinder head temperature (reading at spark plug seat):

| dimension | 447 UL SCDI | | 503 UL DCDI | | 582 UL DCDI / mod. 99 | |
|---------------------------------|-------------|---------|-------------|-----------|-----------------------|-----------|
| | °C | °F | °C | °F | °C | °F |
| max. | 260 | 500 | 250 | 480 | 150 | 300 |
| normal | 190-230 | 374-446 | 180-220 | 350 - 430 | 110 -130 | 230 - 270 |
| difference between cyl. 1 and 2 | max. 20 | 36 | max. 20 | 34 | max. 10 | 16 |

02971

5. Exhaust gas temperatures:

| dimension | 447 UL SCDI | | 503 UL DCDI | | 582 UL DCDI mod. 99 | |
|---------------------------------|-------------|----------|-------------|----------|---------------------|----------|
| | °C | °F | °C | °F | °C | °F |
| max. | 650 | 1200 | 650 | 1200 | 650 | 1200 |
| normal | 460-580 | 860-1000 | 460-580 | 860-1000 | 500-620 | 930-1150 |
| difference between cyl. 1 and 2 | max. 25 | 43 | max. 25 | 43 | max. 25 | 43 |

09472

004892

- 6. **Engine start, operating temperature:**
 - max. 50 °C (120° F)
 - min. -25 °C (- 13° F)

- 7. **Coolant temperature on ROTAX 582 UL DCDI / mod. 99:**
 - max. 80 °C (175° F)
 - min. 65 °C (150° F)

- 8. **Fuel pressure:**
 - max. 0,4 bar (6 psi)
 - min. 0,2 bar (3 psi)

10.1) Performance graphs for stand. conditions (ISA)

a) 447 UL SCDI

MOTORLEISTUNG / ENGINE PERFORMANCE

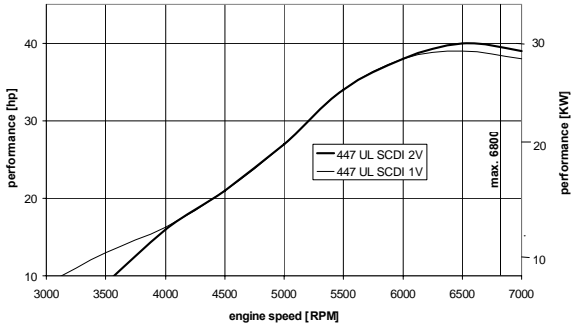

02789

fig. 12

MOTORDREHMOMENT / ENGINE TORQUE

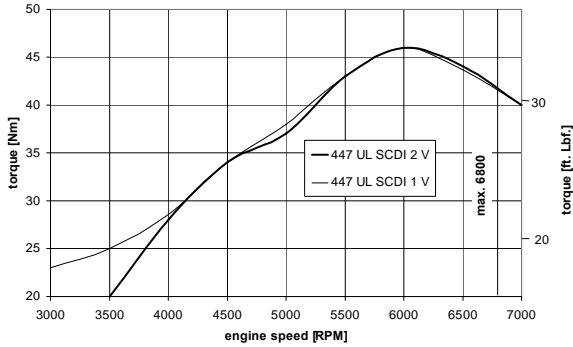

02788

fig. 13

TREIBSTOFFVERBRAUCH / FUEL CONSUMPTION

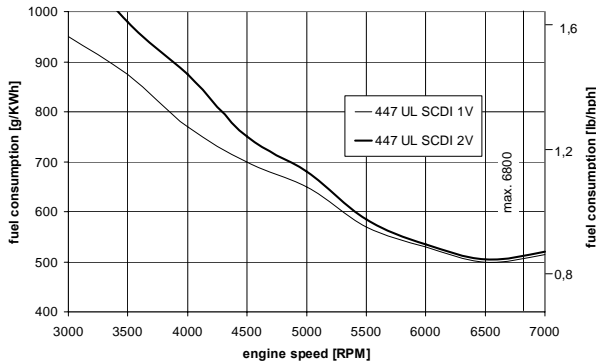

02787

fig. 14

d04892

b) 503 UL DCDI

MOTORLEISTUNG / ENGINE PERFORMANCE

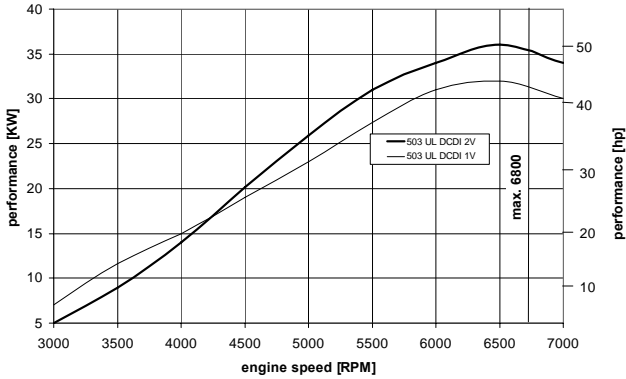

fig. 15

02786

MOTORDREHMOMENT / ENGINE TORQUE

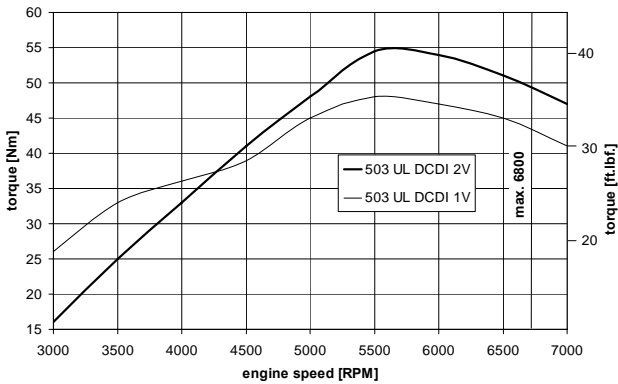

fig. 16

02785

TREIBSTOFFVERBRAUCH / FUEL CONSUMPTION

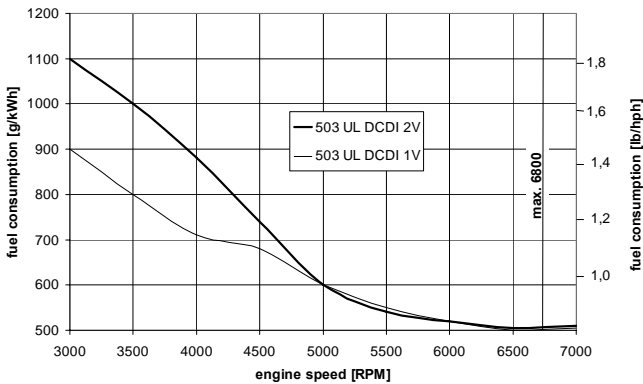

fig. 17

02784

c04892

c) 582 UL DCDI 40

MOTORLEISTUNG / ENGINE PERFORMANCE

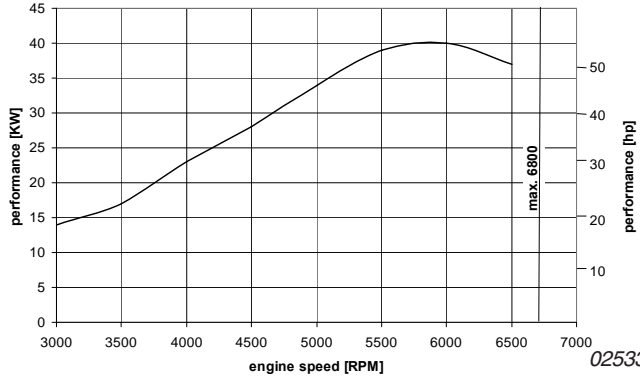

MOTORDREHMOMENT / ENGINE TORQUE

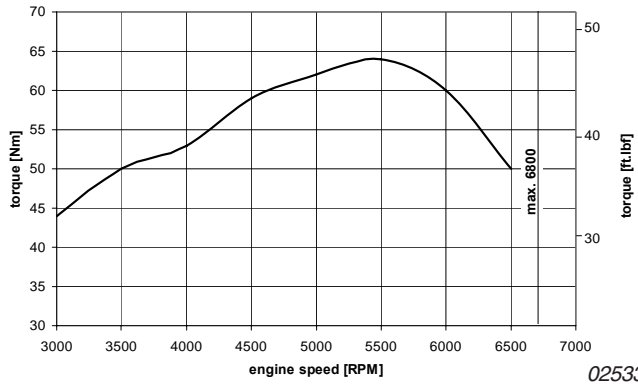

TREIBSTOFFVERBRAUCH / FUEL CONSUMPTION

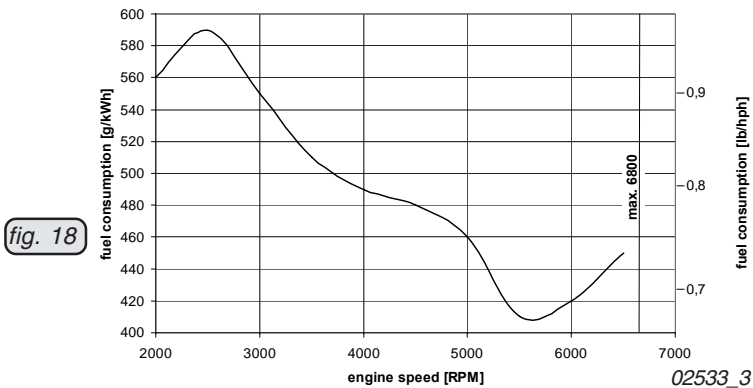

d04892

d) 582 UL DCDI 48 and 582 UL DCDI mod.99

MOTORLEISTUNG / ENGINE PERFORMANCE

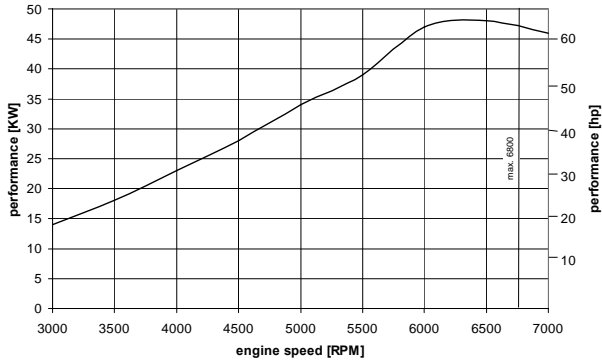

02532_1

MOTORDREHMOMENT / ENGINE TORQUE

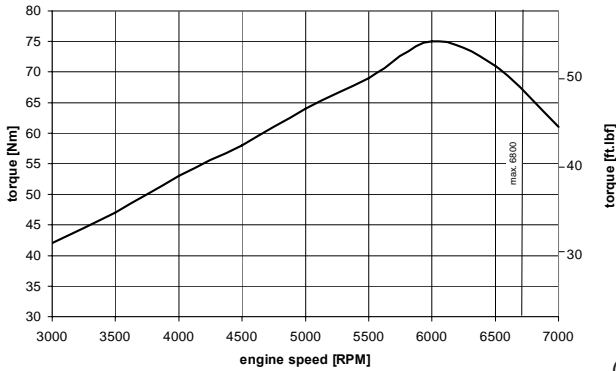

02532_2

TREIBSTOFFVERBRAUCH / FUEL CONSUMPTION

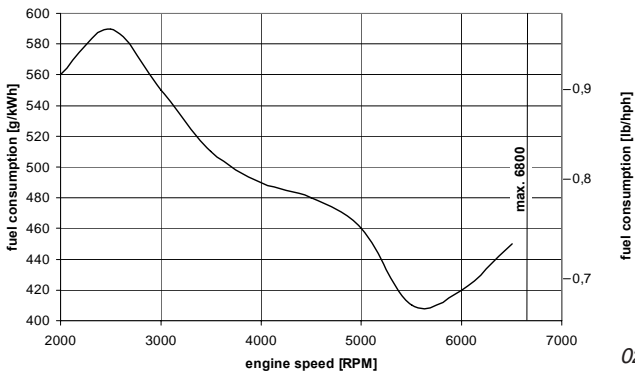

02532_3

fig. 19

d04892

10.2) Operating media

10.2.1) Coolant

Mixing ratio antifreeze / water

50 % antifreeze concentrate with additives against corrosion and 50 % pure water, or use of an equivalent premixed coolant.

■ CAUTION: Take note of the specification from the antifreeze producer.

Satisfactory results were achieved with "BASF Glysantin Anticorrosion". Use this or an equivalent coolant.

◆ NOTE: If problems are encountered with boiling after engine stop increase percentage of antifreeze gradually.

In all cases, antifreeze to water ratios should not exceed the antifreeze manufacturer's recommendations. Exceeding the antifreeze manufacturers recommended ratios can lead to the formation of particulates in the coolant solution or inadequate protection against freezing.

■ CAUTION: Particulate formation may be harmful to cooling system components and may restrict coolant flow to and from overflow bottle.

◆ NOTE: At verification of the coolant level replenish water in expansion tank. The coolant level in the overflow bottle should be between min. and max. mark.

10.2.2) Fuel

The following fuels can be used.

| European standard | American standard | Canadian standard |
|---------------------|-------------------|-------------------|
| min. RON 90 | | min AKI 87 |
| EN 228 Regular | ASTM D 4814 | CAN/CGSB-3,5 |
| EN 228 premium | | Quality 1 |
| EN 228 premium plus | | |
| AVGAS 100 LL | | |

03000

Due to its high lead content AVGAS forms increased deposits in the combustion chamber and lead sediments in the oil system. Therefore use AVGAS only if you encounter problems with vapour lock or if the other fuel types are not available,

or

equivalent fuels according to this Chapter.

- CAUTION: Use only fuel suitable for the relevant climatic conditions.
- ◆ NOTE: Risk of vapour formation in using winter fuel for summer operation.
- CAUTION: If the engine is not equipped with injection lubrication a 2 % Super two stroke oil must be added to the fuel.

d04892

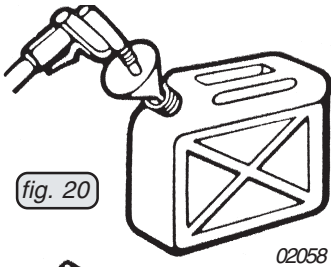

fig. 20

02058

Mixing procedure

STEP no.1: Use a clean approved container of known volume. To help predilute the oil, pour a bit of fuel into the container.

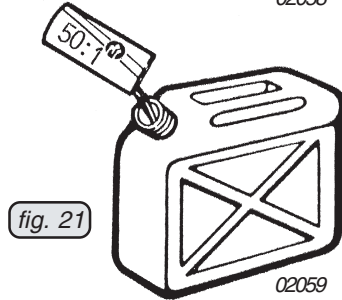

fig. 21

02059

STEP no.2: Fill known amount of oil into container. Oil must be approved for air cooled engines at 50:1 mixing ratio. Agitate slightly to dilute oil with gasoline.

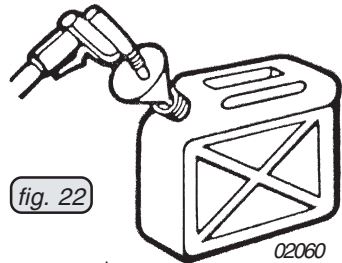

fig. 22

02060

STEP no.3: Add gasoline to obtain desired mixture ratio (use fine mesh screen).

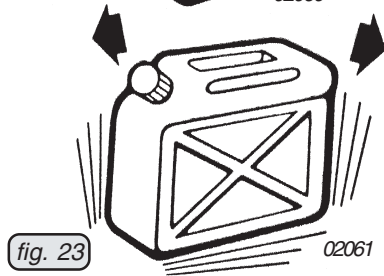

fig. 23

02061

STEP no.4: Replace container cap and shake the container thoroughly. Then using a funnel with a fine mesh screen to prevent the entry of water and foreign particles, transfer mixture from container into the fuel tank.



▲ WARNING:

At refueling use only metal containers and ground the aircraft in accordance with the grounding specifications to avoid electrostatic charging.

10.2.3) Lubricants

a) Engine lubrication

1) **Mixture lubrication:** Super two stroke oil ASTM/CEC standards, API-TC classification (e.g. Castrol TTS) mixing ratio 1 : 50 (2 %).

2) **Oil injection lubrication (optional extra):**

Oil as specified above.

■ **CAUTION:** The pour point of the oil must be at least 10°C below the ambient temperature.

b) Gearbox lubrication

Gear oil API-GL5 or GL6, SAE 140 EP,
or 85 W - 140 EP.

c) Rotary valve drive lubrication

Super two stroke oil (same as used for engine lubrication).

¹⁾ On 503 UL DCDI and 582 UL DCDI and 582 UL DCDI mod. 99.

d04892

10.3) Standard operation

To warrant reliability and efficiency of the engine, meet and carefully observe all the operating and maintenance instructions.

10.3.1) Before engine start

Carefully read and comply with the following guidelines:

- **Daily checks (section 10.3.2)**
- **Pre-flight checks (section 10.3.3)**
- **Start**

The life span of the engine depends to a great extent on compliance with these guidelines.

- ◆ **NOTE:** Prior to engine start verify that installation is complete and make sure that all engine controls are easily accessible and that you can operate them instinctively without hesitation.
- ◆ **NOTE:** Secure the area accordingly.

10.3.2) Daily checks

▲ **WARNING:** Repair as necessary all discrepancies and shortcoming before flight.

- Verify ignition "OFF".
- Drain water from fuel tank sump and/or water trap (if fitted).
- Inspect carburetor rubber socket or flange for cracks and verify secure attachment.
- Inspect carburetor float chamber for water and dirt.
- Verify security and condition of intake silencer and air filter.
- Verify security of radiator mounting. Inspect radiators for damage and leaks.
- Verify coolant level in overflow bottle and security of cap.
- Verify coolant hoses for security, inspect for leaks and chafing.
- Inspect engine for coolant leaks (cylinder head, cylinder base and water pump).
- Verify oil content for rotary valve gear lubrication and security of oil cap.
- Verify oil hoses for security, inspect for leaks and chafing (rotary valve gear lubrication system and oil injection system).
- Verify ignition coils / electronic boxes for secure mounting. Check ignition leads and all electrical wiring for secure connections and chafing.
- Verify electric starter for secure mounting, inspect cover for cracks.
- Verify engine to airframe mounting for security and inspect cracks.
- Verify fuel pump mounting for security. Inspect all fuel hose connections, filters, primer bulbs and taps for security, leakage, chafing and kinks.
- Verify fuel pump impulse hose for secure connections, inspect for chafing and kinks.
- Verify safety wiring of gearbox drain and level plugs.
- Inspect rubber coupling for damage and aging (C type gearbox only).
- Rotate engine by hand and listen for unusual noises (first double verify that ignition is OFF).
- Check propeller shaft bearing for clearance by rocking propeller.
- Inspect throttle choke and oil pump lever cables for damage (end fittings, outer casing and kinks).

d04892

10.3.3) Pre-flight checks

- ▲ **WARNING:** Repair as necessary all discrepancies and shortcoming before flight.
- Verify ignition "OFF".
- Check fuel content.
- Inspect for coolant leaks.
- Verify oil tank content (oil injection engines).
- Verify spark plug connectors for security.
- Inspect engine and gearbox for oil leaks.
- Inspect engine and gearbox for loose or missing nuts, bolts and screws. Verify security of gearbox to engine mounting.
- Inspect propeller for splits and chips. If any damage, repair and/or rebalance before use.
- Verify security of propeller mounting.
- Check throttle, oil injection pump and choke actuation for free and full movement.
- Verify that cooling fan turns when engine is rotated (air cooled engines).
- Inspect exhaust for cracks, security of mounting, springs and hooks for breakage and wear, verify safety wiring of springs.
- Start engine after assuring that area is clear of bystanders.
- Single ignition engines - check operation of ignition switch (flick ignition off and on again at idling).
- Dual ignition engines - check operation of both ignition circuits.
- Check operation of all engine instruments during warm up.
- If possible, visually check engine and exhaust for excessive vibration during warm up (indicates propeller out of balance).
- Verify that engine reaches full power rpm during take off roll.

10.3.4) Engine start

▲ **WARNING!** Do not take the engine into operation if any person is near the aircraft.

On cold engine, apply choke fully. Ensure idle position of throttle valves as opening throttle will greatly reduce choke effect resulting in hard starting.

Make sure ignition switch is on and that you can shut it off instantly if necessary. Pull starter until firmly engaged and then pull smartly through.

■ **CAUTION:** At employment of an electric starter, activate starter for max. 10 sec. only (without interruption), followed by a cooling period of 2 min.

Above procedure should be repeated until engine begins to "fire". As soon as engine starts, shift the throttle slowly to low speed and remove choke as soon as possible. Prolonged use of choke can cause engine to flood.

If the engine fails to start or operates only on one cylinder, check whether the ignition wiring is correctly connected to the spark plug connectors, check spark plugs and check the ignition is in ON position.

■ **CAUTION:** Ensure grounding switch is in correct position and wired correctly.

d04892

10.3.5) Prior to take-off

Warming up period:

Start warming up period at 2000 engine r.p.m. for approx. 2 minutes, continue at 2500 r.p.m. until operating temperatures are reached.

- Verify that temperatures and pressures are in operational range prior to take off.

Throttle response:

- Short full throttle ground test (consult Aircraft Operator's Manual since engine speed depends on the propeller used).

- **CAUTION:** After a full-load ground test, allow a short cooling run to prevent vapour formation in the cylinder head.

10.3.6) Checking of ignition unit (not possible for 447 UL SCDI)

Before every flight or operation, the function of the two ignition systems must be checked. For checking the ignition unit the engine must be operated at 3000 to 3500 1/min and alternately ignition system 1 and 2 must be switched off. The RPM-drop must not exceed max. 300 1/min.

10.3.7) Operation in flight

It is recommended to use full throttle during take-off and climb, if not specified otherwise, slight throttle reduction may create a leaner mixture and should be avoided. Select a cruising speed where the engine is running smooth.

Do not exceed maximum engine rpm.

During cruise and descending it is very important not to create a lean condition with high rpm and low throttle opening. The less fresh charge the engine gets, the more hot residual gas remains in the cylinder. This raises the temperatures to a critical level. For this reason, you may also experience higher exhaust gas and cylinder head temperatures at reduced throttle openings.

Minimum engine idle speed is 2000 engine r.p.m. Higher idle r.p.m. setting will reduce enrichment action of starting circuit in carburetor (choke) making cold starting difficult.

Prior to shutdown, engine should be run until latent heat build-up from previous high power settings has been dissipated (approx. 3000 r.p.m. or at nearest smooth running r.p.m. for a minimum of two minutes followed by a short period of idle - 2000 r.p.m.).

Do not idle for prolonged periods as normal rich condition present at this power setting can cause unnecessary carbon deposits and spark plug fouling. Additional shock loads present at idle cause gear box, propeller, and/or drive train to operate in conditions which should be avoided whenever possible.

10.3.8) Special operating conditions:

Water:

There are dangers to your engine that you may not experience on land. Some of these dangers are water ingestion on take-off or landing due to spray and splash, corrosion, electrolysis, and, worst of all, unintentional submersion.

Bearings, crankshaft etc., are highly susceptible to corrosion. Synthetic oils, although good lubricants, often attract moisture rather than repel it.

A well designed and well maintained air intake system (e.g. ROTAX intake silencer with K & N oil impregnated air filter) will help to prevent water ingestion.

d04892

Noise:

The air intake silencer kit will provide significant engine noise reduction. Further noise reduction may be obtained by the use of an after-muffler kit. Be aware that modifications will require a different carburetor setting.

Enquire at your dealer for more information, and consult ROTAX.

Winter:

Winter can create additional problems such as carburetor icing, frozen fuel lines, higher air densities etc., which may affect carburetor calibration and require longer warm-up periods.

Carburetor icing:

Distinguish between two kinds of carburetor icing,

Icing due to water in fuel:

Water in fuel will accumulate at the lower parts of the fuel system and leads to freezing of fuel lines, filters or jets.

Icing because of high air humidity:

Carb icing due to humidity may occur on the fuel exit and on the carb piston and lead to performance loss by changes to the mixture.

Effective remedy is possible only by preheating intake air.

Remedies:

- Fuelling without traces of water (use shammy as filter).
- Generously sized water trap.
- Fuel line routing inclined.
- Prevent condensation of humidity, i.e. avoid temperature differences between aircraft and fuel.

■ **CAUTION:** Fuels containing alcohol always carry a small amount of water in solution. In case of temperature changes or increase of alcohol content, water or a mixture of alcohol and water may settle and could cause troubles.

10.4) Abnormal operation

▲ **WARNING:** At unusual engine behaviour conduct checks as per Chapter 10.4.1) through 10.4.5) below, and according to the relevant section in the Maintenance Manual.

◆ **NOTE:** Further checks - see Maintenance Manual.

10.4.1) Engine stop - Start during flight

Starting procedure same as on ground, however, on a warm engine without choke.

10.4.2) Exceeding of max. admissible engine speed

Reduce engine speed. Any exceeding of the max. admissible engine speed must be entered by the pilot into the logbook, stating duration and extent of overspeed.

10.4.3) Exceeding of max. admissible cyl. head temperature

▲ **WARNING:** Reduce engine power setting to the minimum necessary and carry out precautionary landing.

Any exceeding of the max. admissible cylinder head temperature must be entered by the pilot into the logbook, stating duration and extent of excess-temperature condition.

10.4.4) Exceeding of max. admissible exhaust gas temperature

▲ **WARNING:** Reduce engine power setting to the minimum necessary and carry out precautionary landing.

Any exceeding of the max. admissible exhaust gas temperature must be entered by the pilot into the logbook, stating duration and extent of excess-temperature condition.

10.4.5) Too low fuel pressure

▲ **WARNING:** Reduce engine power setting to the minimum necessary and carry out precautionary landing.

▲ **WARNING:** Repair as necessary all discrepancies and shortcomings before next flight.

d04892

11) Checks

All checks to be carried out as specified in the current Maintenance Manual (last revision).

▲ **WARNING:** **Only qualified staff (experienced two stroke mechanics) trained on this particular engine, are allowed to carry out maintenance and repair work.**

■ **CAUTION:** Carry out all directives of Service Informations, according to their **priority.**

11.1) Engine preservation

If the engine is not going to be used for a extended period of time, certain measures must be taken to protect engine against heat, direct sun light, corrosion and formation of residues.

In particular the water bonded by the alcohol in the fuel causes increased corrosion problems at engine stops or storage. Especially affected are essential engine components such as crankshaft bearings and conrod bearings as well as crank pins and piston pins.

11.1.1) After each flight

- Activate choke for a moment before stopping engine
- Close all engine openings like exhaust pipe, venting tube and air filter to prevent entry of contamination and humidity.

11.1.2) At engine stoppage of 1 to 4 weeks

- proceed with preservation prior to engine stop or on the engine at operating temperature.
- let the engine run at increased idle speed
- shut engine down and secure against inadvertent engine start
- remove air filters and inject approx. 3 ccm of preservation oil or equivalent oil into the air intake of each carburetor.
- restart engine and run at increased idle speed for 10 - 15 seconds
- shut engine down and secure against inadvertent engine start
- close all engine openings such as exhaust pipe, venting tube and air filter to prevent entry of contamination and humidity.

11.1.3) At out of service periods or storage of engine for longer than 4 weeks up to 1 year

- proceed with preservation prior to engine stop and on the engine at operating temperature
- let the engine run at increased idle speed
- remove air filters and inject approx. 6 cm³ of preservation oil or equivalent oil into the air intake of each carburetor
- stop engine
- remove spark plugs and inject approx. 6 ccm preservation oil or equivalent oil into each cylinder and slowly turn crankshaft 2 to 3 turns by hand to lubricate top end parts. Refit spark plugs.
- drain gasoline from float chambers, fuel tank and fuel lines.
- drain coolant on liquid cooled engines, to prevent any damage by freezing
- ▲ **WARNING:** Generally comply with standard rules for handling of chemicals. Dispose of chemicals as per local environmental regulations.
- Lubricate all carburetor linkages.
- Close all openings of the engine like exhaust end pipe, venting tube and air intake to prevent entry of dirt and humidity.
- spray all external steel parts with engine oil.

12) Trouble shooting

▲ WARNING: Only qualified staff (experienced two stroke mechanics) trained on this particular engine, are allowed to carry out maintenance and repair work.

If the following hints regarding remedy do not solve the problem, contact an authorized workshop. The engine must not be operated until the problem is rectified.

Your ROTAX engine requires basicly two essentials to run. Spark and correct fuel/air mixture. The majority of problems quite often are a simple lack of one or the other.

Follow an organized method of troubleshooting. This will facilitate the identification of discrepancies or shortcomings.

Fuel: start by checking the supply (tank), fittings (loose?), filter (plugged?), float chamber (fouled?).

Spark: try new plugs.

Problems of a more complex nature are best left to a ROTAX engine technician: see your service center.

Engine keeps running with ignition off

POSSIBLE CAUSE:

a - overheating of engine

REMEDY:

let engine cool down at idling at approx. 2000 engine r.p.m.

Knocking under load

POSSIBLE CAUSE:

a - Octane rating of fuel too low

b - fuel starvation, lean mixture

REMEDY:

use fuel with higher octane rating.

check fuel supply.

13) Authorized Distributors for ROTAX[®] Aircraft Engines
www.rotax-aircraft-engines.com

Issue 01 09 2010

1) EUROPE

CROATIA / former YUGOSLAVIA
(except SLOVENIA):

► **SHAFT D.O.O.**

B.L. Mandica 161 a
HR-54000 OSIJEK
Tel.: +385 (0) 31 / 280-046
Fax: +385 (0) 31 / 281 602
E-mail: shaft@os.tel.hr
Website: www.shaft.hr
Contact person: Ivan Vdovjak

CZECHIA / SLOVAKIA:

► **TEVESO S.R.O.**

Skroupova 441
CS-50002 HRADECKRALOVE
Tel.: +42 049 / 5217 127
Fax: +42 049 / 5217 226
E-mail: motory@teveso.cz
Website: www.teveso.cz
Contact person: Jiri Samal

FRANCE / ALGERIA / BELGIUM /
LUXEMBURG / MAROCCO /
MONACO / TUNISIA:

► **MOTEUR AERO DISTRIBUTION**

11 Blvd Albert 1
98000 MONACO
Tel.: +377 (0) 93 30 17 40
Fax: +377 (0) 93 30 17 60
E-mail: mad@libello.com
Website: www.moteuraerodistribution.com
Contact person: Philippe Thys

GERMANY / AUSTRIA / BULGARIA /
HUNGARY / LIECHTENSTEIN /
ROMANIA / SWITZERLAND /
THE NETHERLANDS:

► **FRANZ AIRCRAFT ENGINES**
VERTRIEB GMBH

Am Weidengrund 1a, 83135 Schechen,
GERMANY
Tel.: +49 (0) 8039 / 90350
Fax: +49 (0) 8039 / 9035-35
E-mail: info@franz-aircraft.de
Website: www.franz-aircraft.de
Contact person: Eduard Franz

GREAT BRITAIN / IRELAND /
ICELAND:

► **SKYDRIVE LTD.**

Burnside, Deppers Bridge
SOUTHAM, WARWICKSHIRE CV472SU
Tel.: +44 (0) 1926 / 612 188
Fax: +44 (0) 1926 / 613 781
E-mail: sales@skydrive.co.uk
Website: www.skydrive.co.uk
Contact person: Nigel Beale

ITALY / CYPRUS / GREECE / MALTA /
LIBYA:

► **LUCIANO SORLINI S.P.A.**

Piazza Roma, 1
Carzago di Calvagese Riviera (Brescia), Italy
Tel.: +39 030 / 601 033
Fax: +39 030 / 601 463
E-mail: avio@sorlini.com
Website: www.sorlini.com
Contact person: Alberto Comincioli

POLAND:

► **FASTON LTD.**

ul. Zwirki i Wigury 47
PL-21-040 SWIDNIK
Tel.: +48 (0) 81 / 751-2882
Fax: +48 (0) 81 / 751-5740
E-mail: faston@go2.pl
Contact person: Mariusz Oltarzewski

SLOVENIA:

► **PIPISTREL D.O.O. AJDOVSCINA**

Goriska Cesta 50A
5270 AJDOVSCINA
Tel. +386 (0) 5 / 3663 873
Fax: +386 (0) 5 / 3661 263
E-mail: info@pipistrel.si
Website: www.pipistrel.si
Contact person: Leon Brecejl

SPAIN / PORTUGAL:

► **AVIASPORT S.A.**

Almazara 11
E-28760 TRES CANTOS (MADRID)
Tel.: +34 (0) 91 / 803 77 11
Fax: +34 (0) 91 / 803 55 22
E-mail: aviasport@aviasport.com
Website: www.aviasport.com
Contact person: Roberto Jimenez

SWEDEN / FINLAND / NORWAY /
ESTONIA / LATVIA / LITHUANIA /
DENMARK

► **LYCON ENGINEERING AB**

Härkeberga, SE-74596 ENKÖPING
Tel.: +46 (0) 171 / 414039
E-mail: info@lycon.se
Website: www.aeronord.eu

TURKEY:

► **AIR CONSULT**

Belediye Yeri Mah., 368. Sokak,
Vilko Sitesi No. 8,
01360 Adana, TURKEY
Tel.: +90 (0)322 248 0746
Fax: +90 (0)322 248 6927
E-Mail: info@airconsult.com.tr
Contact person: Peter Johannes Girmann

d04895

2) A M E R I C A

CANADA:

► **ROTEC RESEARCH CANADA, LTD.**

6235 Okanagan Landing Rd.
VERNON, B.C., V1H 1M5, Canada
Tel.: +1 250 / 260-6299
Fax: +1 250 / 260-6269
E-mail: inquiries@rotec.com
Website: www.rotec.com

NORTH / MIDDLE / SOUTH AMERICA:

► **KODIAK RESEARCH LTD.**

P.O. Box N 658
Bay & Deveaux Street
NASSAU, BAHAMAS
Tel.: +1 242 / 356 5377
Fax: +1 242 356 2409
E-mail: custsupport@kodiakbs.com
Website: www.kodiakbs.com

3) AUSTRALIA / NEW ZEALAND / PAPUA NEW GUINEA

► **BERT FLOOD IMPORTS PTY. LTD.**

P.O. Box 61, 16-17 Chris Drive
LILYDALE, VICTORIA 3140
Tel.: +61 (0) 3 / 9735 5655
Fax: +61 (0) 3 / 9735 5699
E-mail: wai@bertfloodimports.com.au
Website: www.bertfloodimports.com.au
Contact person: Mark Lester

4) AFRICA

EGYPT:

► **AL MOALLA**

P.O. Box 7787, ABU DHABI
Tel.: +971 (0) 2 / 444 7378
Fax: +971 (0) 2 / 444 6896
E-mail: almoalla@emirates.net.ae
Contact person: Hussain Al Moalla

ANGOLA / BOTSWANA / LESOTHO/ MADAGASCAR / MALAWI / MOZAMBIQUE/ NAMIBIA / SOUTH AFRICA / SWAZILAND/ ZAMBIA / ZIMBABWE:

► **AVIATION ENGINES**

ANDACCESSORIES (PTY) LTD

P.O. Box 15749, Lambton 1414, South Africa
Tel.: +27 (0) 11 / 824 3368
Fax: +27 (0) 11 / 824 3339
E-mail: niren@cometaviationsupplies.co.za
Website: www.aviation-engines.co.za
Contact person: Niren Chotoki

GHANA / BENIN / BURKINA FASO / CAMEROON / CENTRAL AFRICAN REPUBLIC / CONGO / GABON / GUINEA / IVORY COAST / MALI / MAURITANIA / NIGER / NIGERIA / SENEGAL / TOGO:

► **WAASPS LTD.**

PMB KA49, Kotoka International Airport,
Accra, Ghana
Tel.: +233 (0) 28 5075254
Fax: +233 (0) 217 717 92
E-mail: info@waasps.com
Website: www.waasps.com
Contact person: Jonathan Porter

5) A S I A

CHINA / HONG KONG / MACAO:

► **PEIPOINT INDUSTRIES LTD.**

Rm. 1302, Westlands Centre,
20 Westlands Road,
Quarry Bay, HONG KONG
Tel.: +852 (0) 2885 / 9525
Fax: +852 (0) 2886 / 3241
E-mail: admin@peiport.com.hk
Website: www.peiport.com
Contact person: Larry Yeung

CIS:

► **AVIAGAMMA JSCo.**

P.O. Box 51, 125 057 MOSCOW
Tel.: +7 499 / 158 31 23
Fax: +7 499 / 158 62 22
E-mail: aviagamma@mtu-net.ru
Website: www.aviagamma.ru
Contact person: Vladimir Andriytschuk

INDIA:

► **GREAVES COTTON LTD.**

Express Building Annex
9-10, Bahadur Shah Zafar Marg
NEW DELHI - 110002
Tel.: +91 (0) 11 / 23311501,
Fax: +91 (0) 11 / 23702129
E-mail: anilkumar@greavesmail.com
Website: www.greavescotton.com/aeroengines.htm
Contact person: Cdr. Anil Kumar

INDONESIA / MALAYSIA / PHILIPPINES / SINGAPORE / THAILAND / TAIWAN:

► **BERT FLOOD IMPORTS PTY. LTD.**

P.O. Box 61, 16-17 Chris Drive
LILYDALE, VICTORIA 3140
Tel.: +61 (0) 3 / 9735 5655
Fax: +61 (0) 3 / 9735 5699
E-mail: wai@bertfloodimports.com.au
Website: www.bertfloodimports.com.au
Contact person: Mark Lester

IRAN:

► **ASEMAN PISHRANEH CO.**

Register Code: 149432
13 Km of Babaee Exp. Way, Cross Telo Road,
Sepehr Aviation Group, Tehran, Iran
Tel.: +98 (0) 21 77105107
Fax: +98 (0) 21 77000030
E-mail: asmpish@asmpish.com
Contact person: Ali Habibi Najafi

ISRAEL:

► **CONDOR-AVIATION INDUSTRIES LTD.**

P.O. Box 1903, 14 Topaz st.
Cesaria 38900
Tel.: +972 (0) 4 / 6265080
Fax: +972 (0) 4 / 62650 95
E-mail: condor@netvision.net.il
Contact person: David Wiernik

JAPAN :

► **JUA, LTD.**

1793 Fukazawa, Gotemba City
SHIZUOKAPREF 412
Tel.: +81 (0) 550 / 83 8860
Fax: +81 (0) 550 / 83 8224
E-mail: jua@shizuokanet.ne.jp
Contact person: Yoshihiko Tajika, President

KOREA:

► **KOREA BUSINESS AIR SERVICE CO. LTD.**

672-4 KBAS Bldg. Deungchon-dong,
Kangseo-ku, Seoul, South Korea
Tel.: +82 (0) 2 / 3664 - 6644
Fax: +82 (0) 2 / 2658 - 6562
E-mail: sd.lim@kbas.com
Contact person: Su Dong Lim

UNITED ARAB. EMIRATES:

► **AL MOALLA**

P.O. Box 7787
ABU DHABI
Tel.: +971 (0) 2 / 444 7378
Fax: +971 (0) 2 / 444 6896
E-mail: almoalla@emirates.net.ae
Contact person: Hussain Al Moalla

NOTES



Motornummer / Engine serial no.

Flugzeugtype / Type of aircraft

Flugzeugkennzeichen / Aircraft registration no.

ROTAX[®] Vertriebspartner

ROTAX[®] authorized distributor



CALIFORNIA POWER SYSTEMS

EXPERTS IN LIGHTSPORT AVIATION

www.cps-parts.com

800-247-9653

www.rotax-aircraft-engines.com