

# BEARINGS

## HEIM ROD ENDS MALE THREADED M AND HM SERIES

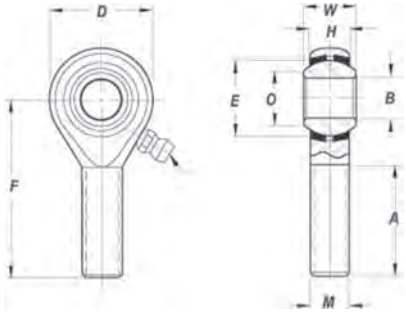

Rod Ends male threaded (HM M Series)

- Outer Member: Aircraft Quality Carbon Steel, Magnetic particle inspected, with protective coating for corrosion resistance.
- Ball: 52100 Alloy Steel, heat treated, chrome plated.
- Inserts: Brass, 16 size has one piece carbon steel race.

Heim "M" and "MD" series bearings are now manufactured in magnafluxed version only. As old stock is depleted, magnafluxed equivalents will be furnished as substitutes at current (higher) prices unless otherwise requested on the order.

"L" in rod end number designates left hand thread. In this series, the "D" in rod end number (MD35 14) denotes drilled hole in the shank. Add suffix "G" to indicate lubricator is required. Example: HM-SG. Add suffix "FG" to indicate flush type lubricator is required. Example: M34-14FG. Lubricator (G) (FG) available with minimum qty. required. Please Call for Pricing.

Rod End No.	Equiv. Spherco No.	DIMENSIONS											Max Static Radial Load in Pounds Approx.	Approx. Weight in Pounds	Price Each	
		Bore	ball Width	Housing Width	Ball Flat Diam.	Head Diam.	Length to center of ball	Overall Length	Other Dimensions							
		B +.0015 -.0005	W +.000 -.005	H +.005 -.005	O	D +.010 -.010	F +.010 -.010	G +.010 -.010	A Min	N Drill Diam.	Ball Diam.	M Class 3A				
M34-14M	NONE	.1900	.437	.328	.273	.750	1.560	1.935	1.000			33/64	1/4"-28	1,695	.05	\$24.50
MD35-14M	NONE	.1900	.437	.328	.273	.875	1.375	1.812	.750	#33	33/64	5/16"-24		2,184	.07	\$51.75
MDL35-14M												UNF				---
MD36-14M	NONE	.1900	.437	.328	.273	.750	1.375	1.750	.750	#33	33/64	3/8"-24		2,848	.07	\$56.85
MDL36-14M												UNF				\$41.25
MD36-16M	NONE	.1900	.500	.375	.321	.812	1.812	2.219	1.062	#29	19/32	3/8"-24		2,769	.08	\$74.90
MDL36-16												UNF				---
M44-14	NONE	.2500	.437	.304	.354	.812	1.562	1.968	1.000		9/16	1/4"-28		1,695	.06	\$66.85
ML44-14												UNF				---
MD46-15	NONE	.2500	.484	.335	.395	.875	2.312	2.750	1.500	#29	5/8	3/8"-24		3,151	.10	\$54.90
MDL46-16												UNF				---
HM-2M	NONE	.1250	.250	.187	.187	.469	.937	1.172	.500		5/16	6-32		452	.02	\$54.95
HM-2AM	NONE	.1562	.281	.219	.249	.562	1.125	1.406	.625		3/8	8-32		666	.02	---
HML-2AM												UNC				---
HM-3M	TRE-3	.1900	.312	.250	.306	.625	1.250	1.563	.750		7/16	10-32		910	.03	\$29.80
HML-3M	TREL-3											UNF				\$210.95
HM-4M	TRE-4	.2500	.375	.281	.355	.750	1.562	1.937	1.000		33/64	1/4"-28		1,695	.05	\$35.90
HML-4M	TREL-4											UNF				\$29.50
HM-5M	TRE-5	.3125	.437	.344	.447	.875	1.875	2.312	1.250	#33	5/8	5/16"-24		2,205	.08	\$42.95
HM-6M	TRE-6	.3750	.500	.406	.517	1.000	1.938	2.438	1.250	#21	23/32	3/8"-24		3,172	.11	\$35.75
HML-6M	TREL-6											UNF				\$41.85
HM-7M	TRE-7	.4375	.562	.437	.586	1.125	2.125	2.688	1.375	#21	13/16	7/16"-20		4,633	.16	---
HML-7M	TREL-7											UNF				---
HM-8M	TRE-8	.5000	.625	.500	.698	1.312	2.438	3.094	1.500	#3	15/16	1/2"-20		5,876	.24	\$99.65
HML-8M	TREL-8											UNF				\$209.95

UNF= Universal Fine, UN=Universal Coarse



## TRIANGLE MFG. BEARINGS

Manufactured by Triangle Mfg. Co., these bearings are spherical on the outside and are contained in a flanged, stamped metal cage, so they provide sliding, rotating, and pivoting motion. The bearings are available in nylon, bronze, or iron as shown in the table below. The FMN10 is used in the wing roots and on the torque tubes inside the fuselage of the Cozy Mark IV.

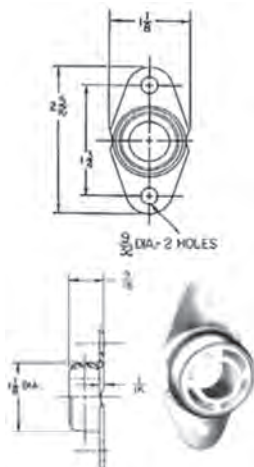

Part No.	I.D.	Bearing Material	Price Each	Part No.	I.D.	Bearing Material	Price Each
FMN4	1/4"	Nylon	\$1.60	FM1508P	1/2"	Iron	\$1.44
FMN5	5/16"	Nylon	\$1.85	FM1408P	1/2"	Bronze	\$3.35
FMN6	3/8"	Nylon	\$1.38	FMN10	5/8"	Nylon	\$2.41
FM1406P	3/8"	Bronze	\$5.25	FM1510P	5/8"	Iron	\$2.45
FMN7	7/16"	Nylon	\$1.61	FM1410P	5/8"	Bronze	\$4.05
FMN8	1/2"	Nylon	\$3.65	FMN12	3/4"	Nylon	\$0.85
				FM1512P	3/4"	Iron	\$1.10