

BING CARBURETORS



COMPLETE CARBURETORS – TYPE 54

To Order, Specify:

1. Model indicated by engine number 277, 377, 447, 503, or 532.
 2. With intake silencer or Without intake silencer.
 3. Single Carb or Dual Carb.
 4. Hand Choke or Remote Choke.
- Model # 54/36/2040**
P/N 07-00303\$475.00

TYPE 54 REBUILD KIT

- #17 Top O Ring #7 Air Screw O Ring
#29 Bowl Gasket #26 Float Needle
#25 Hinge Pin #10 Sieve Sleeve (Screen)
#21 Cable Grommet P/N 07-00304\$54.75

TYPE 54 FIX-IT KIT

- #12 New Spring Cup #56 Jet Needle O Ring
#11 Clip P/N 07-00305\$19.50



COMPLETE CARBURETORS – TYPE 84

To Order, Specify:

1. Model indicated by engine number 277, 377, 447, 503, or 532.
 2. With intake silencer or Without intake silencer.
 3. Single Carb or Dual Carb.
 4. Hand Choke or Remote Choke.
- Model # 84/32/3437** P/N 07-00306.....\$473.00

TYPE 84 REBUILD KIT

- #17 Top O Ring #7 Air Screw O Ring
#29 Bowl Gasket #26 Float Needle
#25 Hinge Pin #10 Sieve Sleeve (Screen)
#21 Cable Grommet P/N 07-00307\$54.75

ROTAX FLOAT CHAMBER 261-010

This Float Chamber replaces a single float bowl. For dual carb applications, order two.
P/N 261-010\$163.75

BING CARBURETOR ACCESSORIES

- Bing Remote Choke Kit (w/8' cable) ... P/N 07-00308.....\$78.75
Bing Remote Choke Kit (w/o cable) ... P/N 07-00309.....\$52.75
Bing Aircraft Parts manual P/N 07-00310.....\$16.60

BING JUNCTION BLOCKS



Bing junction block for dual Carb linkage on any Rotax engine. Three gang outlet can be used dual Carbs or with three way oil injection and dual Carbs.

- Converts a single throttle line into as many as three lines.
3" Junction Block P/N 15-05033\$13.85
4" Junction Block P/N 15-05450\$26.75

CARBURETOR SYNCHRONIZATION

CARB MATE - Quick & easy synchronizing by direct comparison of a set of carbs / Fuel Injector throttle bodies. Range adjustable from 2 to 0,05cmHg per LED. Hook up 2 or 5 cylinder with the optional adapter kit.
CarbMate P/N 07-19346\$144.90
With Rotax 912/914 Accessory Kit.
P/N 07-01891\$187.75



4-CHANNEL ADAPTER KIT

Converts the SynchroMate or CarbMate into a 4 carb/throttle valve synchronizer. This easy-to-mount & easy-to-use kit allows connection of SynchroMate's or CarbMate 2 channels (tubes) to 4 carbs / throttle valves at once.
PN 07-01267\$62.95



Accessories	Part No.	Price
4-Channel adapter kit TS-220	07-01267	\$62.95
Rotax adapter w/ 2X6 ft hose TS-400	07-01889	\$61.80
ROTAX ACCESSORY KIT TS-400 KIT	07-01890	\$96.80
Rotax black nylon storage case TS-222	07-01893	\$41.95
Rotax rubber black holster TS-223	07-01894	\$9.95
Rotax replacement 6 ft rubber hose	07-01895	\$17.50

ROTAX THROTTLE SPRING

Alternate throttle return spring for Rotax 912/914 series engines ... P/N 08-06858\$3.75



REPLACEMENT PARTS – TYPE 54

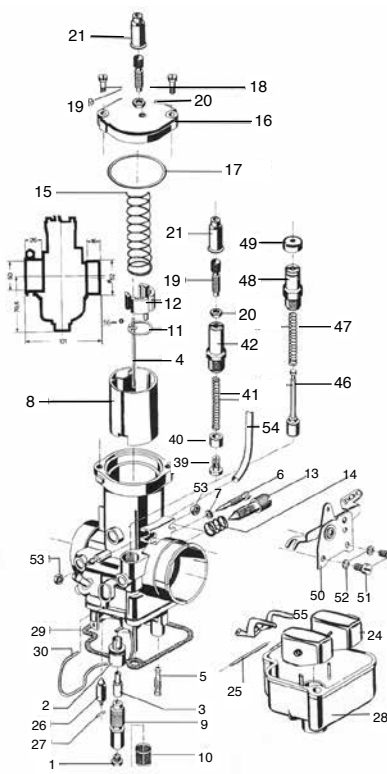

No.	Part No.	Description	Price
1	268-978-998	Main Jet	\$13.50
2	251-554	Atomizer	\$34.50
3	963-691-699	Needle Jet	\$20.50
4	963-711-719	Jet Needle	\$18.75
5	963-140-147	Idler Jet	\$36.50
6	963-155	Air Screw	\$15.50
7	831-710	O Ring	\$4.60
8	963-679	Piston	\$118.75
9	963-700	Mixing Tube	\$24.60
10	261-625	Sieve Sleeve	\$12.50
11	963-500	Clip	\$8.50
12	827-347	New Style Spring Cup	\$11.50
13	963-160	Mix Screw	--
14	938-640	Spring	\$3.65
15	938-655	Slide Spring	\$7.50
16	963-720	Cover Plate	\$36.50
17	831-450	O Ring	--
18	241-430	Screw	\$1.85
19	241-440	Adjuster	\$5.60
20	942-541	Nut	--
21	260-370	Grommet	\$3.45
24	861-181	Indep. Float	\$45.85
26	261-705	Float Needle	\$45.85
27	261-710	Clip	--
28	261-010	Bowl Kit (bowl, 24-27, 55) *Float Needle Valve not incl.	\$163.75
29	830-720	Gasket	\$12.50
30	963-180	Bowl Clip	\$11.50
39	963-740	Piston	\$13.50
40	268-850	Sleeve	\$5.35
41	661-050	Spring	\$2.44
42	963-750	Housing	\$18.50
46	268-847	Piston	\$30.99
47	239-730	Spring	--
48	261-770	Housing	\$15.50
49	260-490	Rubber Cap	\$6.75
50	261-755	Choke Lever	\$33.50
51	240-791	Screw(51) &	--
52	945-750	Washer(52)	--
53	261-200	Nut	\$1.68
54	256-035	Vent Tube	\$14.50
55	861-190	Float Arm	--
56	831-715	Jet Needle O Ring	\$2.06

REPLACEMENT PARTS – TYPE 84

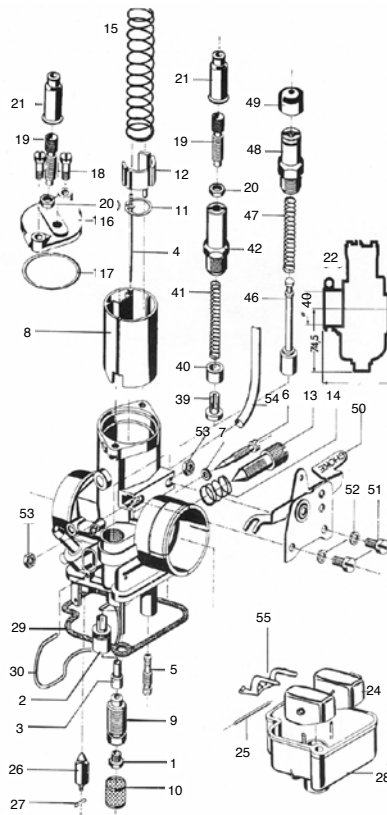

No.	Part No.	Description	Price
1	268-980	Main Jet 135	\$13.50
2	261-692	Atomizer	\$32.50
3	261-606	Needle Jet 262	\$18.50
4	261-643	Jet Needle 8H1	\$24.50
5	963-140	Idler Jet 50	\$36.50
6	963-155	Air Screw	\$15.50
7	831-710	O Ring	\$4.60
8	261-635	Piston	\$75.75
9	963-130	Jet Stock	\$24.95
10	261-625	Screen	\$12.50
11	261-650	Holding Plate	\$9.70
12	227-635	Spring Cup	--
13	963-160	Mix Screw	\$15.50
14	938-640	Spring	\$3.65
15	239-700	Slide Spring	--
16	261-660	Cover	\$28.50
17	261-670	O Ring	\$14.95
18	241-430	Screw	\$1.85
19	241-440	Adjust. Screw	\$5.60
20	942-541	Nut	--
21	260-370	Grommet	\$3.45
26	261-705	Float Needle	\$45.85
27	261-710	Clip	--
28	963-170	Bowl	\$50.95
29	830-720	Gasket	\$12.50
30	963-180	Bowl Clip	\$11.50
39	963-740	Piston	\$13.50
40	268-850	Sleeve	\$5.35
41	661-050	Spring	\$2.44
42	963-750	Housing	\$18.50
46	268-847	Piston	\$30.99
47	239-730	Spring	--
48	261-770	Housing	\$15.50
49	260-490	Rubber Cap	\$6.75
50	261-750	Lever	\$24.85
51	240-791	Screw(51) &	--
52	945-750	Washer(52)	--
53	261-200	Nut	\$1.68
54	256-033	Vent Tube	\$14.50