

# TAILWHEELS

## MAULE MODEL SFSA SOLID TAILWHEELS

The SFSA tailwheel assembly is of the same type construction as the SFS-P8A unit except for the tire, which is a 6.50 x 2.50 soft rubber solid tire. Spring connector kit not furnished with this model. FAA-approved. Wt. 6 lbs.

- SFSA-1-4, for 1-1/4" Spring .....P/N 06-16710
- SFSA-1-2, for 1-1/2" Spring .....P/N 06-16720
- Replacement Tire & Bearings .....P/N TW-23A

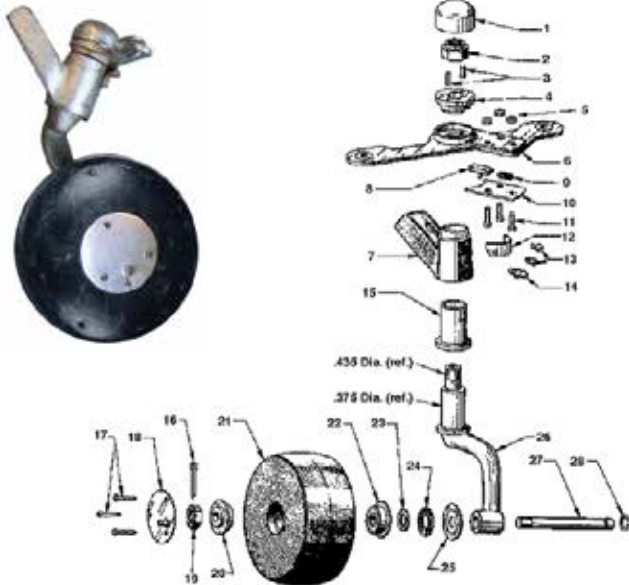

## MAULE MODEL SFS-P8A PNEUMATIC TAILWHEELS

An inexpensive 8" pneumatic tailwheel assembly which is steerable and full swiveling, with new improved single arm shimmy-free fork. All working parts heat treated. FAA approved. Wt. 7 lbs.

- Maule Tailwheel #SFS-P8A-1-4\* .....P/N 06-16730
- Maule Tailwheel #SFS-P8A-1-2\*\* .....P/N 06-16740
- Specialty Tire 2.80/2.50-4 4 Ply .....P/N 06-08000
- Specialty Tube 280 X 250 X 4 .....P/N 06-08101

\* - For 1-1/4" Leafspring      \*\* - For 1-1/2" Leafspring

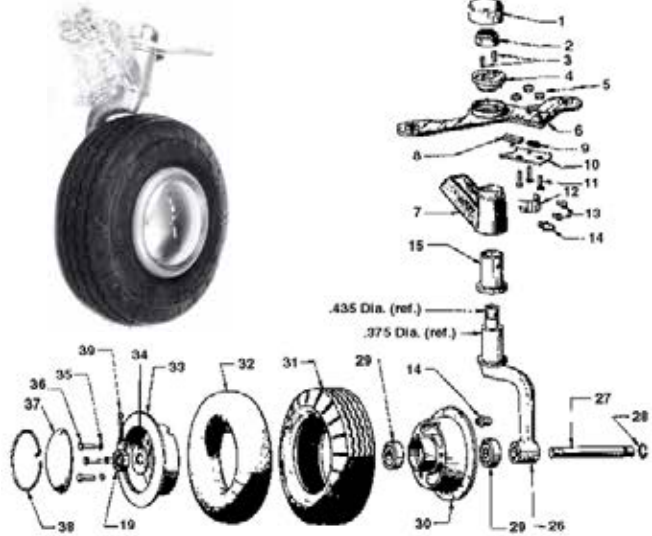

## MAULE P8B TUNDRA TAILWHEEL

A new tailwheel with 8" pneumatic tire designed and engineered to meet the toughest conditions on all types of airports and landing fields.

- SFS-P8B-1-4 ..... For 1-1/4" Leaf Spring Width .....P/N 06-16750
- SFS-P8B-1-2 ..... For 1-1/2" Leaf Spring Width .....P/N 06-16760
- SFS-P8B-3-4 ..... For 1-3/4" Leaf Spring Width .....P/N 06-16770

## MAULE TAILWHEEL PARTS LIST

#	Description	Old Style (Pre 1976) has 3/4" Fork Shaft & New Style (Post 1976) has 7/8" Fork Shaft	Old Style SFS-P8 Pneumatic or SFS Solid Rubber	New Style SFS-P8A Pneumatic and SFSA Solid Rubber	Qty. Req.	Price Each
		Part Number	Part Number	Part Number		
1	Cover Cap	TW-18 (1-1/4")	TW-63A (1-3/8")		1	---
2	Nut	AN364-720A or AN365-720	AN364-720A or AN365-720		1	---
3	Lock Ring Pin	TW-17	TW-60AB		1/2	---
4	Lock Ring	TW-16	TW-57		1	---
5	Nut	AN364-440A	AN364-440A		3	---
6	Steering Arm Assembly*	TW-15 (TW-13 & TW-16 are included in this Assembly)		TW-15A	1	---
7	Bracket Assembly, 1-1/4"	06-16101	06-16201		1	---
7	Bracket Assembly, 1-1/2"	06-16102	06-16202		1	---
8	Lock Pin	TW-13	TW-13		1	---
9	Steering Arm Spring	TW-14	TW-14		1	---
10	Lock Cover Plate	TW-12	TW-12		1	---
11	Screw	MS35206-217	MS35206-217		3	---
12	Cam	TW-10	TW-10		1	---
13	Screw	AN501-A10-4	AN501-A10-4		2	---
		AN520-10-4	AN520-10-4			
14	Zerk Fitting	TW-7-A14	TW-7-A14		1	-----
15	Oilite Bearing	TW-7 (3/4" I.D.)	TW-59A (7/8" I.D.)		1	---
Items 16 through 25 are for the solid rubber tire assembly only.						
16	Cotter Pin	AN380-3-3	AN380-3-3		1	---
17	Screw	TW-A18	TW-A18		3	---
18	Hub Cap	TW-27	TW-27		1	---
19	Axle Nut	AN320-8	AN320-8		1	---
20	Bearing	TW-3	TW-3/A15		1	---
21	Tire—solid, no bearings	TW-23	TW-23		1	---
21	Tire—solid, with bearings	TW-23A	TW-23A		1	---

#	Description	Old Style (Pre 1976) has 3/4" Fork Shaft & New Style (Post 1976) has 7/8" Fork Shaft	Old Style SFS-P8 Pneumatic or SFS Solid Rubber	New Style SFS-P8A Pneumatic and SFSA Solid Rubber	Qty. Req.	Price Each
		Part Number	Part Number	Part Number		
22	Bearing (with washer)	TW-A15	TW-A15		1	---
23	Washer	TW-28	TW-28		1	---
24	Felt Seal	TW-26	TW-26		1	---
25	Retainer Washer Fork (with axle)	TW-64	TW-64		1	---
27	Axle	TW-5	TW-5		1	---
28	Axle Sircilip Ring	TW-6	TW-6		1	---
29	Bearing	TW-A7	TW-A7		2	---
30	Inboard Wheelhalf, with bearings	TW-30	TW-30		1	---
31	Tire, 8-inch				1	-----
32	Tube				1	-----
33	Outboard Wheelhalf	TW-31	TW-31		1	---
34	Washer	TW-A6	TW-A6		1	---
35	Lock Washer	AN935-516	AN935-516		3	---
36	Bolt	TW-A12	TW-A12		3	-----
37	Hub Cap	TW-32	TW-32		1	---
38	Hub Cap Sircilip Ring	TW-33	TW-33		1	---
39	Cotter Pin	AN380-3-3	AN380-3-3		1	---
Items 40 through 44 are used on the "Old" style & pneumatic tailwheel that have a shimmy dampener.						
40	Adjusting Screw	TW-40			1	-----
41	Dampener Spring	TW-41			1	-----
42	Friction Block	TW-42			1	-----
43	Hex Housing	TW-43			1	-----
44	Bracket Assembly, 1-1/4 inch drilled	TW-44-1-4			1	-----
	Bracket Assembly, 1-1/2 inch drilled	TW-44-1-21				-----

## MAULE ARM ASSEMBLIES

Fig. No.	Description	Style	Qty Req.	Part No.	Price
26	Arm Assembly .375 Dia. (Pneumatic)	Old	1	TW-58A	---
26	Arm Assembly without Axle .435 Dia. (Solid Rubber)	New	1	TW-61A	---
26	Arm Assembly with Axle .435 Dia. (Solid Rubber)	New	1	TW-61A	---
26	Arm Assembly .375 Dia. (Pneumatic)	New	1	TW-58A-1	---
26	Arm Assembly .375 Dia. (Solid Rubber)	Old	1	TW-21-1	---

Prices Subject to Change without Notice - Valid as of June 1, 2024. Please view our website for current prices.