

UMA 1-1/4" ENGINE INSTRUMENTS



Monitor your engine's vitals with a full line of space saving 1-1/4" engine instruments with 240 degree analog sweep. These instruments allow you the opportunity to utilize panel space without compromising readability. No longer do you have to decipher cluster gauges or push buttons for readings or try to concentrate on flashing numbers. These premiere UMA instrument are electronic and can be powered from 14 or 28 volts. Signals are acquired from remote mounted sensors, processed and displayed on analog dials with easy to read markings. Each gauge uses rugged aircore meter movement for vibration resistance and repeatability. Each gauge can be placed in a 1-1/4" diameter hole and mounted behind the panel with (4) 6-32 screws. They can be cluster mounted as close as 1 1/2" centers. **Senders are sold separately.**

UMA Technical Support: 800-842-5578.

STREAMLINE • STACKABLE • EASY TO READ • RUGGED DESIGN

CYLINDER HEAD TEMP. (CHT)

Description	Part No.	Price
CHT Gauge 100-300°F	10-00035	---
CHT Gauge 100-600°F	10-00036	---
CHT Thermocouple 14mm Plug (Rotax)	10-00962	---
CHT Thermocouple 18mm Plug (Lyc.)	10-00963	---
CHT Thermocouple 3/8-24 Bayonet (Lyc.)	10-00795	---

OIL PRESSURE

Description	Part No.	Price
Oil Pressure Gauge 0-80 PSI	10-00037	---
Oil Pressure Gauge 0-130 PSI	10-00038	---
Oil Pressure Gauge 0-130 PSI Rotax 912/914	10-05509	---

FUEL QUANTITY

Description	Part No.	Price
Fuel Qty. Ind. (Float 240-30)	10-00039	---
Fuel Qty. Ind. (Cap. 5v)	10-00040	---
Sender (Capacitance 0-5V)	10-00797	---

AMMETER

Description	Part No.	Price
Ammeter ±30 Shunt incl.	10-00041	---
Ammeter ±100 Shunt incl.	10-00043	---
Ammeter +60	10-00581	---
Ammeter +80	10-00582	---

WATER PRESSURE

Description	Part No.	Price
Water Press. Gauge 0-15 PSI	10-00044	---
Water Press. Gauge 0-30 PSI	10-00045	---

WATER TEMPERATURE

Description	Part No.	Price
Water Temp. Gauge 100-300°F	10-02457	---

CARB. TEMPERATURE

Description	Part No.	Price
Carb. Temp -60-120°F	10-05769	---

OUTSIDE AIR TEMPERATURE

Description	Part No.	Price
OAT (-25) -40°C	10-02385	---
OAT (-10) -110°F	10-02386	---

TACHOMETERS

Description	Part No.	Price
0-7000 RPM for Rotax 447/503/582	10-05507	---
0-7000 RPM for Rotax 912/914	10-05506	---

EXHAUST GAS TEMPERATURE (EGT)

Description	Part No.	Price
EGT Gauge 700-1700°F	10-00046	---
EGT Gauge 100-900°C	10-05696	---
EGT Gauge 1000-2000°F	10-05697	---
EGT Thermocouple Clamp style (Lyc.)	10-04791	---
EGT Thermocouple 8mm, Bayonet (Rotax)	10-00967	---

FUEL AIRBOX PRESSURE

Description	Part No.	Price
Fuel Airbox Pressure Range: 0-7 Diff.	10-02401	---

FUEL FLOW

Description	Part No.	Price
Fuel Flow 0-8 6PH	10-02403	---
Fuel Flow 0-20 6PH	10-02404	---
Fuel Flow 0-30 6PH	10-02405	---

OIL TEMPERATURE

Description	Part No.	Price
Oil Temp. Gauge 100-300°F	10-00047	---
1-1/4 inch VDO - TSO'd Electronic Temperature Gauges 100-300 deg F	10-02779	---
Oil Temp. Probe 3/8-24 (Automotive)	10-00969	---
Oil Temp. Probe 5/8-18 (Lyc./Cont.)	10-00418	---
Oil Temp. Probe 10mm (Rotax 912/914)	10-00973	---

FUEL PRESSURE

Description	Part No.	Price
Fuel Pressure Gauge 15 PSI	10-00048	---
Fuel Pressure Gauge 30 PSI	10-00049	---
Fuel Pressure Gauge 0-80 psi	10-00050	---

VOLTMETER

Description	Part No.	Price
Voltmeter 18-36V	10-00052	---
Voltmeter 9-17V	10-00578	---

FLAP INDICATOR

Description	Part No.	Price
Flap Position Indicator 0-30°	10-00053	---
Flap Position Indicator 0-40°	10-00054	---
Flap Position Indicator up-full	10-00055	---
Flap Indicator Transducer AN5785	AN5785	---

MANIFOLD PRESSURE

Description	Part No.	Price
5-35"	10-02438	---
5-50"	10-02439	---

For Experimental aircraft only. See next page for TSO'd Gauges. Mount individually or as a cluster.

MOUNTING INFORMATION

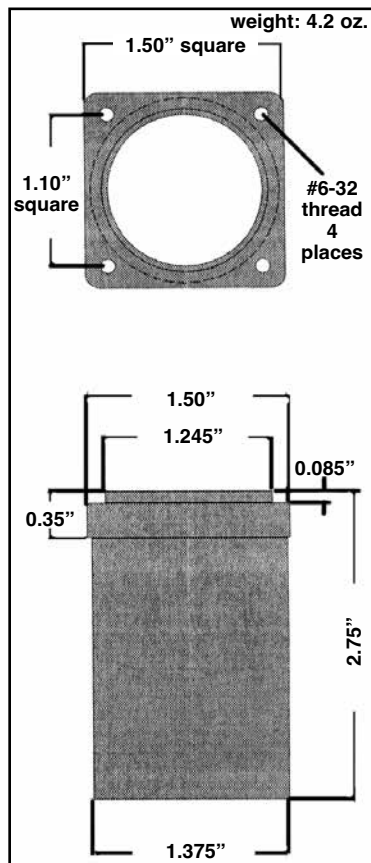

IN